

UPJ-1P Compact VariO™ Loudspeaker



***Keep these important operating instructions.
Check www.meyersound.com for updates.***

DECLARATION OF CONFORMITY ACCORDING TO ISO/IEC GUIDE 22 AND EN 45014

Manufacturer's Name:

Meyer Sound Laboratories Inc.

Manufacturer's Address:

2832 San Pablo Avenue
Berkeley, CA 94702-2204, USA

Declares that the products

Product Name: UPJ-1P

Product Options: All

Conforms to the following Product Specifications

Safety: IEC 60065:1998

EN 60065:1998

UL 6500/09.99

CAN/CSA E60065-00

EMC: EN 55103-1: 1997 emission(1)

EN 55103-2: 1997 immunity(2)

This device complies with the requirements of the Low Voltage Directive 73 / 23 / EEC and the EMC Directive 89 / 336 / EEC.

This device also complies with EN 55103-1 & -2. Operation is subject to the following two conditions:

- (1) this device may not cause harmful interference, and
- (2) this device must accept any interference received, including interference that may cause undesired operation.

Note: Installation restrictions may be applied by supply authorities in relation to harmonics and voltage fluctuations (flicker).

Supplementary Information

The product herewith complies with the requirements of the Low Voltage Directive 73/23/EEC and the EMC Directive 89/336/EEC.

Office of Quality Manager
Berkeley, California USA
August 28, 2003

European Contact: Your local Meyer Sound dealer or Meyer Sound Germany, GmbH. Carl Zeiss Strasse 13, 56751 Polch, Germany.
Telephone: 49.2654.9600.58 Fax: 49.2654.9600.59

Environmental specifications for Meyer Sound Electronics products

Operating Temperature	0° C to + 45° C
Non operating Temperature	<-40° C or > +75° C
Humidity	to 95% at 35° C
Operating Altitude	to 4600 m (15,000 ft)
Non operating Altitude	to 6300 m (25,000 ft)
Shock	30 g 11 msec half-sine on each of 6 sides
Vibration	10 Hz to 55 Hz (0.010 m peak-to-peak excursion)



COPYRIGHT

© 2003 Meyer Sound. All rights reserved.

UPJ-1P Compact VariO Loudspeaker Operating Instructions

The contents of this manual are furnished for informational purposes only, are subject to change without notice, and should not be construed as a commitment by Meyer Sound Laboratories Inc. Meyer Sound assumes no responsibility or liability for any errors or inaccuracies that may appear in this manual. Except as permitted by applicable copyright law, no part of this publication may be reproduced, stored in a retrieval system, or transmitted, in any form or by any means, electronic, mechanical, recording or otherwise, without prior written permission from Meyer Sound.





UltraSeries, VariO, Intelligent AC, RMS and all alpha-numeric designations for Meyer Sound products and accessories are trademarks of Meyer Sound. Meyer Sound, Meyer Sound MAPP Online, SIM and QuickFly are registered trademarks of Meyer Sound Laboratories Inc. (Reg. U.S. Pat. & Tm. Off.). All third-party trademarks mentioned herein are the property of their respective trademark holders.

Printed in the U.S.A.

Part Number: 05.134.400.01, Rev. B

SYMBOLS USED

These symbols indicate important safety or operating features in this booklet and on the chassis:

			
Dangerous voltages: risk of electric shock	Important operating instructions	Frame or chassis	Protective earth ground
Pour indiquer les risques résultant de tensions dangereuses	Pour indiquer important instructions	Masse, châssis	Terre de protection
Zu die gefahren von gefährliche spanning zeigen	Zu wichtige betriebsanweisung und unterhaltsanweisung zeigen	Rahmen oder chassis	Die schutzerde
Para indicar voltajes peligrosos.	Instrucciones importantes de funcionamiento y/o mantenimiento	Armadura o chassis	Tierra proteccionista

IMPORTANT SAFETY INSTRUCTIONS

1. Read these instructions.
 2. Keep these instructions.
 3. Heed all warnings.
 4. Follow all instructions.
 5. Do not use this loudspeaker near water.
 6. Clean only with dry cloth.
 7. Do not block any ventilation openings. Install in accordance with Meyer Sound's installation instructions.
 8. Do not install near any heat sources such as radiators, heat registers, stoves, or other apparatus that produce heat.
 9. Do not defeat the safety purpose of the grounding-type plug. A grounding type plug has two blades and a third grounding prong. The third prong is provided for your safety. If the provided plug does not fit into your outlet, consult an electrician for replacement of the obsolete outlet.
 10. Protect the power cord from being walked on or pinched, particularly at plugs, convenience receptacles, and the point where they exit from the loudspeaker. The AC mains plug or appliance coupler shall remain readily accessible for operation.
 11. Only use attachments/accessories specified by Meyer Sound.
 12. Use only with the caster rails or rigging specified by Meyer Sound, or sold with the loudspeaker. Handles are for carrying only.
-
- 

CAUTION: Rigging should only be done by experienced professionals.
-
13. Unplug this loudspeaker during lightning storms or when unused for long periods of time.
 14. Refer all servicing to qualified service personnel. Servicing is required when the loudspeaker has been damaged in any way, such as when the power-supply cord or plug has been damaged; liquid has been spilled or objects have fallen into the loudspeaker; rain or moisture has entered the loudspeaker; the loudspeaker has been dropped; or when for undetermined reasons the loudspeaker does not operate normally.

SAFETY SUMMARY

English

- To reduce the risk of electric shock, disconnect the loudspeaker from the AC mains before installing audio cable. Reconnect the power cord only after making all signal connections.
- Connect the loudspeaker to a two-pole, three-wire grounding mains receptacle. The receptacle must be connected to a fuse or circuit breaker. Connection to any other type of receptacle poses a shock hazard and may violate local electrical codes.
- Do not install the loudspeaker in wet or humid locations without using weather protection equipment from Meyer Sound.
- Do not allow water or any foreign object to get inside the loudspeaker. Do not put objects containing liquid on or near the unit.
- To reduce the risk of overheating the loudspeaker, avoid exposing it to direct sunlight. Do not install the unit near heat-emitting appliances, such as a room heater or stove.
- This loudspeaker contains potentially hazardous voltages. Do not attempt to disassemble the unit. The unit contains no user-serviceable parts. Repairs should be performed only by factory-trained service personnel.

Français

- Pour réduire le risque d'électrocution, débrancher la prise principale de l'haut-parleur, avant d'installer le câble d'interface allant à l'audio. Ne rebrancher le bloc d'alimentation qu'après avoir effectué toutes les connections.
- Branchez l'haut-parleur dans une prise de courant à 3 dérivations (deux pôles et la terre). Cette prise doit être munie d'une protection adéquate (fusible ou coupe-circuit). Le branchement dans tout autre genre de prise pourrait entraîner un risque d'électrocution et peut constituer une infraction à la réglementation locale concernant les installations électriques.
- Ne pas installer l'haut-parleur dans un endroit où il y a de l'eau ou une humidité excessive.

- Ne pas laisser de l'eau ou tout objet pénétrer dans l'haut-parleur. Ne pas placer de récipients contenant un liquide sur cet appareil, ni à proximité de celui-ci.
- Pour éviter une surchauffe de l'haut-parleur, conserver-la à l'abri du soleil. Ne pas installer à proximité d'appareils dégageant de la chaleur tels que radiateurs ou appareils de chauffage.
- Ce haut-parleur contient des circuits haute tension présentant un danger. Ne jamais essayer de le démonter. Il n'y a aucun composant qui puisse être réparé par l'utilisateur. Toutes les réparations doivent être effectuées par du personnel qualifié et agréé par le constructeur.

Deutsch

- Um die Gefahr eines elektrischen Schlages auf ein Minimum zu reduzieren, den Lautsprecher vom Stromnetz trennen, bevor ggf. ein Audio-Schnittstellensignalkabel angeschlossen wird. Das Netzkabel erst nach Herstellung aller Signalverbindungen wieder einstecken.
- Der Lautsprecher an eine geerdete zweipolige Dreiphasen-Netzsteckdose anschließen. Die Steckdose muß mit einem geeigneten Abzweigschutz (Sicherung oder Leistungsschalter) verbunden sein. Der Anschluß der unterbrechungsfreien Stromversorgung an einen anderen Steckdosentyp kann zu Stromschlägen führen und gegen die örtlichen Vorschriften verstoßen.
- Der Lautsprecher nicht an einem Ort aufstellen, an dem sie mit Wasser oder übermäßig hoher Luftfeuchtigkeit in Berührung kommen könnte.
- Darauf achten, daß weder Wasser noch Fremdkörper in das Innere den Lautsprecher eindringen. Keine Objekte, die Flüssigkeit enthalten, auf oder neben die unterbrechungsfreie Stromversorgung stellen.
- Um ein Überhitzen dem Lautsprecher zu verhindern, das Gerät vor direkter Sonneneinstrahlung fernhalten und nicht in der Nähe von wärmeabstrahlenden

Haushaltsgeräten (z.B. Heizgerät oder Herd) aufstellen.

- Im Inneren diesem Lautsprecher herrschen potentiell gefährliche Spannungen. Nicht versuchen, das Gerät zu öffnen. Es enthält keine vom Benutzer reparierbaren Teile. Reparaturen dürfen nur von ausgebildetem Kundendienstpersonal durchgeführt werden.

Español

- Para reducir el riesgo de descarga eléctrica, desconecte de la red de voltaje el altoparlante antes de instalar el cable de señal de audio. Vuelva a conectar la alimentación de voltaje una vez efectuadas todas las interconexiones de señalización de audio.
- Conecte el altoparlante a un tomacorriente bipolar y trifilar con neutro de puesta a tierra. El tomacorriente debe estar conectado a la protección de derivación apropiada (ya sea un fusible o un disyuntor). La conexión a cualquier otro tipo de tomacorriente puede constituir peligro de descarga eléctrica y violar los códigos eléctricos locales.
- No instale el altoparlante en lugares donde haya agua o humedad excesiva.
- No deje que en el altoparlante entre agua ni ningún objeto extraño. No ponga objetos con líquidos encima de la unidad ni cerca de ella.
- Para reducir el riesgo de sobrecalentamiento, no exponga la unidad a los rayos directos del sol ni la instale cerca de artefactos que emiten calor, como estufas o cocinas.
- Este altoparlante contiene niveles de voltaje peligrosos en potencia. No intente desarmar la unidad, pues no contiene piezas que puedan ser reparadas por el usuario. Las reparaciones deben efectuarse únicamente por parte del personal de mantenimiento capacitado en la fábrica.

CONTENTS

INTRODUCTION	1
How to Use this Manual	1
Introducing the UPJ-1P Compact VariO™ Loudspeaker	1
CHAPTER 1: Power Requirements	3
AC Power	3
Voltage Requirements	3
Current Requirements	4
Power Connector Wiring	4
Electrical Safety Issues	4
CHAPTER 2: Amplification and Audio	5
Audio Input	5
Looping Audio Input Module	5
Looping, Polarity, and Attenuating Audio Input Module	5
Amplification and Limiting	6
Amplifier Cooling System	6
CHAPTER 3: RMS™ Remote Monitoring System (Optional)	7
Understanding the User Panel	7
Service LED (Red)	8
Service Button	8
Wink LED (green)	8
Reset Button	8
Activity LED (Green)	8
User Interface	8
Daisy-Chained	9
CHAPTER 4: Using Subwoofers with the UPJ-1P	9
Adding a Line Driver	9
Engaging the Lo-Cut filter	10
Digital Signal Processors	10
CHAPTER 5: System Design and Integration	11
Meyer Sound MAPP Online®	11
SIM® Measurement System	12
Source Independent Measurement Technique	12
Applications	12
CHAPTER 6: Rotating the VariO Horn	13
CHAPTER 7: QuickFly Rigging	15
Basic Rigging Configurations	15
Pole-Mounting the UPJ-1P, Single Unit	16
Using the MLB-UPJ L-Bracket	16
Wall Mount	16
Ceiling Mount	16
Floor Mount	17

MYA-UPJ Mounting Yoke Assembly	17
Using the MAA-UPJ Array Adapter	17
Horizontal Array	18
<i>Pole-Mounting a Horizontal Array</i>	18
<i>Flying a Horizontal Array</i>	18
Vertical Array	18
<i>Ceiling Mounting a Vertical Array</i>	19
<i>Flying a Vertical Array</i>	19
Appendix A	21
Basic Troubleshooting	21
Appendix B	23
UPJ-1P Specifications	23

INTRODUCTION

HOW TO USE THIS MANUAL

As you read this manual, you'll find figures and diagrams to help you understand and visualize what you're reading. You'll also find numerous icons that serve as cues to flag important information or warn you against improper or potentially harmful activities. These icons include:



A **NOTE** identifies an important or useful piece of information relating to the topic under discussion.



A **TIP** offers a helpful tip relevant to the topic at hand.



A **CAUTION** gives notice that an action can have serious consequences and could cause harm to equipment or personnel, delays, or other problems.

INTRODUCING THE UPJ-1P COMPACT VARIO™ LOUDSPEAKER

The UPJ-1P compact VariO loudspeaker combines the advantages of being self-powered with the placement and arraying flexibility afforded by a VariO rotatable horn. Remarkably compact and lightweight, the UPJ-1P (Figure i.1) produces a robust peak power output of 128 dB SPL at 1 meter, making it suitable for use either as a primary loudspeaker in small rooms or as a fill, delay, effects or under-balcony loudspeaker in any type of large or distributed system application.



Figure i.1: UPJ-1P compact VariO loudspeaker

The UPJ-1P's low-frequency section employs a 10-inch neodymium magnet cone driver, while the high-frequency section utilizes a 0.75-inch exit, 3-inch diaphragm compression driver of proprietary design. The VariO horn allows quick rotation to provide a 80° x 50° coverage pattern in either the horizontal or the vertical plane. A two-channel class AB power amplifier with complementary MOSFET output stages provides a total output of 300 watts for the low- and high-frequency sections.

The UPJ-1P cabinet's end plates provide unprecedented mounting, flying and arraying flexibility, and are made of heavy duty, high-strength, corrosion-resistant 6061-T6 aluminum. Strategically placed M8 threaded points allow simple mounting using eyebolts or directly to third party pole assemblies. Available QuickFly® rigging options — including an array adapter (also made from 6061-T6 aluminum), yokes, and “L”-brackets — attach easily and securely to the aluminum end plates allowing UPJ-1P to be mounted or flown, either as a single cabinet or in arrays. The optional RMS™ remote monitoring system module allows comprehensive monitoring of all key system parameters on a remote RMS host PC.



NOTE: Read this entire manual carefully before configuring and deploying a UPJ-1P system. In particular, pay careful attention to the sections about safety issues.

Information and specifications are applicable as of the date of this printing. Updates and supplementary information are posted on the Meyer Sound website at:

<http://www.meyersound.com>

You may contact Meyer Sound Technical Support at:

Tel: +1 510 486.1166

Fax: +1 510 486.8356

Email: techsupport@meyersound.com

CHAPTER 1: POWER REQUIREMENTS

Self-powered and compact, the UPJ-1P combines advanced loudspeaker technology with equally advanced power capabilities. Understanding power distribution, voltage and current requirements, as well as electrical safety issues, is critical to the safe operation of the UPJ-1P.

AC POWER

The UPJ-1P uses a PowerCon 3-pole AC mains system with locking connectors to prevent accidental disconnection. It may also be daisy-chained by using the grey connector (Figure 1.1) to loop units together. The blue connector serves as the power input; to loop additional units, simply attach a cable from the grey connector of the first loudspeaker to the blue connector of the second, and so on. One looping connector is included with each UPJ-1P. Optional assembled looping cables can be purchased from Meyer Sound.

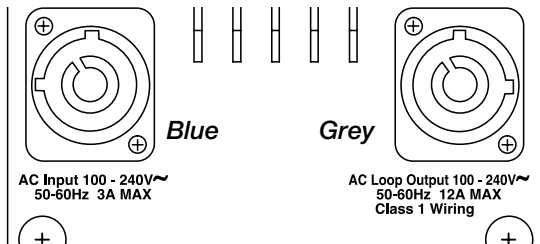

Figure 1.1. You can daisy-chain UPJ-1P loudspeakers using the grey connector.

CAUTION: Do not loop more than four UPJ-1Ps from the loop out connector when connected at 115 V and not more than eight when driven at 230 V.

CAUTION: Be sure to select the correct power plug for the AC power in the area in which you operate your UPJ-1P loudspeaker.

When AC power is applied to the UPJ-1P, its Intelligent AC™ power supply automatically selects the correct operating voltage, allowing it to be used internationally without manually setting voltage switches. Intelligent AC performs the following protective functions to compensate for hostile conditions on the AC mains:

- Suppresses high-voltage transients up to several kilovolts
- Filters common mode and differential mode radio frequencies (EMI)
- Sustains operation temporarily during low-voltage periods

The UPJ-1P can withstand continuous voltages up to 264 V and allows any combination of voltage to GND (that is, neutral-line-ground or line-line-ground).

CAUTION: Continuous voltages higher than 264 V may damage your UPJ-1P.

Voltage Requirements

The UPJ-1P operates safely and without audio discontinuity if the AC voltage stays within the operating window of 90-264 V AC, at 50 or 60 Hz.

After applying AC power, the system is muted while the circuitry charges up and stabilizes. During the next two seconds the following events occur:

1. The fan turns on.
2. The main power supply slowly ramps on.
3. The green On/Temp LED on the user panel lights up, indicating that the system is enabled and ready to pass audio signals.

CAUTION: If the On/Temp LED does not illuminate or the system does not respond to audio input after ten seconds, remove AC power immediately. Verify that the voltage is within the proper range. If the problem persists, please contact Meyer Sound or an authorized service center.

If the voltage drops below the low boundary of its safe operating range (brownout), the UPJ-1P loudspeaker uses stored energy to continue functioning briefly, and shuts down only if voltage does not rise above the low boundary before storage circuits are depleted. How long the loudspeaker will continue to function during brownout depends on the amount of voltage drop and the audio source level during the drop.

If the voltage increases above the upper boundary of the range, the power supply can be damaged.

NOTE: It is recommended that the supply be operated in its rated voltage window at least a few volts away from the extreme points. This ensures that AC voltage variations from the service entry – or peak voltage drops due to cable runs – do not cause the amplifier to cycle on and off or cause damage to the power supply.

Current Requirements

Each UPJ-1P requires approximately 3 A rms max at 115 V AC for proper operation. This allows up to five UPJ-1Ps to be powered from one 15 A breaker at 115 V and up to 9 loudspeakers at 230 V.

The UPJ-1P presents a dynamic load to the AC mains, which causes the amount of current to fluctuate between quiet and loud operating levels. Since different cables and circuit breakers heat up at varying rates, it is essential to understand the types of current ratings and how they correspond to circuit breaker and cable specifications.

The *maximum long-term continuous current* is the maximum rms current during a period of at least ten seconds. It is used to calculate the temperature increase in cables, in order to select a cable size and gauge that conforms to electrical code standards. It is also used to select the rating for slow-reacting thermal breakers.

The *burst current* is the maximum rms current during a period of approximately one second, used to select the rating of most magnetic breakers and to calculate the peak voltage drop in long AC cables according to the formula:

$$V \text{ pk (drop)} = I \text{ pk} \times R \text{ (cable total)}$$

The *ultimate short-term peak current* is used to select the rating of fast reacting magnetic breakers.

Use Table 1.1 below as a guide when selecting cable gauge size and circuit breaker ratings for your operating voltage.

Table 1.1: UPJ-1P Current Ratings

Current Draw	115 V AC	230 V AC	100 V AC
Max. long-term continuous	3.2 A rms	1.65 A rms	3.7 A rms
Burst current	5 A rms	2.5 A rms	5.8 A rms
Ultimate short-term peak	17 A pk	8.5 A pk	20 A pk
Idle current	0.41 A rms	0.33 A rms	0.42 A rms



NOTE: For best performance, the AC cable voltage drop should not exceed 10 volts, or 10 percent at 115 volts and 5 percent at 230 volts. Make sure that even with the AC voltage drop, the AC voltage always stays within the operating ranges.

The minimum electrical service amperage required by a UPJ-1P system is the sum of each loudspeaker's maximum continuous rms current. An additional 30 percent above the minimum amperage is recommended to prevent peak voltage drops at the service entry.

Power Connector Wiring

The UPJ-1P loudspeaker requires a grounded outlet. It is very important that the system be properly grounded in order to operate safely and properly. Use the AC cable wiring diagram in Figure 1.2 to create international or special-purpose power connectors:

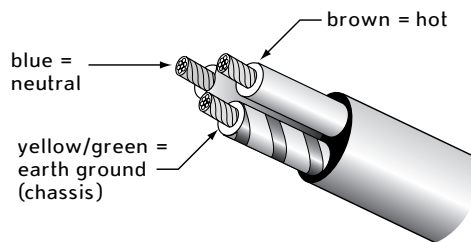

Figure 1.2. AC cable color code

If the colors referred to in the diagram don't correspond to the terminals in your plug, use the following guidelines:

- Connect the blue wire to the terminal marked with an N or colored black.
- Connect the brown wire to the terminal marked with an L or colored red.
- Connect the green and yellow wire to the terminal marked with an E or colored green or green and yellow.

ELECTRICAL SAFETY ISSUES



CAUTION: The UPJ-1P requires a ground connection. Always use a grounded outlet and plug.

CHAPTER 2: AMPLIFICATION AND AUDIO

The UPJ-1P uses sophisticated amplification and protection circuitry to produce consistent and predictable results in any system design. This chapter will help you understand and harness the power of the UPJ-1P amplifier and audio systems.

The rear panel of the UPJ-1P (Figure 2.1) provides two slots for processor modules. The top slot contains the audio input/control module. The optional RMS™ communications module sits in the bottom slot if installed; a blank plate covers the bottom slot if RMS is not installed.

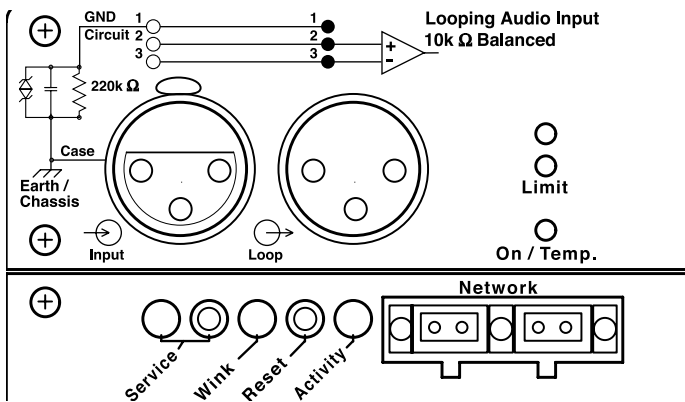

Figure 2.1. The rear panel of the UPJ-1P with looping audio input module and optional RMS



NOTE: See Chapter 3, “RMS Remote Monitoring System (Optional)” for more information on using RMS with the UPJ-1P.

AUDIO INPUT

The UPJ-1P uses a balanced, female XLR connector for the audio input module in the UPJ-1P, and a male XLR loop connector to interconnect multiple UPJ-1Ps. The loop connector, wired in parallel to the audio input, transmits the input signal if the UPJ-1P is turned off for any reason.

The UPJ-1P audio input presents a 10 kOhm balanced input impedance to a three-pin XLR connector with the following connectors:

- Pin 1 — 220 kOhm to chassis and earth ground (ESD clamped)
- Pin 2 — Signal (+)
- Pin 3 — Signal (-)
- Case — Earth (AC) ground and chassis

There are two interchangeable audio input modules with and without controls for different applications.



CAUTION: Shorting an input connector pin to the case can form a ground loop and cause hum.

Looping Audio Input Module

If the UPJ-1P is equipped with the looping audio input module (Figure 2.2), Pins 2 and 3 carry the input as a differential signal; pin 2 is hot relative to pin 3, resulting in a positive pressure wave when a positive signal is applied to pin 2.

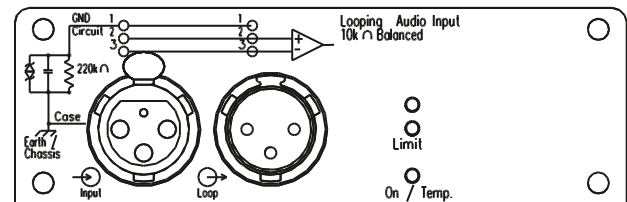

Figure 2.2. The looping audio input module

Pin 1 is connected to earth through 220-kOhm, 1000 pF, 15 V clamp network. This ingenious circuit provides virtual ground lift at audio frequencies, while allowing unwanted signals to bleed to ground. Use standard audio cables with XLR connectors for balanced signal sources with all 3 pins connected on both ends. Telescopic grounding is not recommended.

Looping, Polarity, and Attenuating Audio Input Module

This looping, polarity, and attenuating audio input module (Figure 2.3) has a balanced, female XLR audio input connector, a male XLR loop connector, an input polarity switch, and a level attenuator. The input polarity switch offers a convenient method of reversing the polarity of the loudspeaker system.

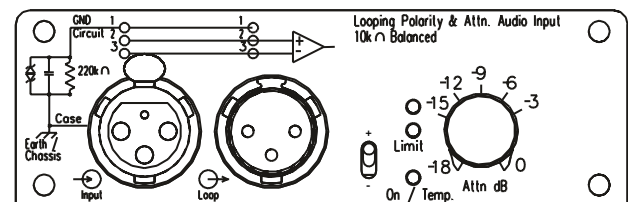

Figure 2.3. The looping, polarity, and attenuating audio input module

When the input polarity switch is in the up (+) position, pin 2 is hot. When the switch is down (-), pin 3 is hot relative to pin 2, resulting in a positive pressure wave when a positive signal is applied to pin 3. The level attenuator operates between 0 dB (no level attenuation) when turned all the way to the right, to -18 dB when turned all the way to the left.

Regardless of the input module type, audio signals can be daisy-chained using the loop output connector on the user panel. A single source can drive multiple UPJ-1Ps with a paralleled input loop, creating an unbuffered hard-wired loop connection.

If driving multiple UPJ-1Ps in a system, make certain that the source device can drive the total load impedance presented by the paralleled input circuit of the array. The audio source must be capable of producing a minimum of 20 dB volts (10 volts rms into 600 ohms) to produce the maximum peak SPL over the operating bandwidth of the loudspeaker.

To avoid distortion from the source, make sure the source equipment provides an adequate drive circuit design for the total paralleled load impedance presented by the system. The input impedance for a single loudspeaker is 10 kOhms. If n represents the number of UPJ-1P loudspeakers in a system, paralleling the inputs of n loudspeakers will produce a balanced input load of 10 kOhms divided by n .



NOTE: Most source equipment is safe for driving loads no smaller than 10 times the source's output impedance.

For example, cascading an array of 10 units consisting of UPJ-1Ps produces an input impedance of 1000 ohms (10 kOhms divided by 10). The source equipment should have an output impedance of 100 ohms or less. This is also true when connecting UPJ-1Ps in parallel (loop out) with other self-powered Meyer Sound loudspeakers and subwoofers



TIP: If noises such as hiss and popping are produced by the loudspeaker, disconnect the audio cable from the loudspeaker. If the noise stops, then most likely the problem is not with the loudspeaker. Check the audio cable, source, and AC power for the source of the problem.



NOTE: Ensure that all cabling carrying signal to multiple UPJ-1Ps is wired correctly (Pin 1 to Pin 1, Pin 2 to Pin 2, and so on), to prevent the polarity from being reversed. If one or more loudspeakers in a system has reversed polarity, this can cause severe degradation in frequency response and coverage.

AMPLIFICATION AND LIMITING

The low- and high-frequency drivers in the UPJ-1P are powered by a two-channel proprietary Meyer Sound amplifier utilizing complementary MOSFET output stages. The amplifier processes the audio through the use of electronic crossover, phase and frequency response correction filters as well as driver protection circuitry. Each channel

has peak and rms limiters that prevent driver over-excitation and regulate the temperature of the voice coil. Limiter activity for the high and low channels is indicated by two yellow limit LEDs on the rear panel (the high-frequency limit LED is on top and the low-frequency limit LED is on bottom).

The UPJ-1P performs within its acoustical specifications and operates at a normal temperature if the limit LEDs are on for no longer than two seconds, and off for at least one second. If either LED remains on for longer than three seconds, that channel incurs these consequences:

- Increasing the input level will not increase the volume.
- The system distorts due to clipping and nonlinear driver operation.
- Unequal limiting between the low and high frequency drivers alters the frequency response.

Limiters protect the system under overload conditions and exhibit smooth sonic characteristics, but we recommend that you do not drive the UPJ-1P into continuous limiting.



NOTE: Limit LEDs indicate when the safe power level is exceeded. If a UPJ-1P system begins to limit before reaching the required SPL, consider adding more loudspeakers.

AMPLIFIER COOLING SYSTEM

The UPJ-1P amplifier employs a combination of natural convection and forced air in its cooling system. The large heatsink used in the amplifier allows natural convection cooling from air flowing over the fins. A low noise fan forces air to the fins, keeping the temperature on the amplifier low even when the loudspeakers are being used at high ambient temperature, in tightly packed conditions and/or at high continuous levels.



CAUTION: To keep the heatsink from getting too hot, ensure proper ventilation around the loudspeaker, especially when using the UPJ-1P in tightly packed conditions.

If the temperature of the heatsink reaches 75° C (167° F), the fan switches to high speed and the On/Temp. LED on the rear panel turns from green (On) to red (Temp.) The unit continues to operate normally even if On/Temp LED is red.

When the heatsink temperature decreases to 65° C (149° F), the On/Temp. LED changes from red to green



CAUTION: The heatsink can reach temperatures up to 75° C (167° F) during normal operation. Use extreme caution when approaching the rear of the cabinet.

CHAPTER 3: RMS REMOTE MONITORING SYSTEM (OPTIONAL)

An optional RMS communication module can be installed in the UPJ-1P's amplifier to make use of Meyer Sound's RMS remote monitoring system.

RMS is a real-time networked monitoring system that connects Meyer Sound self-powered loudspeakers with a Windows-based PC at the sound mix position or other desired location. Optional RMS software delivers extensive status and system performance data directly to you from every installed loudspeaker.

RMS allows you to monitor amplifier voltages, limiting activity, power output, temperature, fan and driver status, warning alerts, and other key data for up to 62 loudspeakers without a network repeater; data is updated two to five times per second.



NOTE: Optional Loudspeaker Mute and Solo functions, helpful for acoustic setup or troubleshooting, are also available. A jumper must be installed in the RMS communication module in order to enable Mute and/or Solo functionality; the software also needs to be enabled for these functions.

If the UPJ-1P is shipped fitted with an RMS communication module, the loudspeaker is shipped with these functions disabled. Once enabled, the jumper(s) can still be removed to eliminate any chance of an operator error (a muting error, for example) during a performance, and both functions can be controlled by software commands in any case. Also note that RMS does not control loudspeaker volume or AC power.

Loudspeakers are identified on the network by Node Names assigned during a one-time "commission" (Figure 3.1) into the RMS database that resides on your computer (as a part of the software).

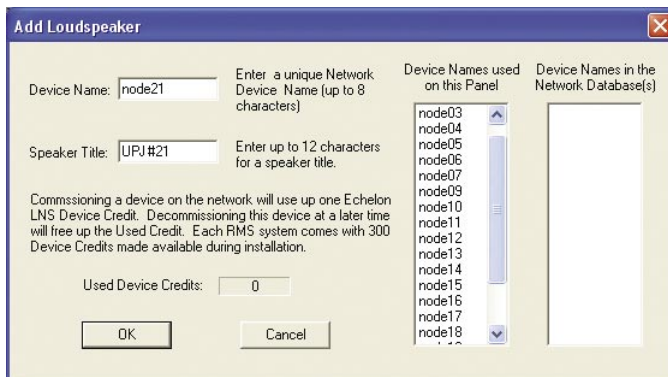

Figure 3.1. Commissioning a loudspeaker using RMS

This information is permanently retained on each RMS communication board and in the computer RMS database unless you modify it. Speaker View labels can be modified at any time, allowing you to customize how you view the data. In addition, any UPJ-1P can be physically identified from RMS software by activating the Wink function – a Wink LED will turn on the RMS communication board that corresponds to its Node Name.

A UPJ-1P is identified using the RMS software by activating the "service" function; an icon will show up on the RMS screen corresponding to its Node Name (Figure 3.2). This makes verifying Speaker View titles and speaker field labels easy, using the Wink or Service Button commands.

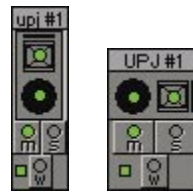

Figure 3.2. RMS loudspeaker icons



NOTE: If the UPJ-1P's amplifier heatsink temperature exceeds 75° C (167° F), the RMS user panel On/Temp LED will turn red, while the loudspeaker icon in the RMS host software will respond by displaying yellow – indicating that the UPJ-1P is running hot, but still within safe operating limits. If the color in the RMS host software changes to red, then the UPJ-1P is operating above its 100° C (212° F) maximum safe operating temperature. Check to ensure that the UPJ-1P is properly ventilated and/or decrease the loudspeaker's audio output signal immediately.

UNDERSTANDING THE RMS COMMUNICATION MODULE'S USER PANEL

The RMS user panel is shown in Figure 3.3.

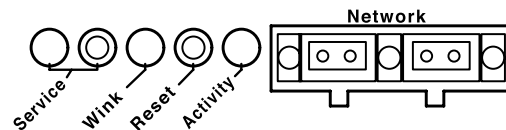

Figure 3.3. The RMS user panel

The RMS user panel has three LEDs and two buttons. The following sections describe their functions.

Service LED (Red)

When blinking once every two seconds, the Service LED indicates that the network hardware is operational, but the loudspeaker is not installed (commissioned) on the network. When a loudspeaker has been installed on the network the, Service LED will be unlit and the Activity LED will flash continuously.



NOTE: When continuously lit, the Service LED indicates that the loudspeaker has had a local RMS hardware failure. In this case, the RMS communication module may be damaged and you should contact Meyer Sound Technical support.

Service Button

Pressing the Service button will notify the corresponding loudspeaker display icon on the RMS screen. When used in combination with the Reset button, the card will be decommissioned from the network and the red Service LED will blink.

Wink LED (green)

When lit, the Wink LED indicates that an ID signal has been sent from the host station computer to the loudspeaker. This is accomplished using the Wink button on the loudspeaker Icon, Meter or Text views in the RMS monitoring program.

Reset Button

Pressing the Reset button will cause the firmware code within the RMS card to reboot. However, the commissioning state of the card will not change (this is stored in flash memory). When used in combination with the Service Button, the card will be decommissioned from the network and the red Service LED will blink.

Activity LED (Green)

When the loudspeaker has been commissioned, the Activity LED will flash continuously. When the Activity LED is unlit the loudspeaker has not been installed on the network.



NOTE: The LEDs and buttons on the user panel of the RMS communication board shown back in figure 3.3 are used exclusively by RMS, and have no effect on the acoustical and/or electrical activity of the UPJ-1P itself – unless MUTE or SOLO is enabled at the board and from the RMS software.

USER INTERFACE

The RMS software features an intuitive, graphical Windows user interface. As mentioned earlier, each loudspeaker appears on the computer's color monitor as a "view" in the form of a status icon, bar graph meter, or text meter (numerical values), depending on your preferences.

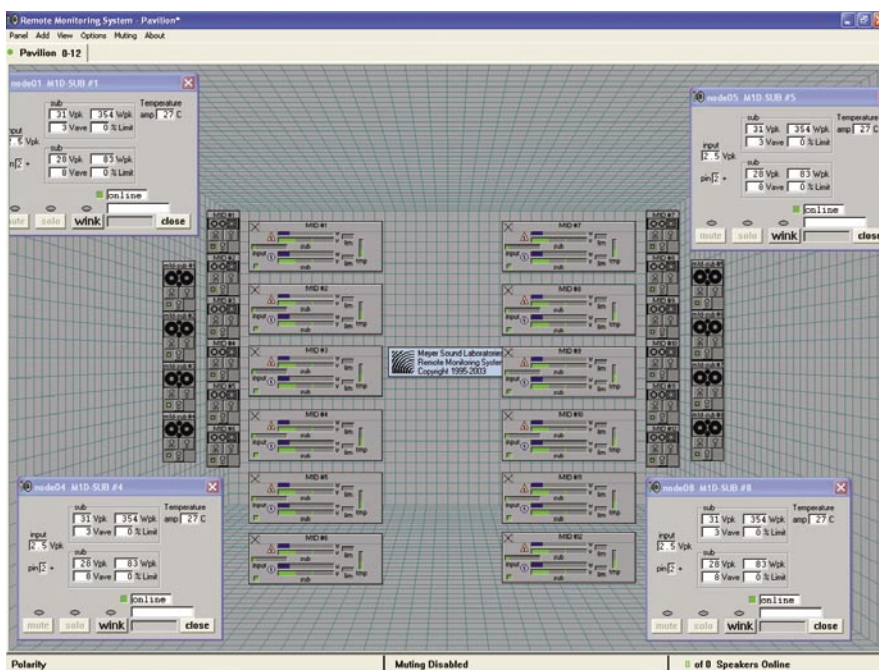

Figure 3.4: Sample RMS display panel

Each view contains loudspeaker identification and data from the unit's amplifier, controller, drivers and power supply. System status conditions cause changes in icon and bar graph indicators, alerting the operator to faults or excessive levels. The views are moveable and are typically arranged on the screen to reflect the physical layout of the loudspeakers. You can design a screen "panel" of icons or meters, as shown in Figure 3.4, and save it on the computer's hard disk, with the panel conveniently named for a unique arrangement or performer.

If the installation pattern changes completely, a new screen panel can be built. If a subset of installed loudspeakers will be used for a subsequent event, only selected loudspeakers need to appear on screen for that performance.

CHAPTER 4: USING SUBWOOFERS WITH THE UPJ-1P

A UPJ-1P loudspeaker system can be deployed in combination with Meyer Sound self-powered USW-1P compact and 650-P high-power subwoofers. These subwoofers can achieve very low frequency response extending system response appreciably and increasing the overall acoustic power of a system in the lowest frequencies. The USW-1P subwoofer extends system frequency response down to 32 Hz, while the 650-P subwoofers extends system frequency response down to 28 Hz.

In addition, the use of high-pass filters to drive a UPJ-1P system with subwoofers flattens overall frequency response and slightly increases UPJ-1P headroom in the lowest end of its usable spectrum.

The ideal ratio of UPJ-1P loudspeakers to subwoofers depends on the configuration of the system, the application, and the frequency content of the signal being reproduced. For most applications, the following ratios yield good results in frequency response and headroom:

- Two UPJ-1P loudspeakers for each USW-1P
- Four UPJ-1P loudspeakers for each 650-P

If two UPJs are used per 650-P, the 650-P should have 6 dB of attenuation for flat frequency response.



NOTE: The limit LEDs indicate when the safe power level is exceeded. If the subwoofers used in the system begin to limit before reaching the required SPL at low frequencies, consider adding more subwoofers to satisfy the SPL requirements without exposing the drivers to excessive heat and/or excursion.

There are three basic connection options for these system configurations.

DAISY-CHAINED

When UPJ-1P loudspeakers and subwoofers are daisy-chained using the loop feature on the user panel, the result will be a fairly flat frequency response. However, the response will show a rise in the 60 to 200 Hz range where the loudspeakers' response overlaps at a ratio of two UPJ-1Ps to each subwoofer.

Make sure the polarity of the UPJ-1Ps and the subwoofers are identical. In a UPJ-1P/USW-1P system, if both the UPJ-1P and the USW-1P are fitted with the standard looping module, there is no polarity switch – both are set to pin 2 +. However, if they are fitted with looping, attenuation

and polarity modules, make sure both are set to the same polarity.

In the case of a UPJ-1P/650-P system, the 650-P employs a polarity switch, so you will need to ensure that the 650-P is set to pin 2 + (same with respect to a UPJ-1P loudspeaker's pin 2 +) when co-planar and in close-proximity to the system.



CAUTION: Make sure that the source equipment can drive the total load of the paralleled system. (See the Audio Input section on page 5.)



NOTE: When a UPJ-1P loudspeaker and a subwoofer are used in their full-range configuration (e.g., looped audio or the same audio feed), their polarities should be kept the same if they are co-planar or near to each other. If they are separated by a greater distance – or delay must be used between them – a measurement system such as Meyer Sound's SIM should be used to determine the correct delay and polarity.

ADDING A LINE DRIVER

Driving a UPJ-1P loudspeaker system and subwoofers with the same signal from different outputs using a line driver allows adjustments to the gain and polarity of each subsystem. This could be used effectively to compensate for the ratio of loudspeakers or acoustical conditions. If gains are adjusted to the same level, the combined response is identical to a daisy-chain configuration with a rise in level in the overlapping range.



NOTE: When driving UPJ-1P loudspeakers from the Mid-Hi output of the LD-1A, LD-2 or LD-3 line driver, with USW-1P or 650-P subwoofers driven from the subwoofer output in their full-range configuration, their polarities should be kept the same if they are co-planar or near each other.

If the UPJ-1P loudspeakers and USW-1P or 650-P subwoofers are separated by a greater distance – or delay must be used between them – a measurement system such as Meyer Sound SIM should be used to determine the correct delay and polarity.

Engaging the Lo-Cut filter

Using the LD-1A, LD-2 or LD-3 Lo-Cut filter (160 Hz position on the LD-3) with a system comprising UPJ-1P loudspeaker and subwoofers in close proximity and co-planar will produce a very flat frequency response with a minimal area of overlap. The UPJ-1P loudspeakers in the system receive their signal following a high-pass filter, while the subwoofers apply their normal internal crossover frequencies to a full range signal. To achieve this flat response, the subwoofers need to have their polarity reversed.



TIP: The flatness of the response is, in any case, dependent on proximity to boundary surfaces.

While the change of polarity with respect to a daisy-chained configuration is needed due to the phase shift caused by the high-pass filter at overlapping frequencies, placing subwoofers more than 4 feet apart from UPJ-1P loudspeakers may require reversing the polarities once again to compensate for the delay propagation.



NOTE: When driving UPJ-1P loudspeakers from the Mid-Hi output of the LD-1A or LD-2 line driver — with the Lo-Cut filter engaged, and 650-P or USW-1P subwoofers in their full-range configuration — their polarities should be reversed if they are co-planar or near each other. The simplest way to achieve this is engaging the “reverse polarity” switch in the sub output of the line driver.

If your UPJ-1P loudspeakers and 650-P or USW-1P subwoofers are separated by a greater distance - or delay must be used between them - a measurement system such as SIM should be used to determine the correct delay and polarity.

delay errors when the DSP is near maximum throughput, which becomes more likely as the number of filters in use in the DSP is using increases.

In no case should a filter higher than 2nd order be used. The additional phase shift introduced deteriorates the impulse response and higher roll-off does not improve crossover interaction. In fact, it is highly recommended that the crossover/filter is set to emulate the low-cut LD-1A/LD-2 and LD-3 (160 Hz position) characteristics themselves, as shown in Table 4.1.

Table 4.1: LD-1/LD-2/LD-3 Lo-Cut Filter Parameters

Type	Order	Pole Frequency	Q
High Pass	2 nd (-12dB/oct)	162 Hz	0.82*

**If the DSP does not have variable Q for high-pass filters, the filter should be set to “Butterworth” (Q = .7).*

If the loudspeakers are going to be driven directly from DSP, verify that the outputs of the processor have the driving capabilities to drive the total load presented by the loudspeakers connected to it.



NOTE: When precise array design, subwoofer integration, DSP and delay systems, and compensation for acoustical conditions all come into play, measurement and correction tools are a must. Meyer Sound’s SIM measurement system and the CP-10 parametric equalizer are both highly recommended.

DIGITAL SIGNAL PROCESSORS

Full-range signals may be applied to Meyer Sound’s self-powered loudspeakers because they have built-in active crossover circuits; external crossovers and digital signal processors (DSP) are optional and should be used very carefully as phase shifts can cause destructive cancellations.

If DSP is used, both UPJ-1P loudspeakers and subwoofers should be fed from the DSP in order to keep their delay time the same. Otherwise you may experience phase shift differences between the UPJ-1P loudspeakers and the subwoofers. In addition, you should verify the delay time between channels: Some DSPs may develop channel-to-channel

CHAPTER 5: SYSTEM DESIGN AND INTEGRATION

Meyer Sound offers two comprehensive tools to assist you with the acoustical and functional requirements of system design and optimization. The chapter introduces you to Meyer Sound MAPP Online® - a powerful online acoustical prediction tool – and SIM®, a robust instrumentation package for system measurement, analysis, and more.

MEYER SOUND MAPP ONLINE

MAPP Online is a powerful, cross-platform, Java-based application for accurately predicting the coverage pattern, frequency response, impulse response, and maximum SPL output of single or arrayed Meyer Sound loudspeakers.

As its name indicates, MAPP Online is an online application: when a prediction is requested, data is sent over the Internet to a high-powered server at Meyer Sound that runs a sophisticated acoustical prediction algorithm using high-resolution, complex (magnitude and phase) polar data. Predicted responses are returned over the Internet and displayed on your computer in color.

With MAPP Online, you can:

- Plan an entire portable or fixed loudspeaker system and determine delay settings for fill loudspeakers.
- Clearly see interactions among loudspeakers and minimize destructive interference.
- Place microphones anywhere in the sound field and predict the frequency response, impulse response, and sound pressure level at the microphone position using MAPP Online's Virtual SIM feature.
- Refine your system design to provide the best coverage of the intended audience area.
- Use a virtual VX-1 program equalizer to predetermine the correct control settings for best system response.
- Gain valuable load information about the array to determine rigging capacities.

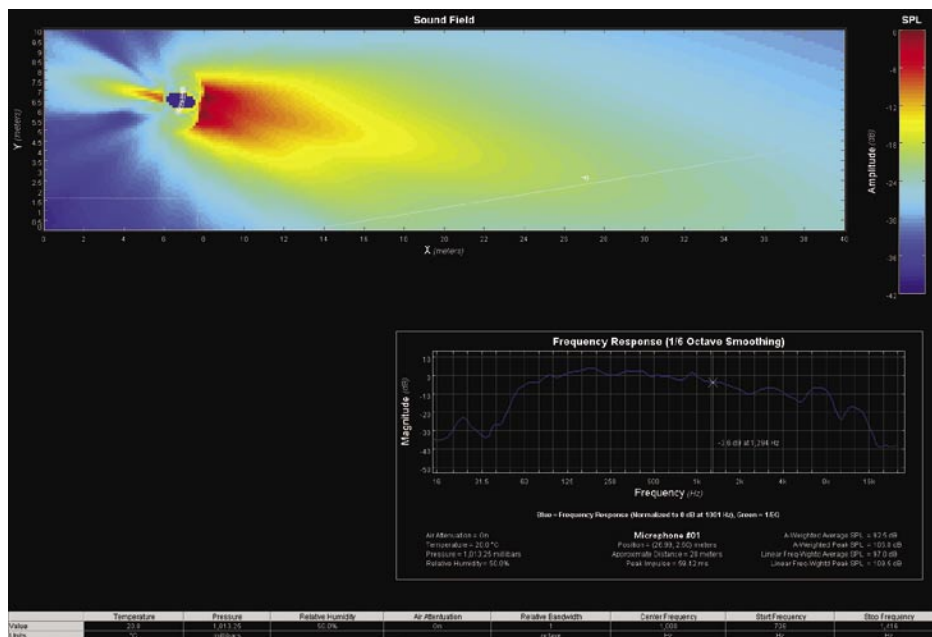

Figure 5.1. MAPP Online is an intuitive, powerful system design tool

Residing on your computer, MAPP Online facilitates configuring arrays of a wide variety of Meyer Sound products and, optionally, defines the environment in which they will operate, including air temperature, pressure, and humidity, as well as the location and composition of walls. You can find MAPP Online at:

www.meyersound.com/products/software/mapponline

requirements “out of the box” – including basic system delay and equalization settings. Its accurate, high-resolution predictions eliminate unexpected onsite adjustments and coverage problems. With MAPP Online, every sound system installation has a maximum chance of success.

MAPP Online is compatible with Windows, Linux, Unix, and Apple Macintosh computers running Mac OS X version 10.1.2 or higher. The MAPP Online Web page above lists additional system requirements and recommendations.



NOTE: In order to use MAPP Online, you will need to register by clicking “Apply for MAPP Online” on the website listed above. After registration and upon approval, an e-mail will be sent to you with a username and password along with the address for the website where you can download MAPP Online. Online instructions will guide you through the download and setup process.

SIM MEASUREMENT SYSTEM

SIM is a measurement and instrumentation system including a selection of hardware and software options, microphones and accessory cables. SIM is optimized for making audio frequency measurements of an acoustical system with a resolution of up to 1/24 of an octave; the high resolution enables you to apply precise electronic corrections to adjust system response using frequency and phase (time) domain information.

Source Independent Measurement Technique

SIM implements the Meyer Sound source independent measurement technique, a dual-channel method that accommodates statistically unpredictable excitation signals. Any excitation signal that encompasses the frequency range of interest (even intermittently) may be used to obtain highly accurate measurements of acoustical or electronic systems. For example, concert halls and loudspeaker systems may be characterized during a musical performance using the program as the test signal, allowing you to:

- View measurement data as amplitude versus time (impulse response) or amplitude and phase versus frequency (frequency response)
- Utilize a single-channel spectrum mode
- View frequency domain data with a logarithmic frequency axis
- Determine and internally compensate for propagation delays using SIM Delay Finder function

Applications

The main application of SIM is loudspeaker system testing and alignment. This includes:

- Measuring propagation delay between the subsystems to set correct polarities and set very precise delay times
- Measuring variations in frequency response caused by the acoustical environment and the placement and interaction of the loudspeakers to set corrective equalization
- Optimizing subwoofer integration
- Optimizing loudspeaker arrays

SIM can also be used in the following applications:

- Microphone calibration and equalization
- Architectural acoustics
- Transducer evaluation and correction
- Echo detection and analysis
- Vibration analysis
- Underwater acoustics

CHAPTER 6: ROTATING THE VARIO HORN

You can easily re-orient the UPJ-1P's VariO rotatable horn to its 80° or 50° configuration and back again. To rotate the UPJ-1P's horn, perform the following steps:

1. Remove the four (4) 10-32 x 5/8" grille cover screws (two from the top and two from the bottom) from the UPJ-1P.
2. Carefully remove the grille.
3. Remove the four (4) 10-32 x 1" horn flange screws.
4. Gently pull the VariO horn from the UPJ-1P cabinet, being careful not to over-stress its wiring.
5. Rotate the horn 90° clockwise to change it from its 80° orientation to 50°. The wider flange around the horn's frame will now be along the sides of the frame instead of the top and bottom (Figure 6.1).
6. Place the horn back into the cabinet. It will fit comfortably snug.
7. Replace the four (4) 10-32 x 1" horn flange screws and the four (4) 10-32 x 5/8" grille cover screws.

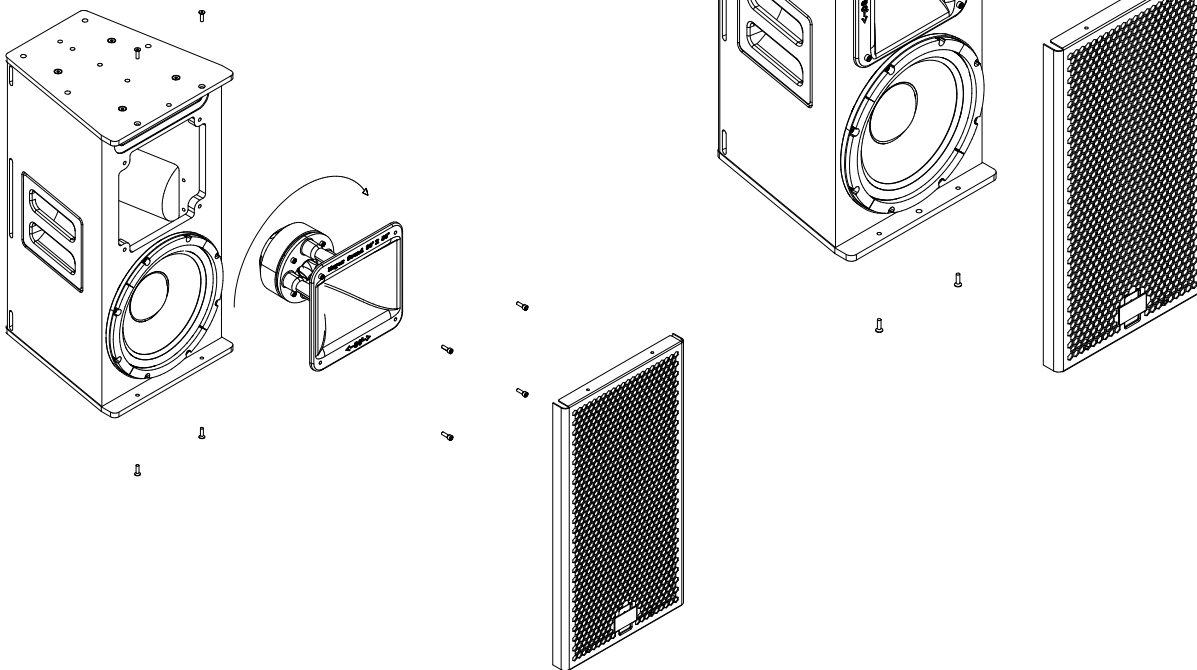

5. Rotate the horn 90° clockwise to change it from its 80° orientation to 50°. The wider flange around the horn's frame will now be along the sides of the frame instead of the top and bottom (Figure 6.1).

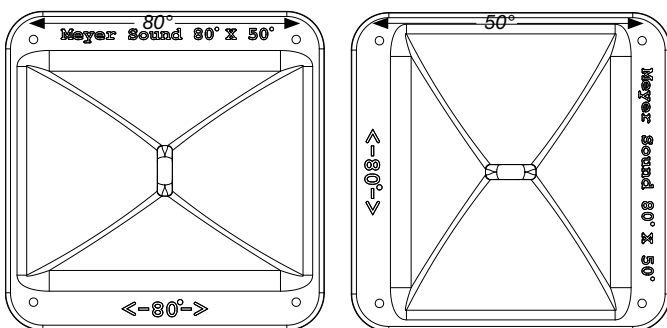

Figure 6.1. The VariO horn at 80° x 50° for wide horizontal coverage (left) and rotated to 50° x 80° for narrow horizontal coverage (right)

CHAPTER 7: QUICKFLY RIGGING

The UPJ-1P features Meyer Sound's QuickFly rigging system with rugged, reliable and deceptively simple components. QuickFly facilitates placing UPJ-1P loudspeakers from single units (hanging or attached to a surface) to constructing rigid, ground-stacked or flown UPJ-1P arrays. The UPJ-1P has integral top and bottom plates made of heavy duty, high-strength, corrosion-resistant 6061-T6 aluminum with threaded metric holes for use with QuickFly rigging and third-party accessories.



NOTE: The threads of the MEP-UPJ end plates are metric for M8 screws.



CAUTION: It is important to inspect rigging hardware regularly and replace worn or damaged components immediately.



CAUTION: All Meyer Sound products must be used in accordance with local, state, federal and industry regulations. It is the owner's and/or user's responsibility to evaluate the reliability of any rigging method for their application. Rigging should be carried out only by experienced professionals.



CAUTION: Always use properly rated rigging hardware.

BASIC RIGGING CONFIGURATIONS

The UPJ-1P ships with two M8 threaded, 20 mm eyebolts (including rubber washers), suitable for hanging the loudspeaker using either a single- or two-hole configuration.

The single-hole configuration is the simplest way to support one UPJ-1P cabinet (Figure 7.1).

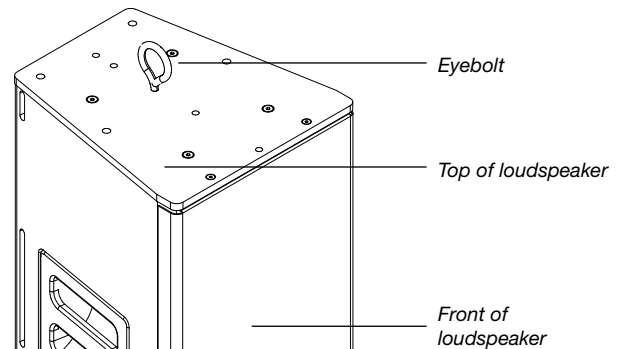

Figure 7.1. Single-hole configuration

The two-hole configuration (Figure 7.2) is recommended over the single point. This configuration provides more safety, stability, and flexibility for aiming and tilting the UPJ-1P for targeted horizontal and vertical coverage.

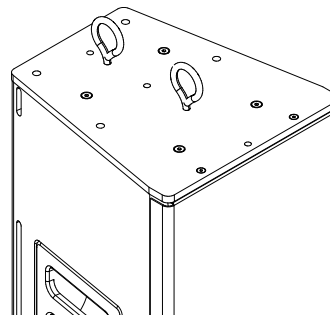

Figure 7.2. Two-hole configuration



CAUTION: Make sure that the eyebolts and bolts are tightened securely. Meyer Sound recommends using Loctite® on the eyebolt threads and/or a safety cable.



CAUTION: Configurations using the UPJ-1P's eyebolt(s) do not support more than two UPJ-1Ps at a 7:1 safety factor.

POLE-MOUNTING THE UPJ-1P, SINGLE UNIT

You can pole-mount the UPJ-1P (Figure 7.3) using a third party pole-mount adapter. The two holes used for attaching eyebolts in a basic double-hole configuration (discussed above) can also be used to attach a pole mount adapter.

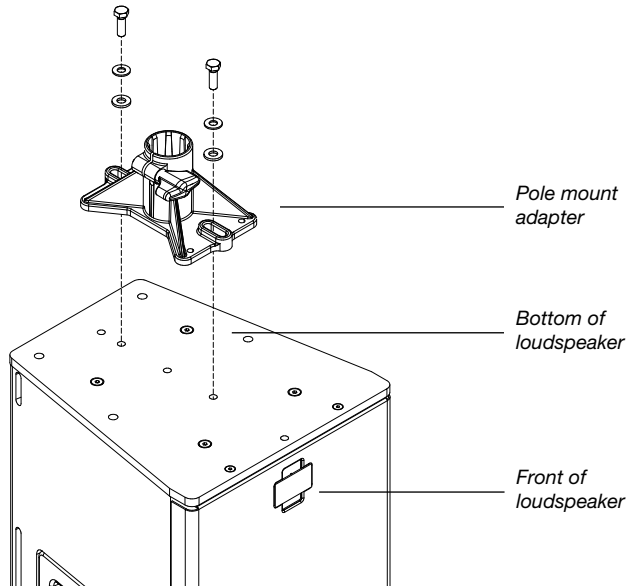

Figure 7.3. Attaching a pole mount adapter (shown upside down)

Several manufacturers offer pole-mount adapters that will fit the UPJ-1P, such as the Ultimate Support System’s (www.ultimatesupport.com) BMB-200K large tripod mounting bracket.

USING THE MLB-UPJ L-BRACKET

A pair of MLB-UPJ L-brackets (Figure 7.4) allows the UPJ-1P loudspeaker to be mounted to a wall, ceiling, or floor. The kit includes two M8 bolts and two rubber washers.

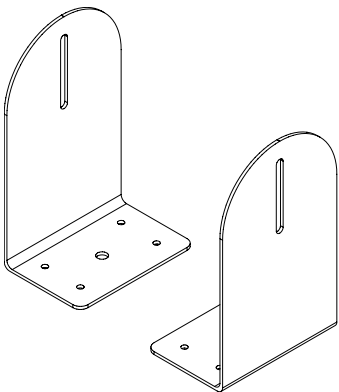

Figure 7.4. MLB-UPJ L-bracket

A single MLB-UPJ L-bracket can be oriented toward or away from the loudspeaker, providing maximum flexibility for positioning and securing the L-bracket according to the needs of the design and/or the venue.

Wall Mount

The MLB-UPJ allows you to mount the UPJ-1P in both a vertical (Figure 7.5) and horizontal orientation (Figure 7.6) for wall mounting.

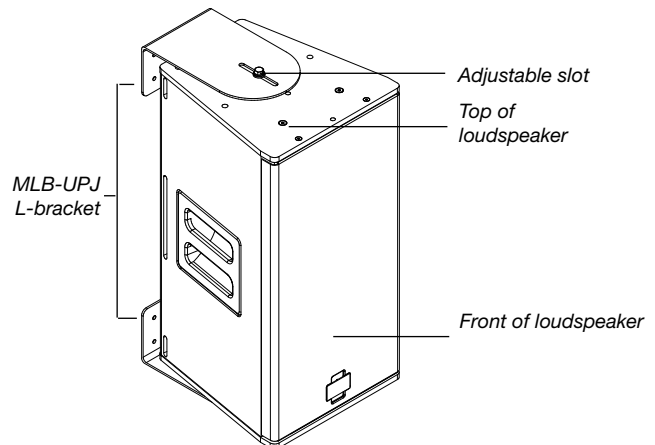

Figure 7.5. Vertically wall-mounting the UPJ-1P

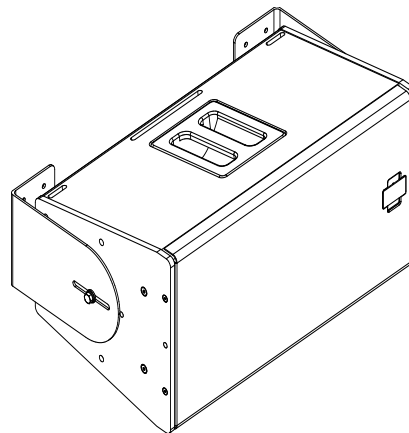

Figure 7.6. Horizontally wall-mounting the UPJ-1P

Ceiling Mount

For mounting the UPJ-1P on a ceiling, underbalcony or canopy area, the MLB-UPJ L-bracket is effective and stable (Figure 7.7).

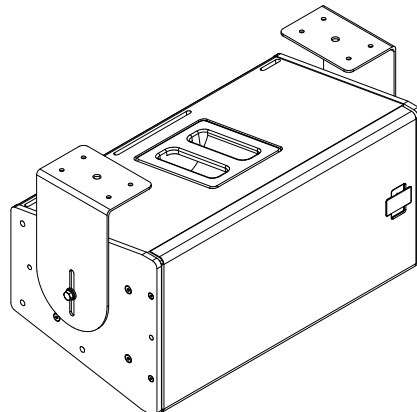

Figure 7.7. Ceiling-mounting the UPJ-1P

Floor Mount

The MLB-UPJ can also be used to mount the UPJ-1P on the floor or stage lip, which is useful for monitoring or front-fill applications, for example (Figure 7.8).

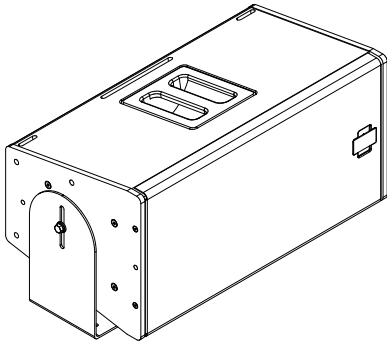

Figure 7.8. Floor-mounting the UPJ-1P



TIP: In any configuration, the MLB-UPJ's adjustment slot can be used to increase or decrease the distance to the mounting surface and achieve the desired angle of the UPJ-1P.



CAUTION: Always use mounting hardware appropriate for the construction of the surface where the MLB-UPJ will be installed.



CAUTION: Always use mounting and rigging hardware that has been rated to meet or exceed the weight being hung.



CAUTION: Make sure that the eyebolts and bolts are tightened securely.

MYA-UPJ MOUNTING YOKE ASSEMBLY

This cradle-style mounting yoke (Figure 7.9) suspends a single UPJ-1P loudspeaker and allows a wide range of horizontal and vertical adjustment. The MEP-UPJ end plate attaches to the MYA-UPJ's bar using two M8 mounting screws (included). A hanging clamp ("C" or "G" type) and a steel safety cable are required to enable the yoke to be used (not supplied as a part of the yoke assembly kit).

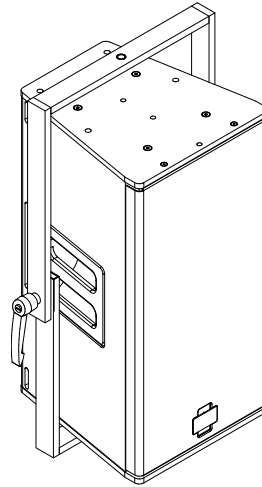

Figure 7.9. The MYA-UPJ is used to suspend a single UPJ-1P cabinet

USING THE MAA-UPJ ARRAY ADAPTER

The MAA-UPJ array adapter (Figure 7.10) allows you to install multiple UPJ-1Ps in both horizontal and vertical arrays. The kit includes two plates, eight M8 screws and rubber washers.

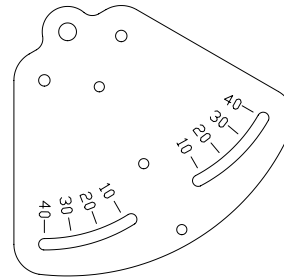

Figure 7.10. MAA-UPJ array adapter

Horizontal Array

The MAA-UPJ array adapter provides a solid connection between multiple loudspeakers to form a horizontal array. The front adjustment slot is used to increase or decrease the distance between the front of the loudspeakers and achieve the desired angle between UPJ-1P loudspeakers. The splay angle can be adjusted continuously from 20° (minimum) to 80° (maximum).



TIP: To create optimum coverage in a horizontal array, the splay between UPJ-1P speakers should be 50° when the horns are in the 80° horizontal by 50° vertical position. Angles of less than 50° between cabinets can create too much interaction between loudspeakers, while angles greater than 50° may create holes in the coverage. For example, a horizontal array of three UPJ-1Ps splayed 50° will have an optimal horizontal coverage of 160° horizontal by 50° vertical.

Pole-Mounting a Horizontal Array

You can pole-mount a horizontal array of two UPJ-1P loudspeakers using a third party pole-mount adapter (Figure 7.11). Several manufacturers offer pole-mount adapters that will fit the MAA-UPJ array adapter, such as Ultimate Support System's (www.ultimatesupport.com) BMB-200K large tripod mounting bracket.

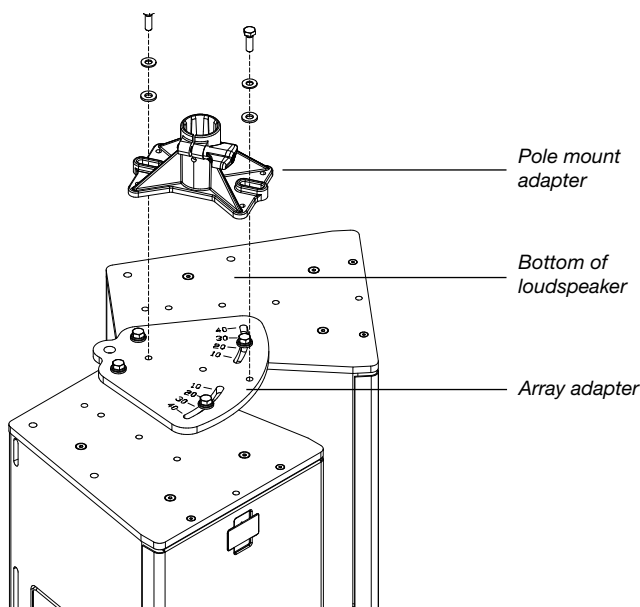

Figure 7.11. A pole-mounted horizontal array of two UPJ-1Ps (shown upside down)



CAUTION: Do not exceed the load rating of the pole-mount adapter and tripod. Two UPJ-1P and array adapters are close to 100 lbs (45.36 kg).

Flying a Horizontal Array

Eyebolts can be also attached to the MEP-UPJ end plate or to the MAA-UPJ to provide pick-up holes for flying a horizontal array (Figure 6.12). In addition, the MAA-UPJ's rear pick-up holes can be used for additional support or better control over vertical coverage of the array.

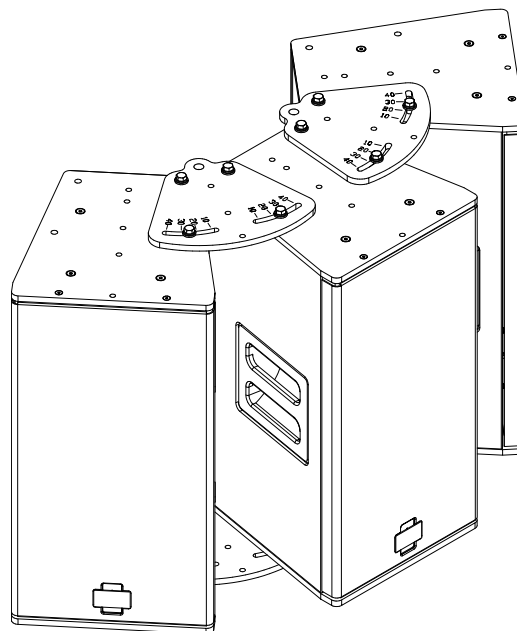

Figure 7.12. Horizontal array of 3 UPJ-1Ps

Vertical Array

The MAA-UPJ array adapter also provides a solid connection between multiple loudspeakers to form a vertical loudspeaker array with two or three cabinets. The front adjustment slot is used to increase or decrease the distance between the front of the loudspeakers and achieve the desired angle between the UPJ-1P loudspeakers. The splay angle can be from 20° (minimum) to 80° (maximum). In addition, the MAA-UPJ's rear pickup holes can be used to provide additional support or better control over the vertical splay between cabinets.



CAUTION: Always use mounting and rigging hardware that has been rated to meet or exceed the weight being hung.

Ceiling Mounting a Vertical Array

In the vertical array configuration (Figure 7.13), the top cabinet is mounted to the ceiling using the MLB-UPJ L-bracket.

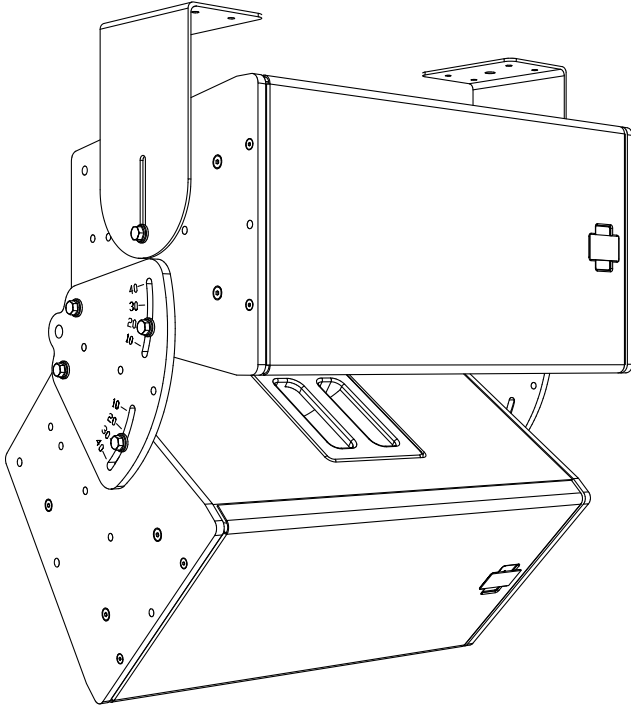

Figure 7.13. Mounting a vertical array of UPJ-1Ps using the MAA-UPJ and the MLB-UPJ

Flying a Vertical Array

Eyebolts can be also attached to the MAA-UPJ to provide pick-up holes for flying a vertical array. In addition, the MAA-UPJ's rear pick-up holes can be used for additional support or better control over vertical coverage of the array (Figure 7.14).

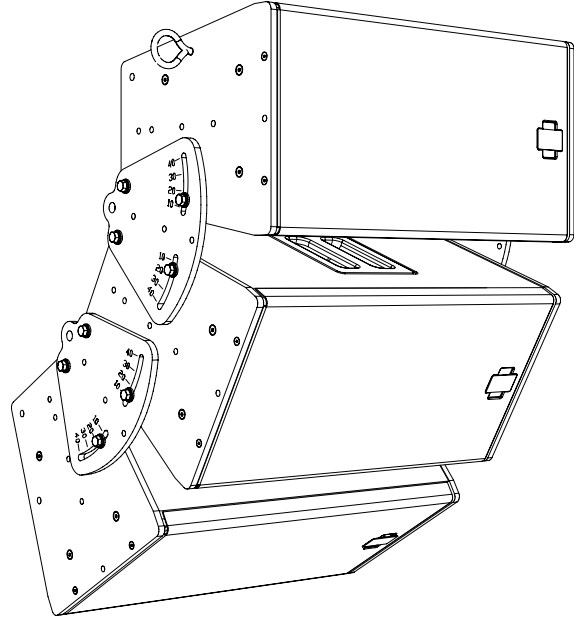

Figure 7.14. Mounting a vertical array of three UPJ-1Ps using the eyebolts in the top cabinet



TIP: To create optimum coverage in a vertical array the splay between UPJ-1P speakers should be 30° when the horns are in the 80° horizontal by 50° vertical position. Angles of less than 30° between cabinets can create too much interaction between loudspeakers and angles greater than 30° can create holes in the coverage. For example, a vertical array of three UPJ-1Ps splayed 30° will have an optimal horizontal coverage of 80° horizontal by 100° vertical.

APPENDIX A

BASIC TROUBLESHOOTING

This section contains possible solutions to some common problems encountered by UPJ-1P users and is not intended to be a comprehensive troubleshooting guide.

The On/Temp. LED does not illuminate and there is no audio.

1. Make sure the AC power cable is the correct type for the regional voltage and that it is securely connected to the AC inlet, then unplug and reconnect the AC cable.
2. Use an AC voltmeter to verify that the AC voltage is within the ranges 90 - 264 V AC.
3. Call Meyer Sound Technical Support.

The On/Temp. LED is illuminated green but there is no sound.

1. Verify that the audio source (mixer, EQ, delay) is sending a valid signal.
2. Make sure the XLR cable is securely fastened to the XLR audio input connector.
3. Verify that the XLR cable is functioning by substituting another cable or by using the cable in question in a working system.
4. Send the audio signal to another loudspeaker to insure signal presence and that the level is within the proper range. Turn the source level down before reconnecting the audio input and increase the level slowly to avoid a sudden blast of sound.
5. If possible, monitor the audio source with headphones.

Hum or noise is produced by the loudspeaker.

1. Disconnect the audio input. If the noise persists, the problem is within the loudspeaker. In this case return the unit to the factory or nearest authorized service center. If the hum ceases, the noise originates somewhere earlier in the signal path.
2. Make sure the XLR cable is securely fastened to the XLR audio input connector.
3. Send the audio signal to another loudspeaker to insure signal presence and that the level is within the proper range. Turn the source level down before reconnecting the audio input and increase the level slowly to avoid a sudden blast of sound.
4. Hum or noise can be produced by a ground loop. Since the UPJ-1P is effectively ground-lifted, the loop must be broken elsewhere in the system.

The audio produced by the loudspeaker is distorted or compressed but the limit light is not illuminated.

1. Make sure the XLR cable is securely fastened to the XLR audio input connector.
2. Send the audio signal to another loudspeaker to insure that the level is within the proper range. Turn the source level down before reconnecting the audio input and increase the level slowly to avoid a sudden blast of sound.
3. Monitor the audio source with headphones.

The audio produced by the loudspeaker is highly compressed and the limit light is constantly yellow.

1. Turn down the level of the input signal to the speaker system.

The On/Temp. LED is illuminated red.

This occurs in conditions where the heatsink temperature reaches 85°C (185°F), indicating that the amplifier is thermally overloaded.

1. Turn down the level of the input signal to the loudspeaker system.
2. Make sure the fan is working properly.
3. Make sure there is sufficient air flow around the unit.
4. Avoid exposing the heatsink to direct sunlight if the ambient temperature is high.

See the Amplification and Limiting, and Amplifier Cooling System sections on page 6 for a complete discussion about the cooling system.

Only the high or low drivers seem to produce sound.

1. Make sure the audio signal is full-range and has not been filtered in a previous stage of the signal chain. If possible, monitor the audio source with high-quality headphones.
2. Send the audio signal to another loudspeaker to insure that the signal is full-range. Turn the source level down before reconnecting the audio input and increase the level slowly to avoid a sudden blast of sound.
3. Use a sine wave and/or pink noise generator to send a variety of frequencies to the loudspeaker.

APPENDIX B

UPJ-1P SPECIFICATIONS

ACOUSTICAL	
Operating frequency range	55 Hz - 20 kHz Note: Recommended maximum operating frequency range. Response depends upon loading conditions and room acoustics.
Free field frequency response	66 Hz - 18 kHz ± 4 dB Note: Measured with 1/3 octave frequency resolution at 4 meters.
Phase response	$\pm 45^\circ$ 750 Hz to 18 kHz
Maximum peak SPL	128 dB Note: Measured with music at 1 meter.
Dynamic range	>110 dB
Coverage	80° x 50° Note: The UPJ horn can be rotated to provide an 80° x 50° coverage pattern in either the horizontal or vertical plane.
Acoustical crossover	2 kHz Note: At this frequency, the transducers produce equal sound pressure levels.
TRANSDUCERS	
Low frequency	One 10" cone driver with neodymium magnet Nominal impedance: 4 Ω Voice coil size: 2" Power-handling capability: 400 W (AES) Note: Power handling is measured under AES standard conditions: transducer driven continuously for two hours with band limited noise signal having a 6 dB peak-average ratio.
High frequency	One 3" compression driver Nominal impedance: 16 Ω Voice coil size: 3" Diaphragm size: 3" Exit size: 0.75" Power-handling capability: 100 W (AES) Note: Power handling is measured under AES standard conditions: transducer driven continuously for two hours with band limited noise signal having a 6 dB peak-average ratio.
Note: The driver is coupled to an 80° x 50° constant-directivity horn.	
AUDIO INPUT	
Type	Differential, electronically balanced
Max. common mode range	± 15 V DC, clamped to earth for voltage transient protection
Connectors	Female XLR input with male XLR loop output
Input impedance	10 k Ω differential between pins 2 and 3
Wiring	Pin 1: Chassis/earth through 220 k Ω , 1000 pF, 15 V clamp network to provide virtual ground lift at audio frequencies Pin 2: Signal + Pin 3: Signal - Case: Earth ground and chassis
DC Blocking	Differential DC blocking on input up to max. common mode voltage
CMRR	>50 dB, typically 80 dB (50 Hz – 500 Hz)
RF filter	Common mode: 425 kHz; Differential mode: 142 kHz
TIM filter	<80 kHz, integral to signal processing
Nominal input sensitivity	0 dBV (1 V rms, 1.4 V pk) continuous average is typically the onset of TPL limiting for noise and music.

Input level	Audio source must be capable of producing a minimum of +20 dBV (10 V rms, 14 V pk) into 600 Ω to produce maximum peak SPL over the operating bandwidth of the loudspeaker.
-------------	--

AMPLIFIERS

Amplifier type	Two-channel complementary power MOSFET output stages (class AB)
Output power	300 W total
	Note: Wattage rating is based on the maximum unclipped burst sine-wave rms voltage the amplifier will produce into the nominal load impedance — low and high channels 30 V rms (42 V pk) into load impedance
THD, IM TIM	< .02%
Load capacity	4 Ω low channel, 16 Ω high channel
Cooling	Forced air cooling over amplifier heatsink

AC POWER

AC power connector	PowerCon with looping output
Voltage selection	Automatic
Safety agency rated operating voltage	100 V AC - 240 V AC; 50/60 Hz
Turn on/turn off points	90 V AC to 264 V AC; 50/60 Hz
	Note: No automatic turn-off voltages. Voltages above 265 V AC are fuse protected but may cause permanent damage to the power supply. Voltages below 90 V AC may result in intermittent operation.

Current Draw

Idle current	0.41 A rms (115 V AC); 0.33 A rms (230 V AC); 0.42 A rms (100 V AC)
Max. long-term continuous current (>10 sec)	3.2 A rms (115 V AC); 1.6 A rms (230 V AC); 3.7 A rms (100 V AC)
Burst Current (<1 sec)	5.0 A rms (115 V AC); 2.5 A rms (230 V AC); 5.8 A rms (100 V AC)

Note: Current draw for a single loudspeaker. Loop out not used.

Ultimate Short-Term Peak Current Draw	17 A pk (115 V AC); 8.5 A pk (230 V AC); 20 A pk (100 V AC)
Inrush Current	15 A pk (115 V AC); 13 A pk (230 V AC); 15 A pk (100 V AC)

PHYSICAL

Enclosure	Multi-ply hardwood
Finish	Black textured
Protective grille	Powder-coated hex stamped steel
Rigging	QuickFly rigging options
Dimensions	11.15" W x 22.43" H x 12.25" D (283 mm x 570 mm x 311 mm)
Weight	46.00 lbs (20.87 kg)

