



## Operating Instructions

Translation of the original instruction

Version 6.3  
Released: 6.12.2016



## Important Information, Please Read Before Use!

KLING & FREITAG GmbH  
Junkersstrasse 14  
D-30179 Hannover  
TEL +49 (0) 511- 969 97-0  
FAX +49 (0) 511- 67 37 94  
[www.kling-freitag.de](http://www.kling-freitag.de)



# ACCESS SYSTEM

Thank you for your decision to buy a KLING & FREITAG product. To guarantee a trouble-free operating of the equipment and to enable the KLING & FREITAG ACCESS System to achieve its full potential, please read the operating instructions carefully before use.

With the purchase of an ACCESS System, you have acquired a speaker system with the highest possible quality and performance capabilities.

As the owner of this system, you now have a versatile and highly professional tool which, when operated properly, is a true pleasure to use.

## Symbols in User's Manual



### Warning

This symbol indicates the possibility of life-threatening danger and a health risk for persons. Not following these instructions may result in serious health problems including potentially fatal injuries.



### Caution

This symbol indicates a possibly dangerous situation. Not following these instructions may cause minor injuries or property damage.



### Important

This symbol gives instructions for the proper use of the described products. Not following these instructions may cause malfunctions or property damage.

## Information about this User's Manual

User's Manual ACCESS System Version 6.0, 06.12.2016

© by André Figula, Kling & Freitag GmbH, 1995 - 2016; all rights reserved.

All specifications in this manual are based on information available at the time of publishing for the features and safety guidelines of the described products.

Technical specifications, dimensions, weights and properties are not guaranteed.

The manufacturer reserves the right to make product alterations within legal provisions as well as changes to improve product quality.

**All persons who use the speaker system must have this guide and all further information for safe operations available to them during assembly, disassembly, and use.**

We appreciate any input with suggestions and improvements for this manual. Please send this to us at the following address:

info@kling-freitag.de or to:

KLING & FREITAG GMBH Junkersstr.14 D-30179 Hannover

Phone +49 (0) 511 - 96 99 70 Fax +49 (0) 511 - 67 37 94

<b>Contents</b>	
<b>Chapter</b>	<b>Page</b>
1. General Safety Instructions for Using Speakers	5
2. The ACCESS System Components	7
3. The Top Speakers	9
3.1 T5 Mid/High System	9
3.1.1 T5 Applications	9
3.1.2 T5 Technical Specifications	9
3.1.3 T5 Measuring Charts	10
3.1.4 T5 Dimensions	10
3.2 T9 Mid/High System	11
3.2.1 T9 Applications	11
3.2.2 T9 Technical Specifications	11
3.2.3 T9 Measuring Charts	12
3.2.4 T9 Dimensions	12
4. The Subwoofers	13
4.1 Short-Circuit Fuses in the K&F Subwoofer Systems	13
4.1.1 Risks of using High Performance Power Amplifiers	13
4.1.2 Identifying the Models with Short-Circuit Fuses	13
4.1.3 Add-On Kits for Subwoofers without Short-Circuit Fuses	13
4.1.4 Specification of the Fuses	14
4.1.5 Replacement and Positions of the Short-Circuit Fuses	14
4.2 B5 Subwoofer System, Specifications	15
4.2.1 B5 Applications	15
4.2.2 B5 Technical Specifications	15
4.2.3 B5 Measuring Charts	16
4.2.4 B5 Dimensions	16
4.3 B10 Subwoofer System	17
4.3.1 B10 Applications	17
4.3.2 B10 Technical Specifications	17
4.3.3 B10 Measuring Charts	18
4.3.4 B10 Dimensions	18
4.4 Using the ACCESS B5 / B10 with other K&F Systems	19
5. Pin Diagrams of Connectors and internal Wiring	19
5.1 ACCESS T5 Pin Diagrams of Connectors and Wiring	19
5.2 ACCESS T9 Pin Diagrams of Connectors and Wiring	19
5.3 ACCESS B5 Pin Diagrams of Connectors	20
5.4 ACCESS B10 Pin Diagrams of Connectors	20
6. Safety Instructions for Controller and Connector Panel	21
7. K&F CD 44 Digital System Controller	22
8. The ACCESS Controllers	22
8.1 The ACCESS C5/9 Controller	23
8.1.1 Connectors, Controls and Displays and of the C5/9	23

8.1.2	C5/9 Controller Technical Specifications	25
8.1.3	Pin Diagrams of the C5/9 Controller's In- and Outputs	25
8.2	The ACCESS C10 Controller	26
8.2.1	Connectors, Controls and Displays and of the C10	26
8.2.2	C10 Controller Technical Specifications	29
8.2.3	Pin Diagrams C10 Controller In- and Outputs	29
9.	The ACCESS Connector Panels	30
9.1	Connectors of the Connector Panels CP1 and CP3	30
9.1.1	Connector Panel CP1 und CP3 Technical Specifications	31
9.1.2	CP1 and CP3 Pin Diagrams of In- and Outputs	32
9.2	Connectors of the Bass Connector Panels CP1-B und CP3-B	33
9.2.1	Connector Panel CP1-B und CP3-B Technical Specifications	34
9.2.2	CP1-B and CP3-B Pin Diagrams of In- and Outputs	35
10.	Connecting Instructions for the ACCESS System	36
10.1	Wiring	36
10.2	Avoiding Ground Loops	37
10.2.1	What is a Ground Loop?	37
10.2.2	Avoiding Ground Loops	37
11.	Recommended Amplifier Performance for the ACCESS System	38
11.1	Correct Bass and Top Speaker Ratio	39
12.	Mounting Instructions for Loudspeakers	40
12.1	Mounting and Stacking the ACCESS Systems	41
12.2	Using the MAN Rigging Points	42
13.	Operating the ACCESS SYSTEM	43
14.	Connection Diagrams	44
14.1	ACCESS System with Controller C5/9 and CP1/3	44
14.2	ACCESS System with Controller C5/9, no Connector Panel	45
14.3	Optimised Operations with B10, C10 and CP1/3-B	46
14.4	Optimised Operations with B10, C10 without CP1/3-B	47
15.	Sound Pressure Dispersion of Mid-High Systems T5 & T9	48
15.1	Sound Pressure Dispersion of combined Mid-High Systems	49
15.2	Sound Pressure Dispersion in Relation to the Position	50
16.	Basic Rules for the Alignment of the ACCESS Systems	51
17.	Examples of Configurations and Applications	53
18.	Accessories for the ACCESS System	58
19.	Regulations for Disposal	60
19.1	Germany:	60
19.2	EU, Norway, Island, and Liechtenstein (not Germany):	60
19.3	Other countries	60
20.	Included Safety and Mounting Instructions for Loudspeakers and Accessories	

## 1. General Safety Instructions for Using Speakers

### Mounting the speakers



**Warning**

To prevent injury or property damage, this equipment must be securely placed on the floor or mounted in a different manner according to the mounting instructions on page 40 (Mounting Instructions for Loudspeakers). Speakers, which are stacked, must be secured with safety straps. Please note that speakers can move as a result of vibrations. To prevent them from falling from their mounted position, they must be secured properly. If the weight of the speaker exceeds 20 kg then it is necessary for two people to carry it. Speakers may only be mounted to walls and ceilings by qualified personnel. The speakers must be hung by using the two designated MAN flying points on the sides of the speaker. The same applies when lifting and aligning the speakers. Only connections designed to fit the flying points should be used. If in doubt, please consult the manufacturer.

The bass system ACCESS B10 is not designed for flown applications.

Never use signal cables or power cords for suspending, aligning or securing the systems. When laying the connecting cables, make sure that nobody can trip.

Never hang more than two speakers under one another without using the designated Kling & Freitag rigging equipment.

Ensure that all installation connections comply with the applicable safety guidelines and that the size and strength are sufficient. Further instructions are in our user's manual for assembly equipment and in the general safety instructions for speakers and accessories.

For mobile and fixed installations, use only mounting accessories from Kling & Freitag, if possible.

Speakers and mounting accessories must be visually examined at regular intervals. If there are signs of wear, they must be replaced immediately. Furthermore, screwed connections of supporting parts must be checked routinely.

### Protecting the speakers / avoiding fire hazard



**Warning**

In general, audio signals should not be overdriven. This may be caused by mixing consoles, equalizers, effect equipment, etc. and should be indicated on this equipment. When a power amplifier is overloaded at the output (clipping), then the amplifier should activate a clipping warning signal. Power amplifiers can also be overloaded at the input circuit without the amplifier signalling the clipping, i.e. when there is not sufficient headroom in the input circuit. We, therefore, recommend turning up the power amplifiers all the way and adjusting the level before the power amplifier in order to avoid overloading the input circuit. In any case, the signal must be reduced as soon as it sounds unnaturally distorted.

- To protect the speakers from being destroyed and to avoid fire hazard, they should only be operated with professional power amplifiers with the following specifications:
- Amplification according to the instructions in the chapter Recommended Amplifier Performance for the ACCESS System from page 38 onwards.
- Integrated clipping limiter
- without using a Kling & Freitag controller (not recommended):
  - Integrated or preceding subsonic filter (approx. 20 Hz, min. 12 dB / octave)
  - Power amplifiers with power specifications lower than those stated from page 39 onwards must be supplied with a clip limiter for speaker protection, even if they are operated with a Kling & Freitag system controller.

If you wish to use a speaker with a power amplifier that does not fulfil these specifications, then the speaker should be controlled using a Kling & Freitag system controller with limiter function. This is the only way overloading and the risk of fire can be avoided. The results of such a power amplifier defect cannot be avoided by the controller.

For damage caused by overloading or use with power amplifiers other than those recommended above or with amplifiers with higher output power, Kling & Freitag GmbH does not assume warranty and excludes liability for possible consequential damage.

**The following signals may damage the speakers**

- permanent high-pitched signals with high frequency and continuous noise from feedback.
- permanently distorted signals with high power.
- noises, which occur when the amplifier is on while equipment is being connected, disconnected or switched on.

**Important****Do not install speakers in any of the following places:**

- where the speakers are permanently exposed to direct sunlight
- where the speakers are exposed to high moisture or rain
- where the speakers are exposed to strong vibrations and dust.

**Damage caused by the speakers' magnetic fields**

Speakers are permanently surrounded by a magnetic field, even when they are not operating. Therefore, during transport and placement of the speakers, it is important to ensure that there is always approx. 1 m between the speakers and magnetic data media and computer/video monitors.

**Preventing hearing damage**

To prevent the risk of hearing damage, avoid being too close to operating speakers, even if the volume level seems to be low enough. In general, volume levels over 90 dB can cause hearing damage.

**Caution**

## 2. The ACCESS System Components

The ACCESS SYSTEM consists of the perfectly tuned system components including speakers, system controllers and connector panels. This manual describes up through and including chapter 8 each individual component. Subsequently, connecting instructions and system configurations are mentioned and explained based on example.

### ACCESS Mid-High Systems:

<p>ACCESS T5 Description as of page 9</p>	<p>ACCESS T9 Description as of page 11</p>

### ACCESS Bass Systems:

<p>ACCESS B5 Description as of page 15</p>	<p>ACCESS B10 Description as of page 17</p>

**ACCESS System Controller:**

System Controller ACCESS C5/9  
Description as of page 23



System Controller ACCESS C10  
Description as of page 26



**Connector Panels:**

Connector Panel CP1 / CP3 for operations with the ACCESS C5/9 Controller.  
Description as of page 30

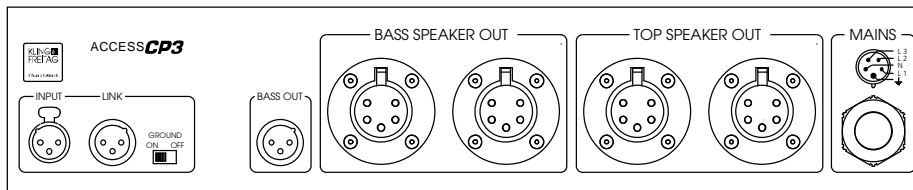

Connector Panel CP1-B / CP3-B for operations with the ACCESS C10 Controller  
Description as of page 33

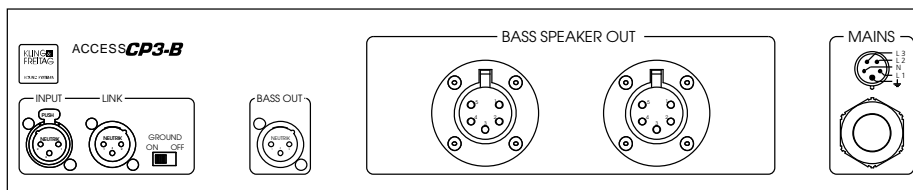



### 3. The Top Speakers

#### 3.1 T5 Mid/High System

##### 3.1.1 T5 Applications

The ACCESS T5 is a horn-loaded high-end sound system with a consistent and homogeneous dispersion pattern of 50° x 40°, and is, therefore, predestined for use in clusters and arrays. The areas of use range from discotheques and live sound coverage to large events and mega open-air. The T5 meets all demands at the highest level – from techno to classic. With wide-band highest sound pressure levels exceeding 140 dB and an optimal audio quality, a minimum number of units is necessary. This allows for maximum efficiency for set-up and dismantling.

##### 3.1.2 T5 Technical Specifications

Design	2-way horn loaded
Frequency response -10 dB	100 Hz - 20 kHz (with Controller C5/9)
Frequency response ± 3 dB	130 Hz - 19 kHz (with Controller C5/9)
Nominal coverage angle	50° x 40° (hor. x vert.)
Directivity index (DI)	14 (+1.5/-2) 630 Hz - 16 kHz
Nominal power handling	500 W low-mid, 120 watts mid-high
Sensitivity 1 W/1 m	110 dB low-mid, 113 dB mid-high
Max. SPL	143 dB (SPL peak/1 m)
Components	12" chassis with conical horn 5" compression driver with CD horn / 12" diaphragm 1.5" compression driver with CD horn / 3" diaphragm
Crossover	All-pass filter optimises phase response and delay time between the 5" and 12" driver
Impedance	5Ω low-mid, 10Ω mid-high
Connectors	EP-5 male / female MID: 1+ / 2-, HIGH: 3- / 4+
Enclosure	Trapezoid with 2 cluster angles 4°/15° 15 mm birch plywood with highly resistant black structured paint 4 ergonomic butterfly handles 4 100 mm transport castors mounted on the rear, ball proof front grille with exchangeable black acoustic foam
Rigging	2 MAN CF4T rigging points, 2 MAN HWKB strap attachments for securing straps
Dimensions	600 x 900 x 750 mm without castors (W x H x D)
Weight incl. Castors	92 kg
Options	Transport cover with butterfly catches, MAN/K&F flying hardware, ATM modular cradle system, special finish in RAL colours, All Weather / Outdoor version

### 3.1.3 T5 Measuring Charts

Frequency response "on axis" with Controller C5/9

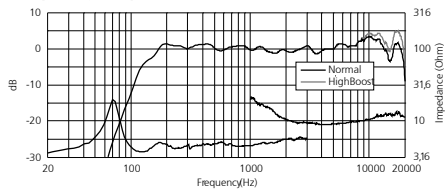

Horizontal frequency response "off axis"

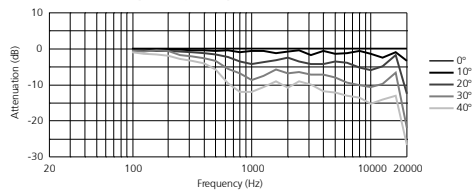

Vertical frequency response "off axis up"

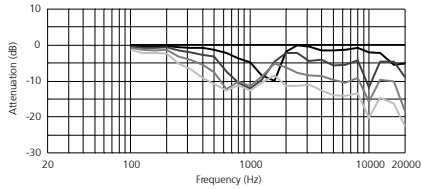

Vertical frequency response "off axis down"

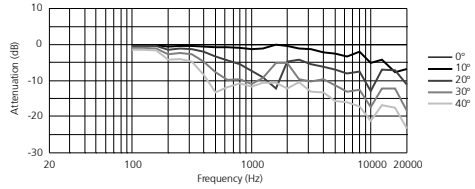

Beamwidth

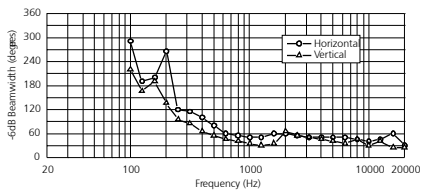

Q-Index

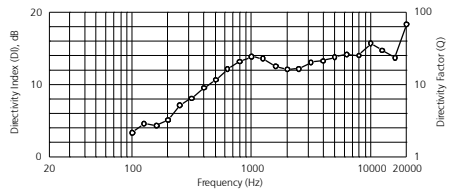

All measurements: Far field conditions. Frequency response 1/6 octave averaged, polar and directivity data 1/3 octave averaged. Kling & Freitag reserves the right to change all specifications without notice. We are not liable for misprints.

### 3.1.4 T5 Dimensions

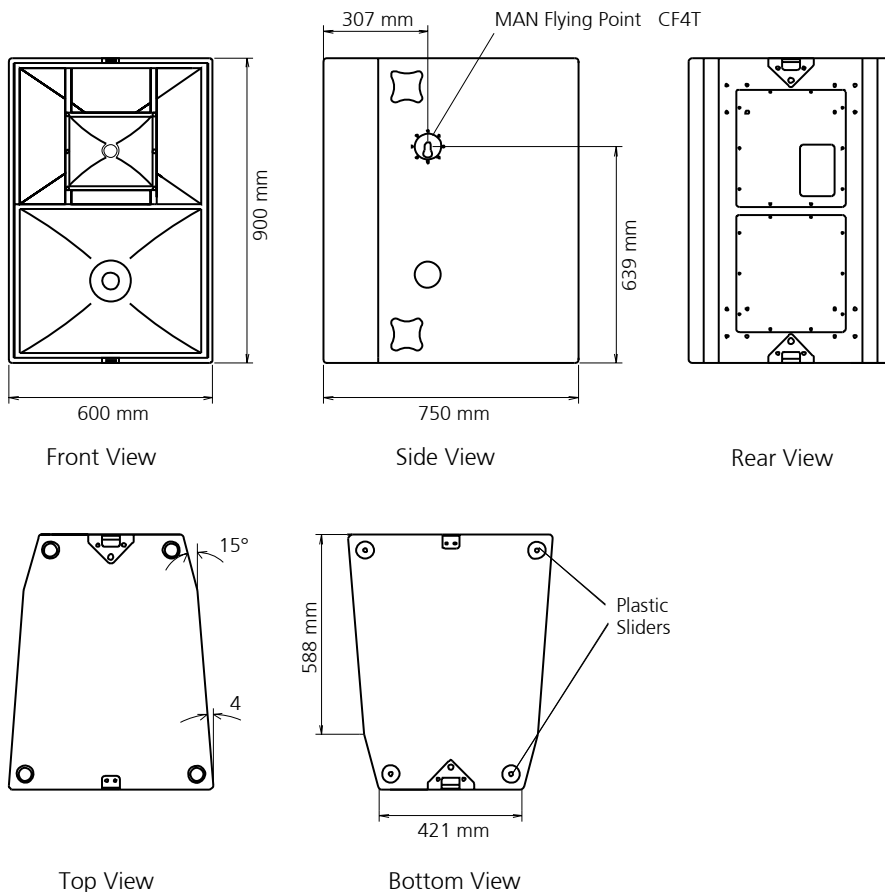

## 3.2 T9 Mid/High System

### 3.2.1 T9 Applications

The ACCESS T5 is a horn-loaded high-end sound system with a consistent and homogeneous dispersion pattern of 90° x 40°. It is, therefore, extremely well suited for small to medium coverage requirements with just one system per side such as live concerts in clubs and sound coverage in discotheques. By using pair clusters with another T9 or large arrays with the fully compatible T5, it is possible to use the equipment at large events and mega open-air concerts. The T9 meets all demands at the highest level – from techno to classic. With wideband highest sound pressure up to 139 dB and an optimal audio quality, a minimum number of units is necessary. This allows for maximum efficiency for set-up and dismantling.

### 3.2.2 T9 Technical Specifications

Design	2-way horn loaded
Frequency response -10 dB	100 Hz - 19 kHz (with Controller C5/9)
Frequency response ± 3 dB	130 Hz - 17 kHz (with Controller C5/9)
Nominal coverage angle	90° x 40° (hor. x vert.)
Directivity index (DI)	12 (+1.5/-1.5) 500 Hz - 20 kHz
Nominal power handling	500 watts low-mid, 120 watts mid-high
Sensitivity 1 W/1 m	108 dB low-mid, 110 dB mid-high
Max. SPL	139 dB (SPL peak/1 m)
Components	12" chassis with conical horn 5" compression driver with CD horn / 12" diaphragm 1.5" compression driver with CD horn / 3" diaphragm
Crossover	All-pass filter optimises phase response and delay time between the 5" and 12" driver
Impedance	5Ω low-mid, 10Ω mid-high
Connectors	EP-5 male / female MID: 1+ / 2-, HIGH: 3- / 4+
Enclosure	Trapezoid with 2 cluster angles 4°/15° 15 mm birch plywood with highly resistant black structured paint 4 ergonomic butterfly handles 4 100 mm transport castors mounted on the rear, ball proof front grille with exchangeable black acoustic foam
Rigging	2 MAN CF4T flying points, 2 MAN HWKB strap attachments for securing straps
Dimensions	600 x 900 x 750 mm without castors (W x H x D)
Weight incl. Castors	92 kg
Options	Transport cover with butterfly catches, MAN/K&F flying hardware, ATM modular cradle system, special finish in RAL colours, All Weather / Outdoor version

### 3.2.3 T9 Measuring Charts

Frequency response "on axis" with Controller C5/9

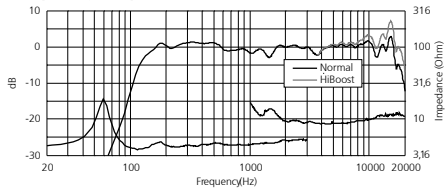

Horizontal frequency response "off axis"

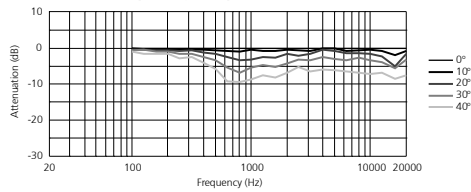

Vertical frequency response "off axis up"

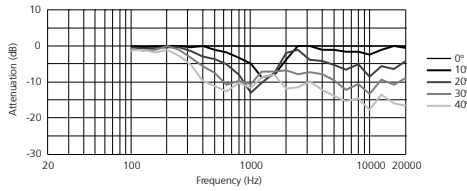

Vertical frequency response "off axis down"

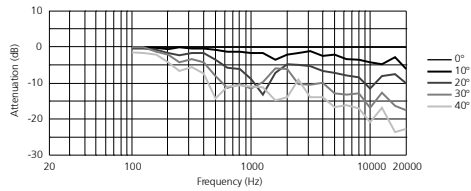

Beamwidth

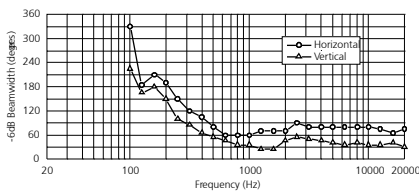

Q-Index

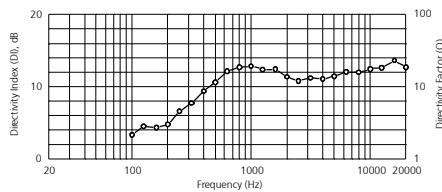

All measurements: Far field conditions. Frequency response 1/6 octave averaged, polar and directivity data 1/3 octave averaged. Kling & Freitag reserves the right to change all specifications without notice. We are not liable for misprints.

### 3.2.4 T9 Dimensions

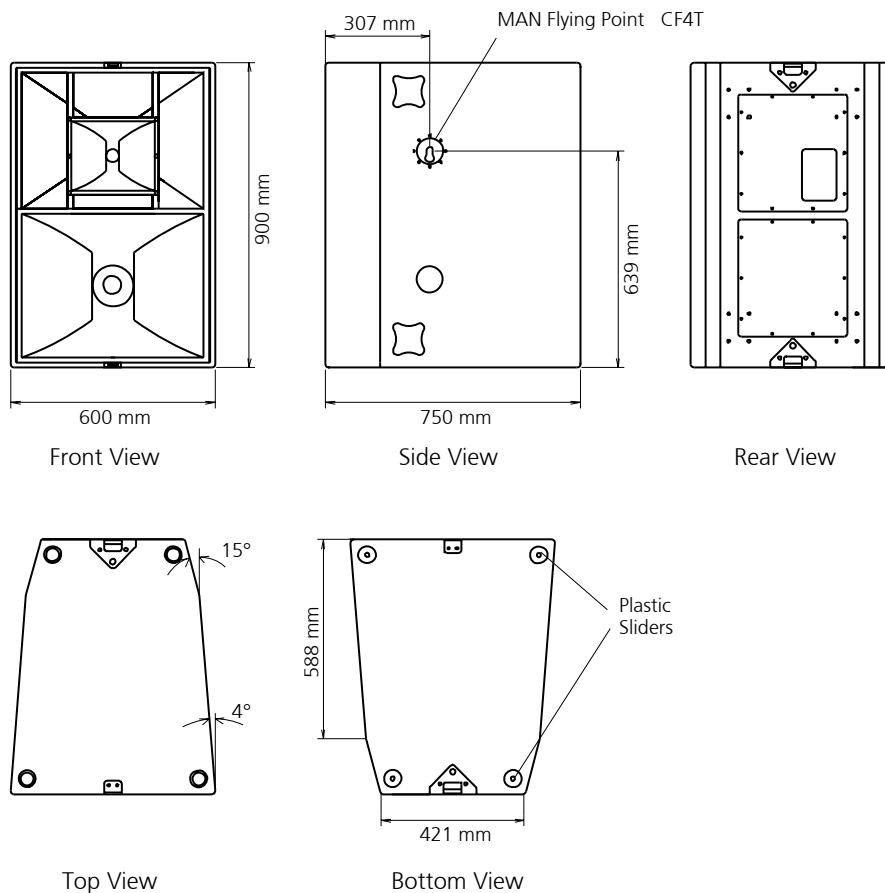

## 4. The Subwoofers

### 4.1 Short-Circuit Fuses in the K&F Subwoofer Systems

#### 4.1.1 Risks of using High Performance Power Amplifiers

In recent years, power amplifiers have achieved increasingly higher levels of performance. Some of them can be operated with low-impedance loads. There are, therefore, strong power amplifiers that can reliably work with impedances below 1  $\Omega$ . This development has led to an increased safety risk during defective operations.

When there is a defect, such as a short circuit in the speaker chassis or on the crossover, it is possible that the power amplifier – despite existing protective switches – will not shut off. Long cable lengths and contact resistance on the plug connections may already have an electrical resistance of 1  $\Omega$ . As a result, the power amplifier cannot “recognise” the operations as being defective and, therefore, delivers unacceptable high currents. In the worst-case scenario, this may lead to fire damage (hot and charred wiring / connectors as a result of overloaded wires and connectors, etc.). *The current safety regulations are lagging behind this development and are thus not up-to-date with this modern technology.*

Normally, the K&F System Controller prevents the speaker from being overloaded. The results of such a defect cannot be avoided by the controller.

In order to give consideration to this development, Kling & Freitag now equips its subwoofer systems with short circuit fuses at the signal input. These fuses do not offer protection for the speaker, but do reduce the risk of consequential damage in the case of a short circuit.

For systems, which are not serially equipped with a short circuit fuse, Kling & Freitag offers simple add-on kits so that you can adapt your existing subwoofer systems to the current power amplifier development.

#### 4.1.2 Identifying the Models with Short-Circuit Fuses

The subwoofer systems, which are serially equipped with short-circuit fuses can be identified as follows; both mentioned stipulations must be fulfilled:

POWER:	700W	XO-ON	OFF
		IMP:	6 $\Omega$   8 $\Omega$
		Zmin:	4 $\Omega$   6 $\Omega$
		SER.-NO.:	2508000070
		WT:	51,5kg

Diagram: 4-pin connector with terminals 1+, 1-, 2-, 2+. Text: all pins parallel to out.

Callout 1: The first two digits must be at least 25.

Callout 2: The next two digits must be at least 08.

#### 4.1.3 Add-On Kits for Subwoofers without Short-Circuit Fuses

All subwoofer systems, which are not serially equipped with short circuit fuses, can be, if required, easily and inexpensively upgraded even by yourself.

An instruction manual for this upgrade is delivered with the add-on kit.

#### 4.1.4 Specification of the Fuses

The fuses in all models have the following identical specifications:

##### **Bussmann S 506-8A slow**

When necessary, these fuses may only be replaced with the aforementioned original fuse.



#### 4.1.5 Replacement and Positions of the Short-Circuit Fuses

When the fuse is blown, then the chassis is most likely already ruined, as the fuse just prevents consequential damage resulting from a short circuit of the chassis. A disassembly of the chassis is, therefore, unavoidable.

The fuse holder of the subwoofers is mounted on the signal wiring behind the input connector. The ACCESS subwoofers have 2 fuses; one for each of the parallel operating chassis.

When replacing the fuse, the lid of the terminal with the signal connectors must be screwed off to reach the fuse holder.

## 4.2 B5 Subwoofer System, Specifications

### 4.2.1 B5 Applications

The ACCESS B5 is a high-performance subwoofer system of the ACCESS Series. It is fully compatible with all existing Kling & Freitag speaker products and shows off all its qualities here too. Because of its high efficiency and technical perfection, the B5 is used in the high quality service segment, at discotheques and live sound coverage as well as venues with fixed installations such as theatres and multimedia facilities. When used in arrays with the optimally matched top speakers T5 and T9, the possibilities of use expand to include large events and mega open airs. The T9 meets all demands at the highest level – from hard rock to classic.

### 4.2.2 B5 Technical Specifications

Design	3 chamber band pass, 6 <sup>th</sup> order
Frequency response -10 dB	34 Hz - 400 Hz
Frequency response $\pm$ 3 dB	45 Hz - 190 Hz
Crossover frequencies	max. 180 Hz, 130 Hz with controller C5/9
Nominal power handling	1200 W
Sensitivity 1 W/1 m	101 dB (45 Hz - 200 Hz)
Max SPL	136 dB (SPL peak/1 m)
Components	18" long excursion transducers (2)
Impedance	1 x 4 $\Omega$ With option 'EP-5 instead of Speakon': 2 x 8 $\Omega$
Connectors	Sp.1: 2- / 3+-, Sp.2: 1- / 4+
Enclosure	Trapezoid with 2 cluster angles 4°/15° 15 mm birch plywood with highly resistant black structured paint 4 ergonomic butterfly handles 4 100 mm transport castors mounted on the rear, ball proof front grille with exchangeable black acoustic foam
Rigging	2 MAN CF4T flying points, 2 MAN HWKB strap attachments for securing straps
Dimensions	600 x 900 x 750 mm without castors (W x H x D)
Weight incl. castors	82 kg
Options	Transport cover with butterfly catches, special finish in RAL colours, All Weather / Outdoor version

**4.2.3 B5 Measuring Charts**

Frequenzgang "on axis"

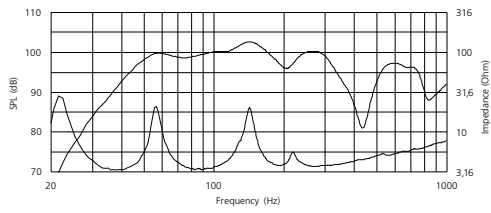

Frequenzgang "on axis" mit Controller

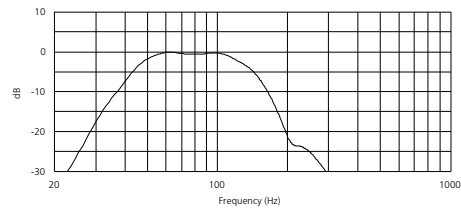

Alle Messungen unter Freifeldbedingungen. Frequenzgangdiagramme 1/6 Okt. geglättet. Technische Änderungen, die der Verbesserung der Produkte dienen, behalten wir uns vor. Irrtümer vorbehalten. Subject to change without notice.

**4.2.4 B5 Dimensions**

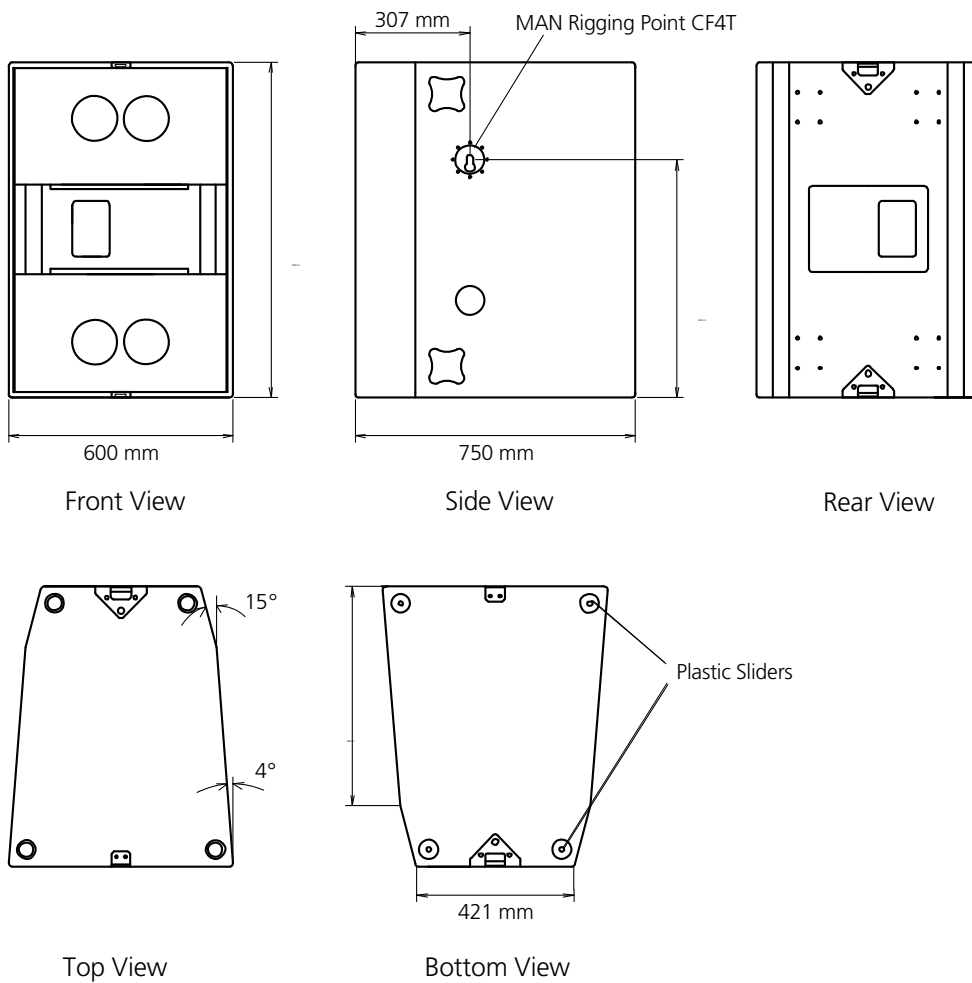



## 4.3 B10 Subwoofer System

### 4.3.1 B10 Applications

The B10 is a universally usable high-performance subwoofer system for the reproduction of low to very low frequencies. The B10 has been created to be used as the optimal addition to the ACCESS Series. It is fully compatible with all existing Kling & Freitag speaker products and shows off all its qualities here too. Because of its high efficiency and technical perfection, the B10 is used in the high quality service segment, at discotheques and live sound coverage as well as venues with fixed installations such as theatres and multimedia facilities. The B10 allows for direct operation with ACCESS top speakers T5 and T9 as well as a phase-correct parallel operation with the bass system ACCESS B5. The B10 meets all demands at the highest level – from techno to classic. The B10 can be operated with the K&F controllers C5/9, C10 and C2.

### 4.3.2 B10 Technical Specifications

Design	3 chamber band-pass horn enclosure
Frequency response -10 dB	31 Hz - 320 Hz (without controller)
Frequency response $\pm 3$ dB	38 Hz - 260 Hz (without controller)
Crossover frequencies	max. 180 Hz, 130 Hz with controller C5/9
Nominal power handling <sup>1)</sup>	1400 W
Programme power handling <sup>2)</sup>	2800 W
Recommended amplification	2 - 3 kW @ 4 $\Omega$
SPL 1 W/1 m	103 dB (40 Hz - 180 Hz)
Max. SPL	140 dB (SPL peak/1 m)
Components	18" long excursion transducers (2)
Impedance	2 x 8 $\Omega$
Connectors	With option 'EP-5 instead of Speakon': 1 x 4 $\Omega$ EP-5 male / female, Sp.1: 2- / 3 +, Sp.2: 1- / 4 +
Enclosure	15 mm birch plywood with highly resistant black structured paint 8 ergonomic butterfly handles 4 100 mm transport castors mounted on the rear, ball proof front grille with exchangeable black acoustic foam
Dimensions	600 x 1350 x 880 mm w/o castors (W x H x D)
Weight incl. castors	120 kg
Options	Transport cover with butterfly catches, special finish in RAL colours
<sup>1)</sup> Long term RMS power capability measured with pink noise signal, reduced bandwidth 40 Hz - 400 Hz, Testing period: 2 hours	
<sup>2)</sup> Long term RMS power capability measured with 50% duty cycle, reduced bandwidth 40 Hz - 400 Hz, Testing period: 2 hours	

### 4.3.3 B10 Measuring Charts

#### Frequenzgang "on axis"

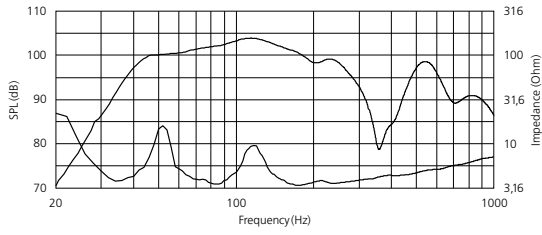

Alle Messungen unter Freifeldbedingungen. Frequenzgangdiagramme 1/6 Okt. geglättet.  
 Technische Änderungen, die der Verbesserung der Produkte dienen, behalten wir uns vor. Irrtümervorbehalten. Subject to change without notice.

### 4.3.4 B10 Dimensions

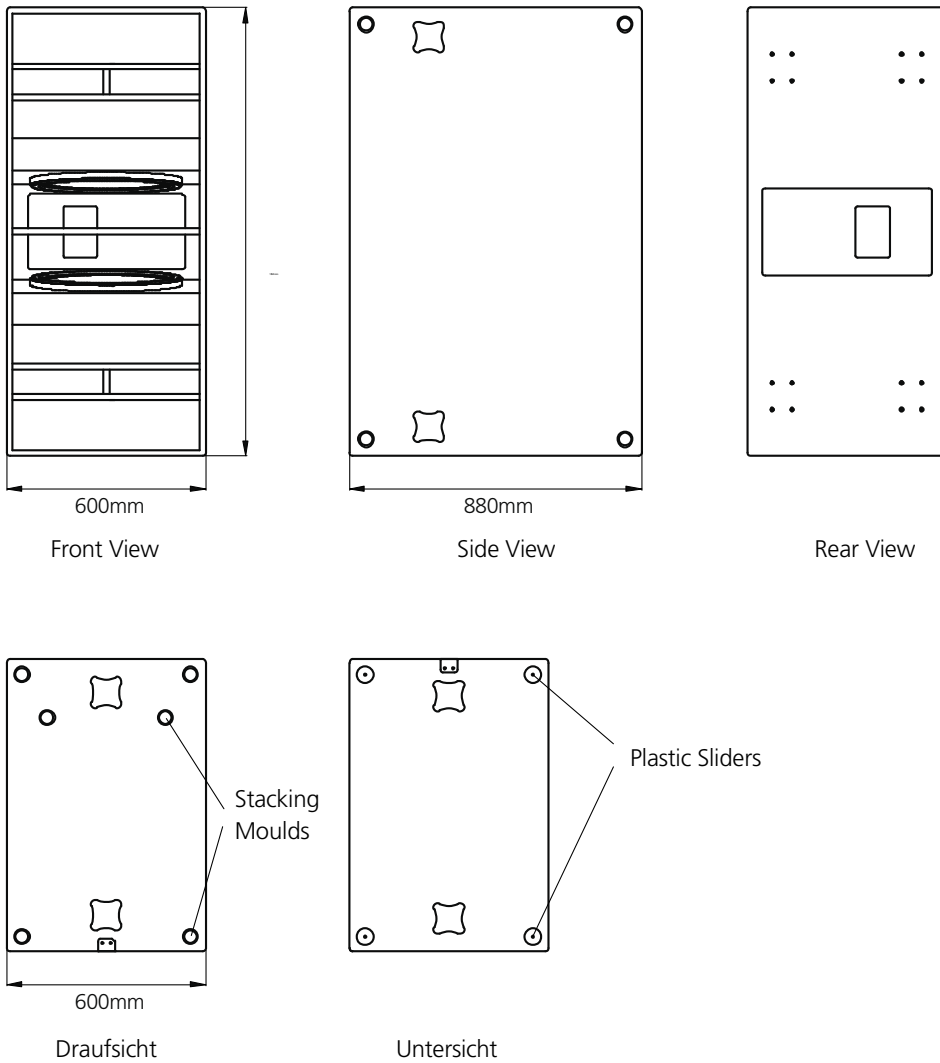

### 4.4 Using the ACCESS B5 / B10 with other K&F Systems

The bass systems B5 and B10 are also ideally suited as subwoofers for use with all models of the Kling & Freitag CA Series.

In order to guarantee an optimal tuning with the other K&F systems, it is necessary to operate them via the K&F C2 System Controller. Additionally, the B10 can be operated via the C10 Controller, although the K&F Full Range Systems are operated via the C2 Controller in full-range mode. Further information is available in the User's Manual for the K&F C2 Controller.

If the CA Series and an ACCESS Subwoofer System are to be operated by another universal controller, K&F will readily provide assistance upon request.

## 5. Pin Diagrams of Connectors and internal Wiring

### 5.1 ACCESS T5 Pin Diagrams of Connectors and Wiring

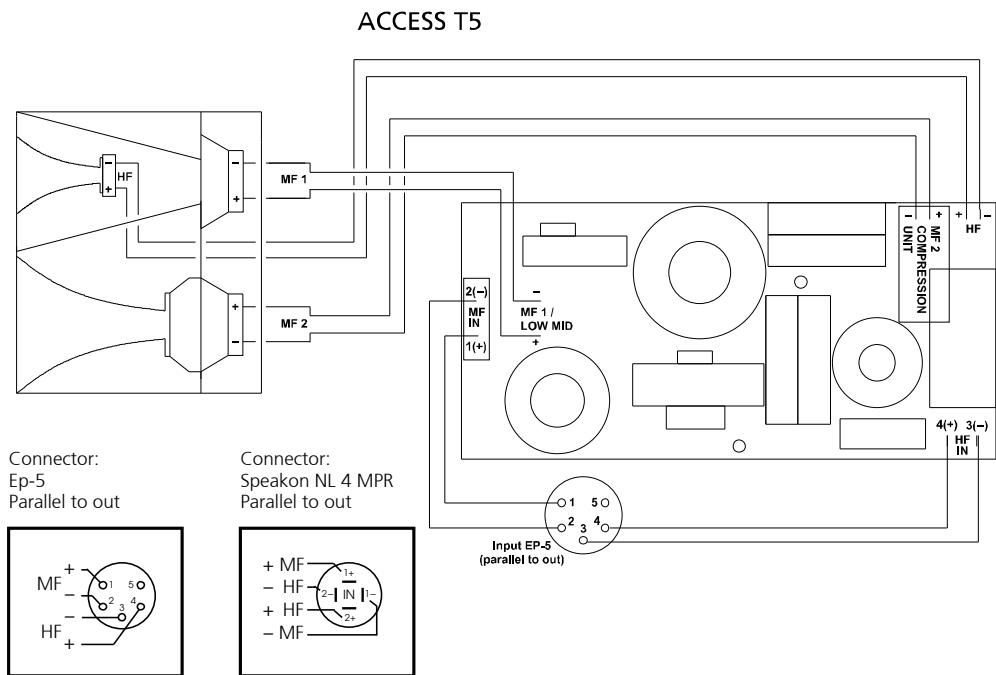

### 5.2 ACCESS T9 Pin Diagrams of Connectors and Wiring

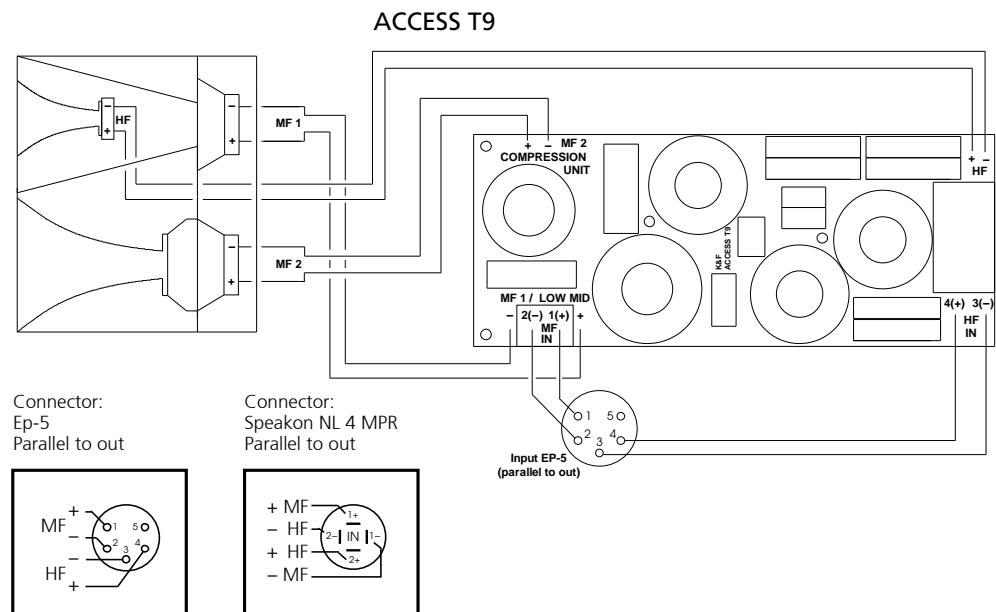

### 5.3 ACCESS B5 Pin Diagrams of Connectors

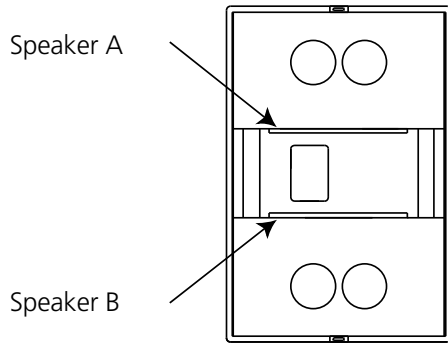

Connector:  
Speakon NL 4 MPR  
1+ / 1-

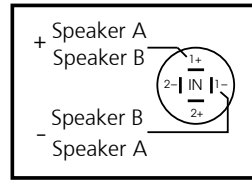

With option 'EP-5 instead of Speakon':

Connector:  
Ep-5  
Parallel to out

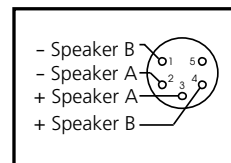

### 5.4 ACCESS B10 Pin Diagrams of Connectors

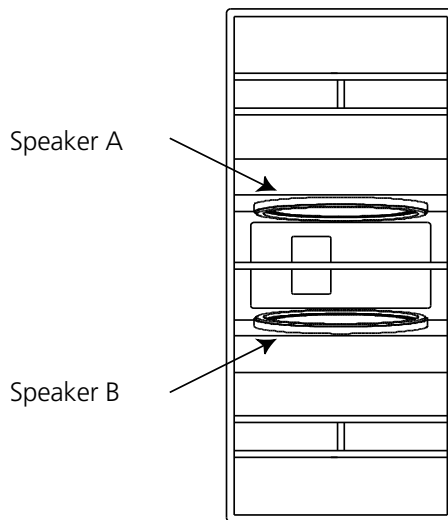

Connector:  
Speakon NL 4 MPR  
1+ / 1-

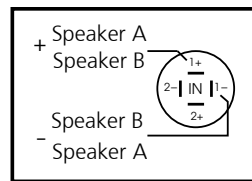

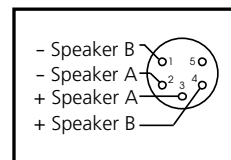

With option 'EP-5 instead of Speakon':

Connector:  
Ep-5  
Parallel to out

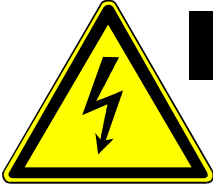

## 6. Safety Instructions for Controller and Connector Panel

	<b>ACHTUNG</b> Risk of electric shock! Do not open the units!	
<b>Warning: To avoid electric shock hazard, do not expose this appliance to rain or moisture. The enclosures may only be opened by qualified personnel!</b>		

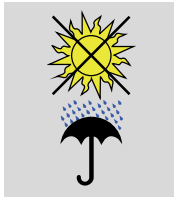

### Do not install devices in any of the following place:

- where the units are permanently exposed to direct sunlight.
- near any heat sources and open fire. Do not put candles etc. on top of the unit.
- where the airflow for cooling is blocked.
- where it is exposed to high moisture.
- where it is exposed to strong vibrations and dust.



### Power Supply

Before connecting the AC power cable of the unit, please check if the available voltage is compatible with the operating voltage as indicated on the unit. If this is not the case, then the unit needs to be adapted by the manufacturer or an authorized service centre. If the unit is not compatible with the available voltage, it should never be connected! This could irreparably ruin the unit.

Make sure that the power outlet supplies a ground connector, which must be connected to the unit via the PE conductor of the power cord!

### Protection of electrical cables

Power cords should be laid in such a way that they are protected against footstep damages, tensile strain and against being trapped.

### Transportation

When transporting the equipment, make sure that it is protected from vibrations.

### Cleaning

The equipment should only be cleaned with a damp cloth when it is not plugged in.

### Pauses in use

The power cord should be disconnected from the power source during longer pauses in use.

### Intrusion of objects or liquids

No objects or liquids should intrude or leak into the equipment.

### Maintenance and technical service

The user should not perform any maintenance work on the equipment other than that which is described in this manual. Repairs may be executed by a qualified service technician only.

In the following cases, the unit should be serviced by an authorized technician only if:

- the power cord or the mains connectors have been damaged.
- objects or liquids have gotten into it.
- it was exposed to rain.
- it doesn't appear to be functioning properly.
- it has fallen down or the enclosure is damaged.

## 7. K&F CD 44 Digital System Controller

When using the Access System with CD 44, please refer the User's manual of the K&F CD 44 Digital System Controller.

## 8. The ACCESS Controllers

**If you have ACCESS subwoofers with Speakon connector where both drivers are connected in parallel at pins 1+ / 1- (standard connection since april 2009), they can not be used with the ACCESS controller without further ado.**

*For ACCESS subwoofers with this pin assignment we recommend operation with the digital system controller K&F CD 44 and the K&F System Rack. Please refer to the CD 44 user's manual.*

*In order to operate current ACCESS subwoofers (standard since april 2009) with the ACCESS controllers C5 / C9 / C10 and the Connector Panels CP1 / CP3 / CP1-B / CP3-B we recommend ordering subwoofer with the option 'EP5 connector instead of Speakon'. With this option you can operate ACCESS subwoofers with the ACCESS controllers and the Connector Panels according to this manual.*

Operating safety and maximum performance of the ACCESS System can only be guaranteed when used with the C5/9 or C10 Controller. We cannot offer a warranty for overload damage resulting from use with a controller aside from the ACCESS Controllers. If, despite this risk, the ACCESS System should be run with another controller, please contact us for the corresponding information.

The ACCESS Controllers optimise the sound and operating safety of an ACCESS Sound System. It assumes the role of a crossover and optimises the frequency-dependent phase response and delay times. With the use of specially tuned filters (EQ), the ACCESS Controllers optimise the ACCESS System's frequency response.

A noteworthy function of the ACCESS Controller is its special limiter technology. With other (universal) controllers, the gain of the selected power amplifiers must be known. The limiter on the ACCESS Controller, on the other hand, uses a special control circuit to determine the actual output voltage of the power amplifiers. The limiter then reduces the input level only when the power amplifier actually provides more power than the speakers can handle. The amplifier's gain and the position of the input level control for the power amplifiers are insignificant for the limiter function of the ACCESS Controllers.

### C5/9 Controller

The complete ACCESS System can be run with the C5/9 Controller. The C 5/9 is, thus, capable of providing the signals for the top speakers T5/T9 as well as for the Bass Systems B5 or B10.

### C10 Controller

The C10 Controller optimises the operations with the Bass System B10. Its possibilities for operation include a configuration switch for various uses. It frees up the reserves from the B10 for the sub-low range, thus providing a strong increase in bass performance.

Both ACCESS Controllers are compatible with the Kling & Freitag C2 Controller and with most of the Kling & Freitag speaker systems. Because of this, the user has many versatile possibilities to adjust the sound reinforcement to accommodate the needs and requirements of a wide range of uses.



**Important**

## 8.1 The ACCESS C5/9 Controller

### 8.1.1 Connectors, Controls and Displays and of the C5/9

#### Front View

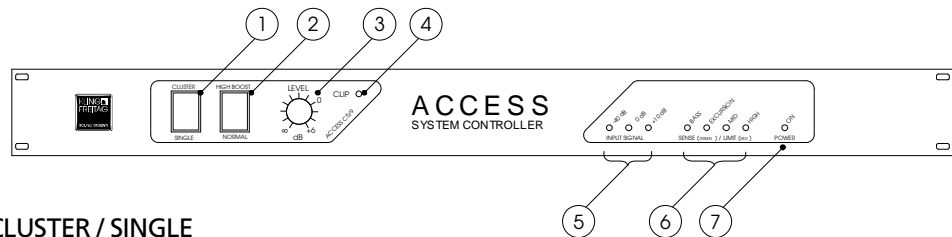

#### 1) CLUSTER / SINGLE

When using the ACCESS System in a cluster (several speakers beside one another), better coverage results may be obtained if the CLUSTER/SINGLE switch is turned to the CLUSTER position. In this operational mode the increase in sound pressure levels in the low/mid range area resulting from cluster operation is compensated, and a largely linear frequency response is achieved.

#### 2) HIGHBOOST / NORMAL

The alignment of the ACCESS top speakers T5/T9 over long distances. High frequencies are attenuated in the air over long distances. To compensate a decrease of high frequencies, the HIGHBOOST should be switched on. The position NORMAL produces a linear frequency response for short ranges.

#### 3) LEVEL

With the LEVEL control, the input level of the ACCESS Controller can be adjusted. Normally this control should be set to 0dB in order to avoid an overload of the input circuit or the outputs of the mixing console.

#### 4) CLIP

If this LED is lit up, the input of the C5/9 Controller is overloaded. Reduce the level on the mixing console until the LED light remains off even at the highest volume.

#### 5) INPUT SIGNAL

The three SIGNAL LEDs indicate the signal level. If the red LED (+10dB) lights up often or continuously, turn down the LEVEL control on the ACCESS C5/9 Controller and turn up the power amplifiers.

#### 6) SENSE (GREEN) / LIMIT (RED)

The three SENSE/LIMIT-LEDs BASS, MID and HIGH have a double function.

- The LEDs light up green when the sense cable is connected and the C5/9 Controller is receiving an output signal from the power amplifiers.
- When the relevant LED changes in colour from green to red, this indicates that the C5/9 limiter is operating. A gradually setting-in RMS limiter and a fast peak limiter limit the output power of the power amplifiers largely inaudibly down to the maximum permissible value. If the red limiter LEDs light up frequently, then the level should be slightly reduced. If necessary, the system should be supplemented with additional ACCESS speakers.
- The EXCURSION LED indicates that the excursion limiter has been started. This circuit analyses the output and frequency of the mid-range amplifier and calculates the signal for the limiter. The amplifier's signal is sent to the SENSE connector on the back side of the C5/9, which limits the output signal to the maximum permissible value.

*In exceptional cases, the Sense LEDs may still light up even when the power amplifiers are turned off or disconnected. This situation is attributed to the "microphone effect" of the speakers. If the cones are moved (i.e. from air movement of other sound sources), the speakers produce voltage which may cause the LEDs to light up.*

#### 7) POWER ON

The POWER ON LED indicates that the system controller is on and operational. If the LED does not light up after the equipment has been turned on, check the power supply or, if necessary, replace the main fuse on the rear panel of the controller.



#### Important

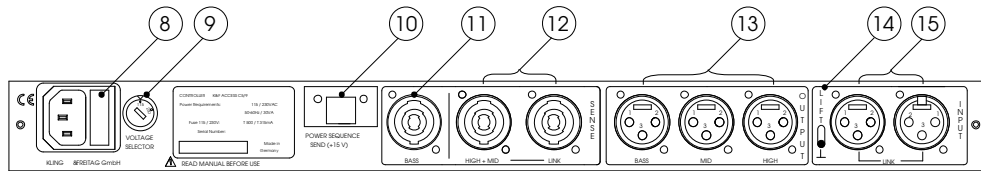

Rear View

**8) FUSE**

Fuse holder which is fitted with a 315mA medium slow glass fuse for 230V operations. With 115V operations, a 500mA medium slow glass fuse must be used. Never use a fuse with specifications different than the aforementioned values. Never bypass the fuse holder. The system controller can be irreparably ruined and/or even cause a fire.



**9) VOLTAGE SELECTOR**

This switch is used to adjust the equipment to the desired operational voltage level of 115 or 230 VAC. CAUTION: the equipment can be destroyed if the wrong operating voltage level is selected!



**10) SEQUENCE SEND**

About 1 second after switching on the ACCESS Controller, a control voltage of +15V is present at both connector pins. If, for example, you have fitted your amp rack with power amplifiers that have a remote switching feature, then connect this output with the SEQUENCE RCV input of the first amplifier, the SEQUENCE SND output of the first amplifier with the SEQUENCE RCV input of the second amplifier, etc. When turning on the ACCESS Controller, all amplifiers will then be turned on time-delayed.

**11) SENSE BASS**

The amplified output signal of the bass amplifier is connected to the pins 1- and 1+ of this Speakon 4-pin connector. This signal provides the controller with information for the bass-limiter. The ACCESS System also works without the connection from the bass amplifier to the Sense Bass, but in this case, there is no guarantee for optimal operating safety. Make sure that the Speakon connector clicks into place properly. All SENSE inputs are galvanically insulated from the amplifier with balanced transformers.



**12) SENSE HIGH + MID und LINK**

The amplified output signal of the mid-range and high amplifier is connected to one of the two Speakon connectors. Here is where the ACCESS C5/9 Controller receives and evaluates the signals. It is extremely important to ensure that the polarity is correct. The pin diagram for this is in the chapter for "Pin Diagrams of Connectors and internal Wiring". The ACCESS System is connected to the respective Speakon connector. The two connectors are connected in parallel.

**13) OUTPUT - BASS, MID und HIGH**

The electronically balanced BASS, MID and HIGH line level outputs are connected to the inputs of the corresponding amplifier. We recommend using only high-quality connecting cables from KLING & FREITAG. Bipolar shielded microphone cable with high-quality connectors should be used to connect the power amplifiers. Connecting instructions are in the chapter for "Pin Diagrams of Connectors and internal Wiring".

**14) GROUND LIFT**

If the Ground Lift switch is set on LIFT, then pin 1 of the INPUT connector is not connected to the ACCESS C5/9 Controller. There is always a connection between the INPUT (XLR male) and the LINK (XLR female) connector. If the C5/9 is operated with a K&F Connector Panel, then this switch must be set to GROUND.

**15) INPUT und INPUT-LINK**

The C5/9 Controller is equipped with a transformer balanced input. Use the XLR-female connectors (INPUT) as input. The parallel connected XLR-male connector is used to link the signal to additional ACCESS controllers or amplifiers.



**8.1.2 C5/9 Controller Technical Specifications**

<b>Input</b>	Nominal + 6 dB +20 dB maximum level 20kΩ galvanically insulated XLR connectors ( Pin 2 + )
<b>Outputs</b>	Nominal +6 dB (+1.55 V) electronically balanced XLR connectors ( Pin 2 + ) Control output + 15 Volt
<b>Gain</b>	Variable, - ∞ dB to +6 dB
<b>Sense</b>	Galvanically insulated Speakon 4-pin
<b>Dynamic range</b>	>116 dB
<b>THD ( THD+N )</b>	< 0.02%
<b>LED displays</b>	Clip Signal -40 dB, 0 dB, +10 dB Bass Sense ( GREEN ) / Limit ( RED ) Mid Excursion Limit, Sense ( GREEN ), Limit ( RED ) High Sense ( GREEN ) / Limit ( RED ) Power
<b>Switches</b>	
<b>Front</b>	Single / Cluster Normal / High Boost Level
<b>Rear</b>	Ground Lift Voltage Selector

**8.1.3 Pin Diagrams of the C5/9 Controller's In- and Outputs**

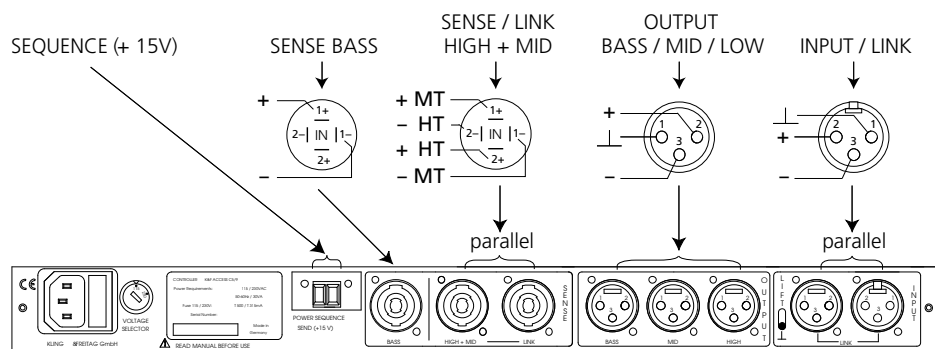

## 8.2 The ACCESS C10 Controller

### 8.2.1 Connectors, Controls and Displays and of the C10

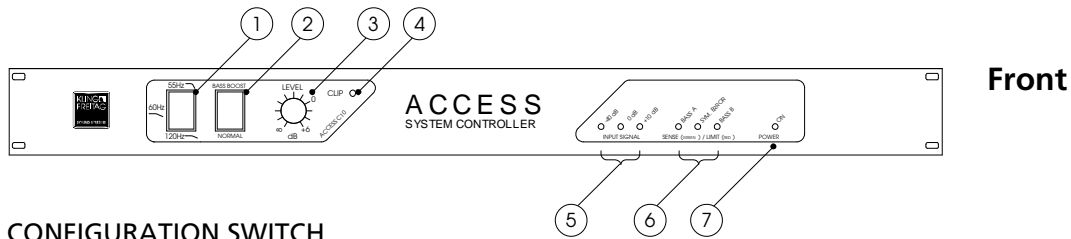

#### 1) CONFIGURATION SWITCH

When operating the ACCESS B10, this switch can be used to select the appropriate filter presets. The following switch positions are available for the low-pass:

- 55 Hz: 12 dB / octave @ 47 Hz and 12 dB / octave @ 110 Hz
- 60 Hz: 12 dB / octave
- 120 Hz: 24 dB / octave

Stickers are included with the C10 Controller that document which preset is recommended for which application. The stickers can be put on where desired (i.e. on the rack). It is important to recognize that the room and other factors can have a crucial influence on the sound results. It is, therefore, possible that the configuration recommendations may, in some individual circumstances, vary from the optimal settings. The sound engineer's ear must always make the final decision.

#### a) Operations with the C5/9 Controller:

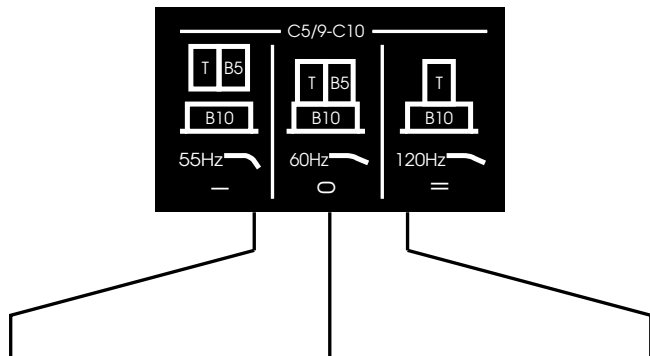

If flown ACCESS Systems T5/T9 and B5 are operated via the Controller C5/9 and the B10 via the Controller C10, the preset option 55 Hz is recommendable.

If standing ACCESS Systems T5/T9 and B5 are operated via the Controller C5/9 and the B10 via the Controller C10, the preset option 60 Hz is recommendable.

If the ACCESS Systems T5/T9 without the bass system B5 are operated via the Controller C5/9 and the B10 via the Controller C10, the preset option 120 Hz is recommendable.

## b) Operations in combination with the K&amp;F C2 Controller

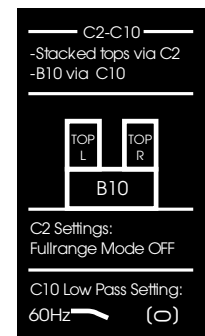
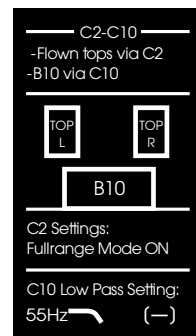
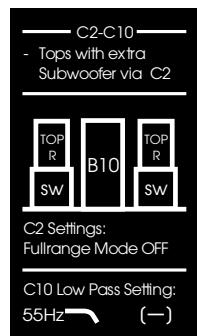

If K&F full-range systems with K&F bass systems are operated via the C2 Controller, and the B10 is operated via the C10 Controller as a supplementary bass system, then the option full-range mode 'OFF' should be selected. Generally, the configuration switch for the C10 Controller should be set at 55 Hz.

If flown K&F full-range systems are to be operated via the C2 Controller and the B10 as supplementary bass system via the C10 Controller, then the option for the C2 Full Range Mode 'ON' should be selected. The configuration switch on the C10 Controller should be set at 55 Hz.

If top speakers which are operated via the C2 Controller are put on top of the B10, and the B10 is operated via the C10 Controller, then the option on the C2 Controller full-range mode 'OFF' should be selected. The configuration switch on the C10 Controller should be set at 60 Hz.

2) **BASSBOOST / NORMAL**

If an increase of 40 Hz in the bass range is desired, then this range is increased by approx. 3 dB when this switch is selected.

3) **LEVEL**

With the LEVEL control, the input level of the ACCESS Controller can be adjusted. Normally this control should be set at 0dB in order to avoid an overload of the input circuit or the outputs of the mixing console.

4) **CLIP**

If this LED is lit up, the input of the C10 Controller is overloaded. Reduce the level on the mixing console until the LED light remains off even at the highest volume.

5) **INPUT SIGNAL**

The three SIGNAL-LEDs indicate the signal level in three steps. If the red LED (+10dB) lights up often or continuously, turn down the LEVEL control on the ACCESS C10 Controller and turn up the power amplifiers.

6) **SENSE (GRÜN) / LIMIT (ROT)**

The two SENSE/LIMIT LEDs BASS A and BASS B have a double function.

- The LEDs light up green when the sense cable is connected and the C10 Controller is receiving an output signal from the power amplifiers.
- When the relevant LED changes in colour from green to red, this indicates that the C10 limiter has started. A soft starting RMS limiter and a fast Peak limiter regulate the output of the amplifier inaudibly to the maximum admissible value. If the red limiter LED lights up frequently, then the volume should be reduced slightly; if necessary, the system should be supplemented with additional ACCESS speakers.

*In exceptional cases, the Sense LEDs may still light up even when the power amplifiers are turned off or disconnected. This situation is attributed to the "microphone effect" of the speakers.*



**Important**

*If the cones are moved (i.e. from air movement of other sound sources), the speakers produce voltage which may cause the LEDs to light up.*

- c) The SYM: ERROR-LED indicates that there is a voltage difference of at least 5V between BASS A and BASS B. This LED also lights up if there is a phase error, in other words, the phase between BASS A and BASS B is shifted by 180°. If this LED is lit up, it is necessary to check the power amplifiers and the wiring.

**7) POWER ON**

The POWER ON LED indicates that the system controller is on and operational. If the LED does not light up after the equipment has been turned on, check the power supply or, if necessary, replace the main fuse on the rear panel of the controller.

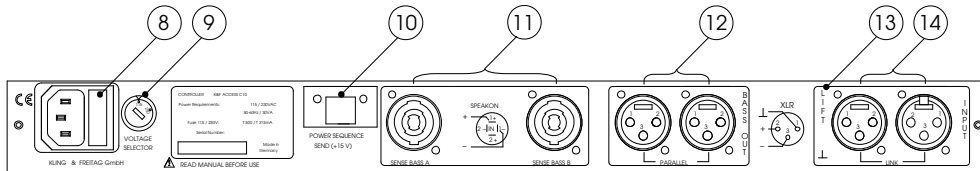

Rear

**8) FUSE**

Fuse holder which is fitted with a 315 mA slow glass fuse in 230V mode. With 115V operations, a 500mA slow glass fuse must be used. Never use a fuse with specifications different than the aforementioned values. Never bypass the fuse holder. The system controller can be irreparably ruined and/or even cause a fire.



**9) VOLTAGE SELECTOR**

This switch is used to adjust the equipment to the desired operational voltage level of 115 or 230 VAC. WARNING: the equipment can be destroyed if the wrong operating voltage level is selected!



**10) POWER SEQUENCE SEND**

About 1 second after switching on the ACCESS Controller, a control voltage of +15V is present at both connector pins. If, for example, you have fitted your amp rack with power amplifiers that have a remote control feature, then connect this output with the SEQUENCE RCV input of the first amplifier, the SEQUENCE SND output of the first amplifier with the SEQUENCE RCV input of the second amplifier, etc. When turning on the ACCESS Controller, all amplifiers will then be turned on time-delayed.

**11) SENSE INPUT BASS A / BASS B**

Two independent sense inputs, which drive a common limiter circuit. The amplified output signal of the bass amplifier is connected to the pins 1- and 1+ of this Speakon 4-pin connector. This signal provides the controller with information for the bass-limiter. Make sure that the Speakon connector clicks into place properly. All SENSE inputs are galvanically insulated from the amplifier with balanced transformers.



**12) BASS OUT**

The electronically balanced BASS line level outputs are connected to the inputs of the corresponding amplifier. We recommend using only high-quality connecting cables from KLING & FREITAG. Bipolar shielded connectors should be used to connect the power amplifiers. Connecting instructions are in the chapter "Pin Diagrams of Connectors and internal Wiring".

**13) GROUND LIFT**

If the Ground Lift switch is set on LIFT, then Pin 1 of the INPUT connector is not connected to the ACCESS C10 Controller. There is always a connection between the INPUT (XLR male) and the LINK (XLR female) connector. If the C10 is operated with a K&F Connector Panel, then this switch must be set on GROUND.

**14) INPUT**

The C10 Controller is equipped with a transformer balanced input. Use the XLR-female connectors as input. The parallel connected XLR-male connector is used to link the signal to additional ACCESS controllers or amplifiers.

**8.2.2 C10 Controller Technical Specifications**

<b>Input</b>	Nominal + 6 dB
	+20 dB maximum Level
	20kΩ galvanically insulated
	XLR connectors ( Pin 2 + )
<b>Outputs</b>	Nominal +6 dB ( +1.55 V ) electronically balanced
	XLR connectors ( Pin 2 + )
	Control output + 15 Volt
<b>Gain</b>	Variable, - ∞ dB to +6 dB
<b>Sense</b>	Galvanically insulated
	Speakon 4-pin
<b>Dynamic range</b>	>116 dB
<b>THD ( THD+N )</b>	< 0.02%
<b>LED Displays</b>	Clip
	Signal -40 dB, 0 dB, +10 dB
	Bass Sense (GREEN ) / Limit ( RED )
	Sym.Error (RED)
<b>Switches</b>	
<b>Front</b>	Low pass filter 55 Hz / 60 Hz / 110 Hz
	Normal / Bass Boost
	Level
<b>Rear</b>	Ground Lift
	Voltage Selector

**8.2.3 Pin Diagrams C10 Controller In- and Outputs**

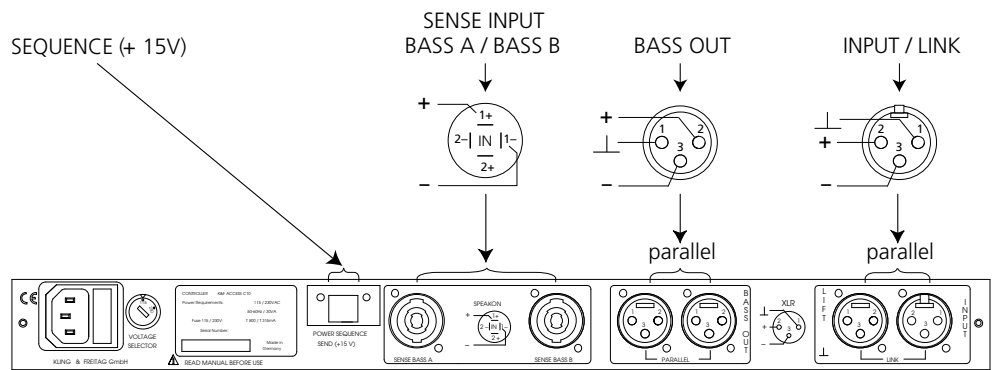

## 9. The ACCESS Connector Panels

**If you have ACCESS subwoofers with Speakon connector where both drivers are connected in parallel at pins 1+ / 1- (standard connection since april 2009), they can not be used with the ACCESS connector panel without further ado.**

*For ACCESS subwoofers with this pin assignment we recommend operation with the digital system controller K&F CD 44 and the K&F System Rack. Please refer to the CD 44 user's manual.*

*In order to operate current ACCESS subwoofers (standard since april 2009) with the ACCESS controllers C5 / C9 / C10 and the Connector Panels CP1 / CP3 / CP1-B / CP3-B we recommend ordering subwoofer with the option 'EP5 connector instead of Speakon'. With this option you can operate ACCESS subwoofers with the ACCESS controllers and the Connector Panels according to this manual.*

### 9.1 Connectors of the Connector Panels CP1 and CP3

- 1) **CP1** This model is designed to be connected to a 230 V mains supply. The model with the code number '1' is recognizable by its power supply cable with the blue plug on the front side of the equipment. (CEE 16 A, 3-pin, 230 V, 6 h)
- 2) **CP3** This model is designed to be connected to a three-phase supply current with 230 V per phase. The model with the code number '3' is recognizable by its power supply cable with the red plug on the front side of the equipment. (CEE 16 A, 5-pin, 400 V, 6 h)

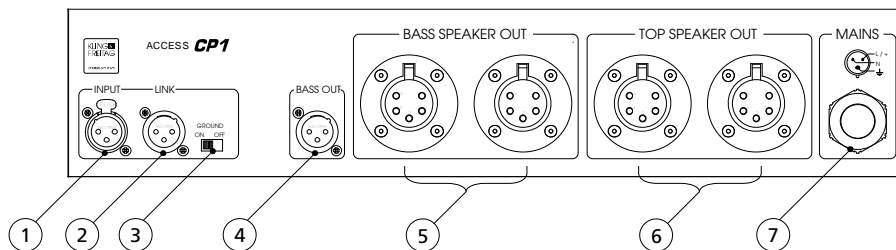

Front

- 1) **INPUT** Balanced XLR input connector (female) for the input signal (e.g. the signal from the mixing console)
- 2) **INPUT – LINK** Balanced XLR output connector (male) to link the input signal to other devices.
- 3) **GROUND LIFT** The Ground Lift switch serves to avoid ground loops. If the Ground Lift switch is set on LIFT, then the Pin 1 (ground) of the input connector is not connected to Pin 1 of the cable IN on the rear of the unit. There is always a connection between the INPUT connector (XLR-female) and the LINK connector (XLR-male).
- 4) **BASS OUT** This output provides the optional transmission of the bass signal supplied by the C5/9 Controller (LINE) to an additional power amplifier.
- 5) **BASS SPEAKER OUT** The bass speaker(s) are connected to these EP-5 connectors (female). Both connectors are wired in parallel (no stereo signal!)
- 6) **TOP SPEAKER OUT** The mid-high speaker(s) are connected to the parallel EP-5 connectors (female) (no stereo signal).
- 7) **Central Power Supply Cable**
  - 7a) The connector panel CP1 is equipped with a CEE connector 16A, 3-pin, 230V, 6h and serves as a connection to a 230V power supply. With this model, a total of max. 16A can be connected to the 6 junction boxes.
  - 7b) The connector panel CP3 is equipped with a red CEE connector 16A, 5-pin, 400V, 6h and serves as a connection to a three-phase current power supply with 230V per phase.

**Rear View**

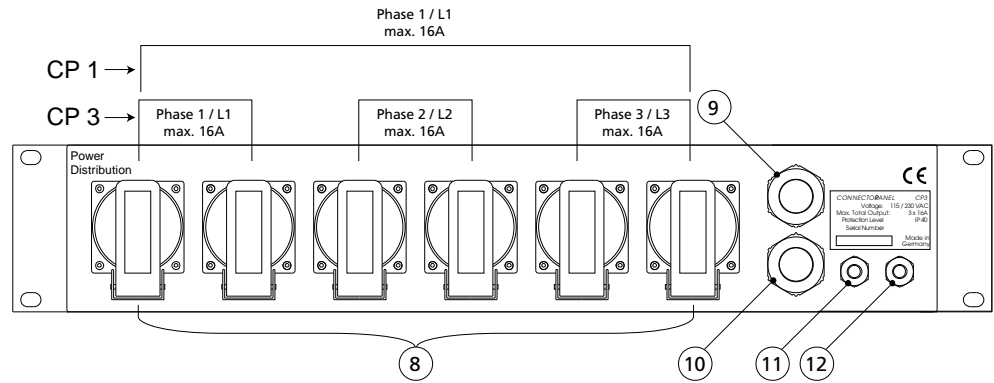

**8) JUNCTION BOXES**

Grounding sockets to receive 230V.

**8a) CP1:** With this model, a total of max. 16A (not per socket!) can be received from the 6 junction boxes.

**8b) CP3:** With this model, a total of max. 16A/phase (not per socket!) can be received from the 6 junction boxes (2 sockets/phase), that means 3 x 16A!

**9) MID-HIGH: Cable to the mid and high amplifier**

This cable supplies the amplified output signal from the mid and high frequency power amplifier. The signal is plugged into the „Sense Loop High + Mid/Low“ connector of the C5/9 System Controller and evaluated in the controller.

**10) IN: Cable to the controller's "input"**

This cable supplies the input signal (from the front side of the connector panel) to the input connector of the C5/9 Controller.

**11) BASS A / BASS B: Cable to "bass amp out"**

This cable is connected to the respective speaker output of the bass power amplifier. The signal is transmitted to the BASS SPEAKER OUT connector (see item above) on the front side of the device.

**12) TO BASS OUT: Cable to "bass amp input link"**

This cable receives the line level signal which has not been amplified but has been processed by the controller from the input connector of the bass amplifier. This signal is linked to the BASS OUT connector (see item 4 above) on the front side of the device.

**9.1.1 Connector Panel CP1 und CP3 Technical Specifications**

<b>Inputs</b>	Signal LINE: XLR	
	Speaker signal Low/Mid-High: 4-pin Speakon connector	
	Speaker signal bass: open wire	
<b>CP 1</b>	Bass LINE: open wire	
	230 V CEE 3P 1 x 16 A	
	<b>CP 3</b>	400 V CEE 5P 3 x 16 A
<b>Outputs</b>	Signal LINE Link: XLR	
	Bass LINE: XLR	
	Bass speaker: 2 X EP 5	
<b>Max. current capability</b>	Top speaker: 2 X EP 5	
	<b>CP 1</b>	Total max. 16 A from 6 grounding outlets
	<b>CP 3</b>	Total max 3 x 16 A from 3x2 grounding outlets (2 / phase)
<b>Switches</b>	Ground Lift (front)	
<b>Dimensions</b>	483 mm (19" ) x 88 mm (2U) x 325 mm ( W x H x D)	
<b>Weight</b>	<b>CP 1</b>	6.95 Kg
	<b>CP 3</b>	7.05 Kg

**9.1.2 CP1 and CP3 Pin Diagrams of In- and Outputs**

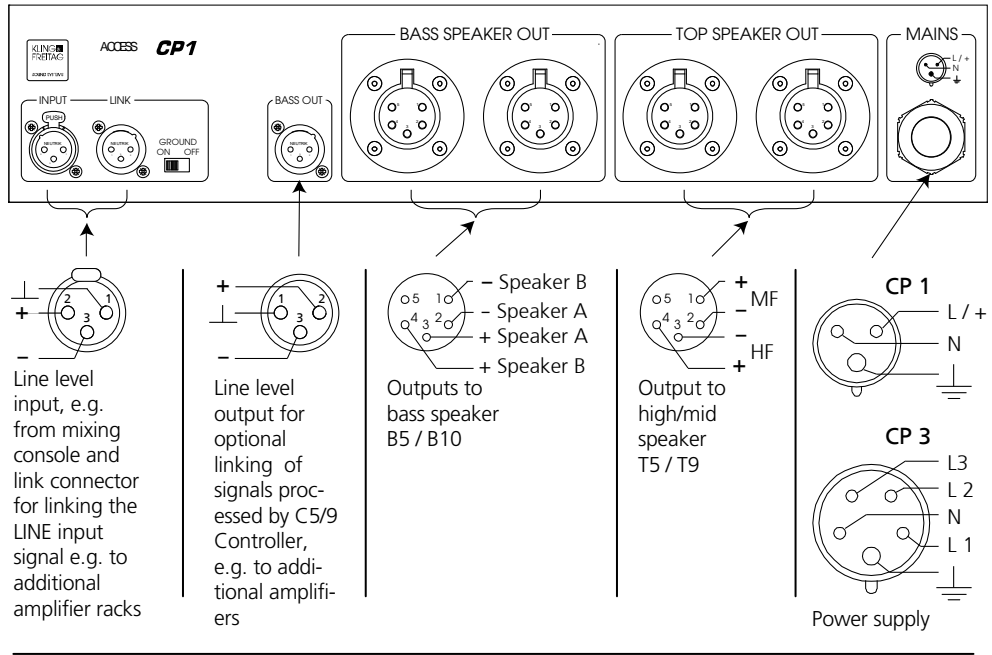

**Front**

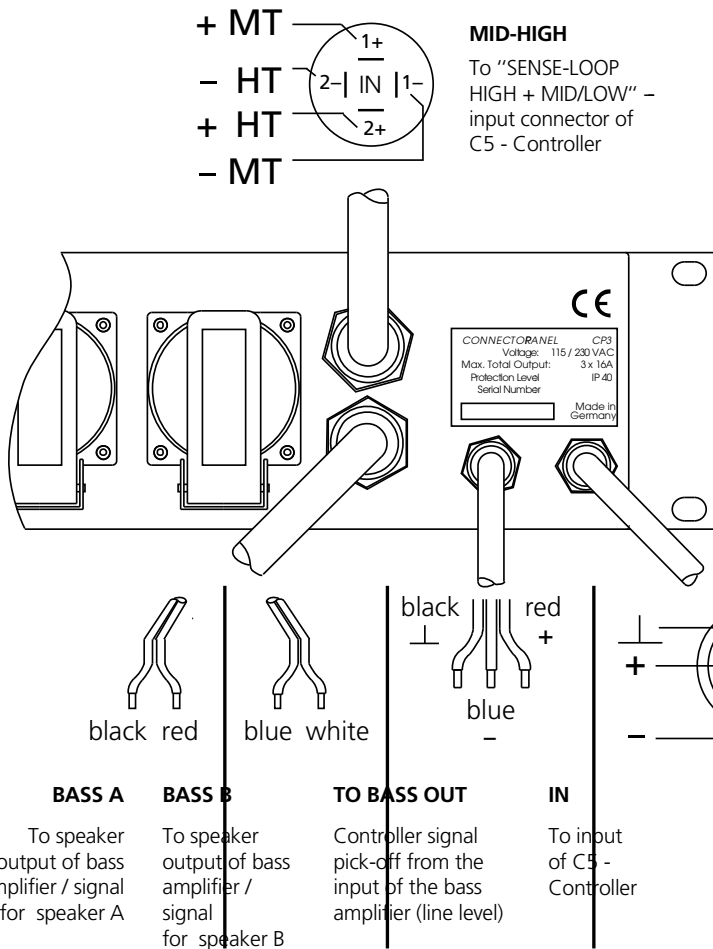

**Rear**



## 9.2 Connectors of the Bass Connector Panels CP1-B und CP3-B

### 3) CP1-B

This model is designed to be connected to a 230 V mains supply.

The model with the code number '1' is recognizable by its power supply cable with the blue plug on the front side of the equipment.

(CEE 16 A, 3-pin, 230 V, 6 h)

### 4) CP3-B

This model is designed to be connected to a three-phase supply current with 230 V per phase. The model with the code number '3' is recognizable by its power supply cable with the red plug on the front side of the equipment.

(CEE 16 A, 5- pin, 400 V, 6 h)

## Front

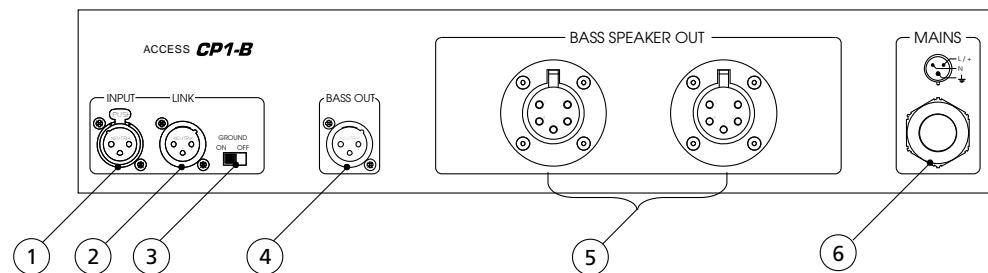

### 1) INPUT

Balanced XLR input connector (female) for the input signal (e.g. the signal from the mixing console)

### 2) INPUT – LINK

Balanced XLR output connector (male) to link the input signal to other devices

### 3) GROUND LIFT

The Ground Lift switch serves to avoid ground loops. If the Ground Lift switch is set on LIFT, then the Pin 1 (ground) of the input connector is not connected to Pin 1 of the cable IN on the rear of the unit. There is always a connection between the input connector (XLR-female) and the link connector (XLR-male).

### 4) BASS OUT

This output provides the optional transmission of the bass signal supplied by the C5/9 Controller (LINE) to an additional power amplifier.

### 5) BASS SPEAKER OUT

The bass speaker(s) are connected to these EP-5 connectors (female). Both connectors are wired in parallel (no stereo signal!)

### 6) Central Power Supply Cable

**6a)** The connector panel CP1-B is equipped with a CEE connector 16A, 3-pin, 230V, 6h and serves as a connection to a 230V mains supply. With this model, a total of max. 16A can be connected to the 6 junction boxes.

**6b)** The connector panel CP3-B is equipped with a red CEE connector 16A, 5-pin, 400V, 6h and serves as a connection to a three-phase current supply with 230V per phase. Please see also topic 7 on the next page.

**REAR VIEW**

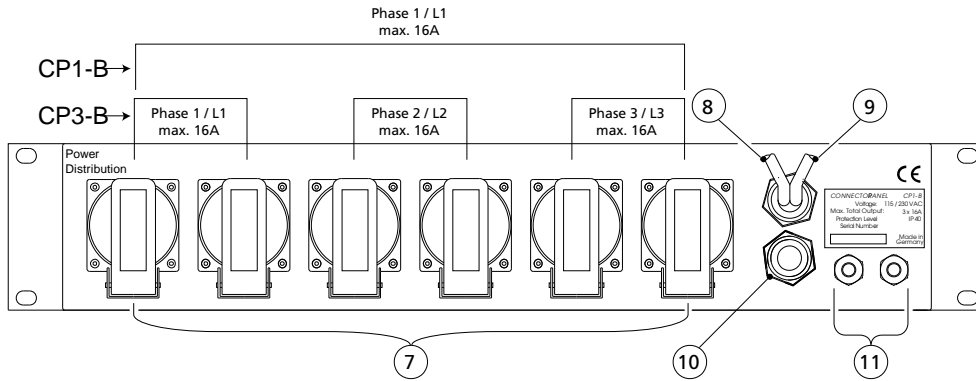

**7) JUNCTION BOXES**

Grounding sockets to receive 230V.

7a) CP 1: With this model, a total of max. 16A (not per socket!) can be received from the 6 junction boxes.

7b) CP 3: With this model, a total of max. 16A/phase (not per socket!) can be received from the 6 junction boxes (2 sockets/phase), that means 3 x 16A!

**8) TO INPUT:** Cable with XLR-male connector to the controller's "input"

This cable supplies the input signal from the front side of the connector panel to the input connector of the C10 Controller.

**9) BASS OUT:** Cable with XLR-female connector from the „BASS OUT“ connector of the C10 Controller. The signal can then be received from the BASS OUT connector at the front of the panel (4).

**10) OUTPUT BASS A / OUTPUT BASS B:** This cable is connected to the respective speaker output of the bass power amplifier. The signal is transmitted to the BASS SPEAKER OUT connector (5) on the front side of the device

**11) SENSE BASS A / SENSE BASS B:** These cables provide the signal of the power amplifier for the corresponding SENSE INPUT connectors of the C10 Controller where the signal is evaluated.



**9.2.1 Connector Panel CP1-B und CP3-B Technical Specifications**

Inputs	Signal LINE: XLR
	Speaker signal Low/Mid-High: 4-pin Speakon connector
	Speaker signal Bass: open wire
	Bass LINE: open wire
CP 1	230 V CEE 3P 1 x 16 A
CP 3	400 V CEE 5P 3 x 16 A
Outputs	Signal LINE Link: XLR
	Bass LINE: XLR
	Bass speaker: 2 X EP 5
	Top speaker: 2 X EP 5
<b>Max. current capability</b>	
CP 1	Total max. 16 A from 6 grounding outlets
CP 3	Total max 3 x 16 A from 3x2 grounding outlets (2 / phase)
Switches	Ground Lift (front)
Dimensions	483 mm (19" ) x 88 mm (2U) x 325 mm (W x H x D)
<b>Weight</b>	
CP 1	6.95 kg
CP 3	7.05 kg

**9.2.2 CP1-B and CP3-B Pin Diagrams of In- and Outputs**

**Front**

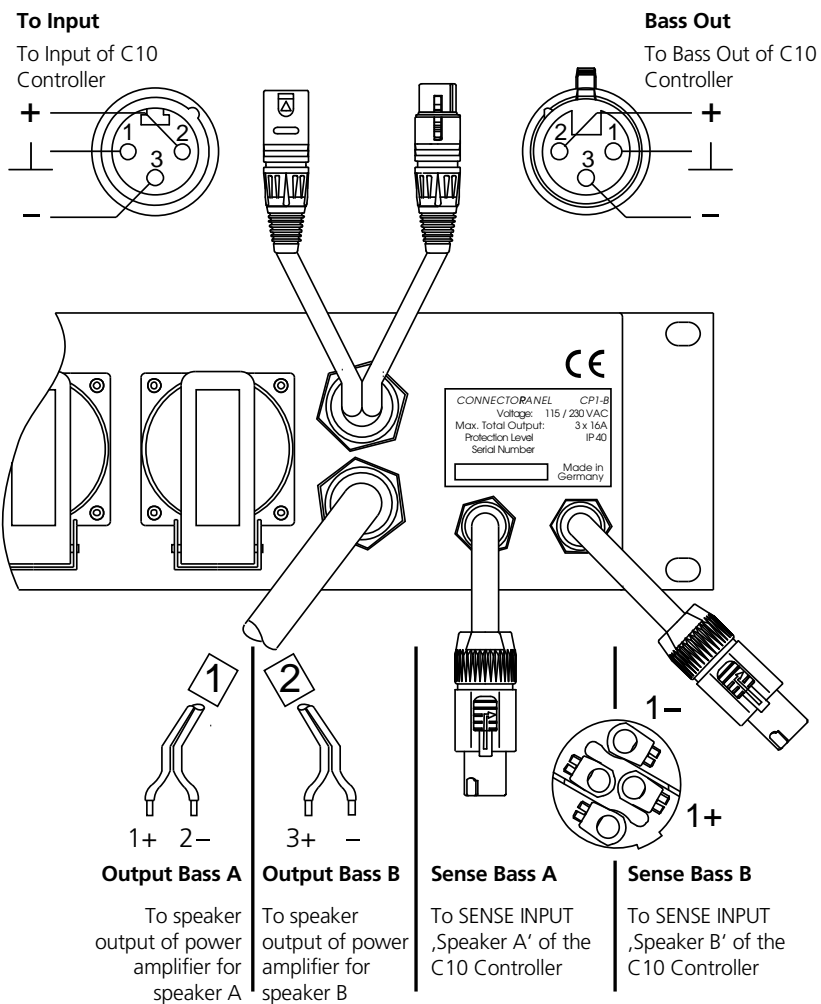
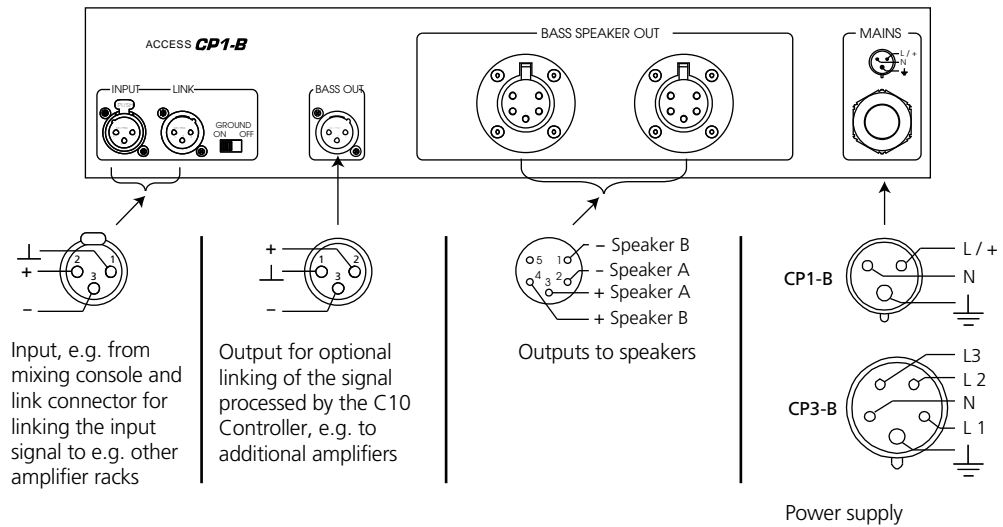

## 10. Connecting Instructions for the ACCESS System

### 10.1 Wiring

The speaker is equipped with two parallel EP-5 or with Speakon NL4 connectors. Make sure that all units are switched off and all controls are turned down before connecting your ACCESS system.

- We recommend the use of high-quality speaker cables provided by Kling & Freitag.
- For connections to the power amplifier inputs, please use 2-pin shielded microphone cable with high-quality connectors.
- Avoid ground loops (see next chapter)
- Please pay attention to the respective pin diagrams in this manual!
- To ensure an in-phase operation and, consequently, a homogeneous sound, make sure that the +/- polarity of the speakers at the amplifier is correct.
- When simultaneously using power amplifiers from different manufacturers, be sure to use the correct specific pin configuration. It may be necessary to modify the pin configuration on the power amplifiers or on the connectors leading to them.
- -To avoid loss of power, the cables should have a minimum wire gauge of 2.5 mm<sup>2</sup> - more for longer cabled distances. A minimum wire gauge can be easily calculated with the following formula:

$$\text{Minimum Wire Gauge (mm}^2\text{)} = \frac{\text{Required Cable Length (m)}}{2 \times \text{Speaker Impedance } (\Omega)}$$

**Make sure that the EP-5-'Male' socket with the exposed contacts (male) is used as input to avoid physical contact with dangerous currents!**

If several loudspeakers are connected, the signal can be linked through from one loudspeaker to the next. Please make sure that the total impedance of the loudspeakers R(Ω) is not lower than the minimal impedance indicated on the power amplifier.

$$1/R_1 + 1/R_2 + 1/R_3 + \dots = 1/R_{\text{total}}$$



## 10.2 Avoiding Ground Loops

### 10.2.1 What is a Ground Loop?

Every component of a P.A. or Hi-Fi system has its own internal 0 V reference (ground). This point is often connected to the protective earth connector (PE / Ground). If two or more units are connected to one another with a line level audio cable, there may be a ground connection through the ground of the power supply cable (yellow-green) as well as through the shielding of the audio cable. The voltage difference between these two ground points causes audible interference to come from the speaker.

### 10.2.2 Avoiding Ground Loops

If there is a loud humming or buzzing after the ACCESS system has been connected, then check that a "ground loop" has not been built into the system. Some power amplifiers and system controllers are equipped with a "Ground Lift" switch. Set these switches to the "Lift" position one after the other. If the noise is still audible, check if,

1. the noise is caused by a ground loop before the power amplifiers / controllers (e.g. mixing console, effects or equalizers).
2. the system or parts of the system are connected to an "unclean" power supply - meaning one, which is also running large motors, or lighting systems. An "unclean" supply voltage, electrostatic and electromagnetic fields can cause a malfunction.

#### **Please observe the following basic rules:**

- **Never!!! try to avoid a ground loop by disconnecting or taping the ground contact at the power connector! Extremely dangerous!**
- If possible, only use high-quality audio appliances with balanced signal outputs and with power cables with PE connectors.
- Use high-quality cables with good shielding
- The point of ground for all connected components should merge at one central point. The power connections should lead out in a radial manner from one point and not be linked from one unit to the next.
- When installing appliances that create strong electrostatic or electromagnetic fields (large transformers, switch-mode power supplies), maintain some distance from other audio appliances. In extreme cases, the only solution is to create a completely independent 'audio ground'; in other cases, it is sufficient to connect a filter in front of the audio equipment.



**Important**



**Warning**



**Important**

## 11. Recommended Amplifier Performance for the ACCESS System

An audio system is expected to transmit dynamic signals and peaks without distortion. This needs to be considered when determining if a power amplifier is adequate for a speaker system. Possible peak power levels of an amplifier are more relevant in this consideration than the RMS power (continuous power output, root mean square value) generally provided by the manufacture.

Unfortunately, an amplifier's RMS power is no indication for its specific peak power. The difference between peak and RMS power is, however, generally lower with operations with high impedance load than with low impedance operations.

Because of this, we also specify a recommended peak power (10ms/1kHz) in addition to the usual RMS power recommendation. This peak power can be calculated or provided by the manufacturer of the respective equipment.

### 1. 1 Power Amplifier for 1 x T5 / T9:

2 x 700-900 W RMS (1000 W peak) / 4Ω

1 x Controller K&F C5/9

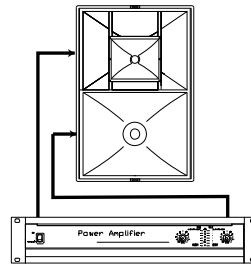

### 2. 1 Power Amplifier for 2 x T5 / T9:

2 x 1100-1500 W RMS (2000 W peak) / 2Ω

1 x Controller K&F C5/9

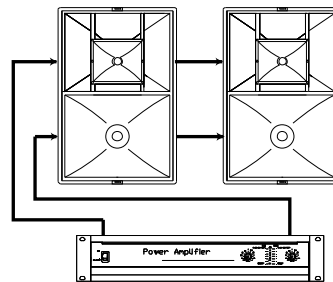

### 3. 1 Power Amplifier for 2 x mid channel:

2 x 700-900 W RMS (1000 W peak) / 4Ω

1 Power Amplifier for 2 x high channel:

2 x 200-250 W RMS (250 W peak) / 8Ω

2 x Controller K&F C5/9

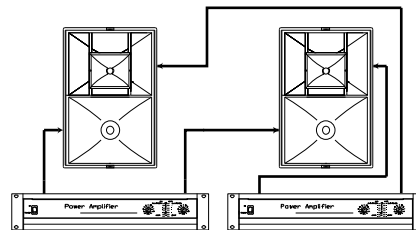

### 4. 1 Power Amplifier for 1 x B5:

2 x 700-800 W RMS (850 W peak) / 8Ω

1 x Controller K&F C5/9

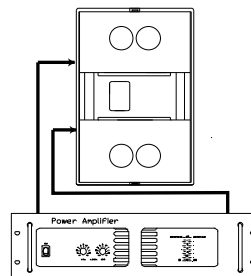

**5. 1 Power Amplifier for 2 x B5:**

2 x 1200-1400 W RMS (1700 W peak) / 4Ω

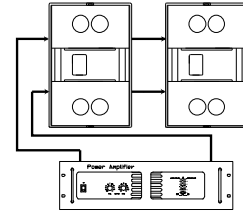
**1 x Controller K&F C5/9****6. 1 Power Amplifier for 1 x B10:**

2 x 700-1000 W RMS (1000 W peak) / 8Ω

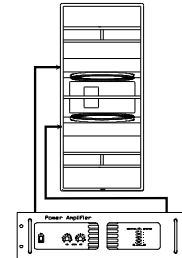
**1 x Controller K&F C5/9****7. 1 Power Amplifier for 2 x B10:**

2 x 1200-1600 W RMS (2000 W peak) / 4Ω

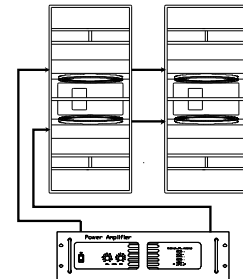
**1 x Controller K&F C5/9****11.1 Correct Bass and Top Speaker Ratio**

When making adjustments on the power amplifier, it is extremely important that the volume levels for the top speakers T5/T9 and the amplifiers for the bass systems are correct.

The C5/9 Controller is designed so that when a top speaker T5/T9 and two bass speakers B5 are combined, the power amplifier's gain for the tops should be approx. 3dB lower than the gain of a bass power amplifier in stereo- and dual-mono operations (with level controls at maximum).

This ratio can change with other configurations. One reason for this is the different dispersion coverage of bass and mid/high speakers. When the number of basses is doubled, the volume of basses set up next to each other can increase by max. +6dB (+3dB efficiency and +3dB from doubling the amplifier's power). The level of the tops does not increase in this manner because of the directivity.

The position of a bass speaker has a large influence on the actual volume. A bass speaker on the floor can be a few decibels louder than a flown bass system because of floor reflections. Because of this, the sound engineer must always do some fine-tuning on the amplifier controls (not on the mixing console!) when tuning the system.

The gain of the power amplifier is generally found in the user's manual.

**Customized adjustment of the C5/9 Controller to individual power amplifiers**

If the C5/9 Controller should be customized to the particular amplifiers with which it will be used, please contact KLING & FREITAG GmbH. We would be happy to adjust the C5/9 Controller to meet your individual needs. In doing so, it would generally no longer be necessary for the owner to make further adjustments on the power amplifiers when using the standard configuration 1 x T5 or T9 and 2 x B5.

## 12. Mounting Instructions for Loudspeakers

Mount the speakers securely. To avoid injury or damage, always be sure to mount the speakers securely so that they do not fall. Speakers, which are stacked, must be secured with securing straps. When laying the connecting cables, make sure that no-body can trip.

The stability of stacked systems (also valid for the use of stands and distance rods!) is contingent upon the following stability requirement. These conditions must, therefore, be guaranteed by the user:

**Stacked systems may not fall over even if they are inclined by 10° in each direction. If this requirement is not fulfilled, then it is necessary to take steps to achieve compliance. Possible measures include strapping it to an appropriate base structure or fastening it using safety straps.**

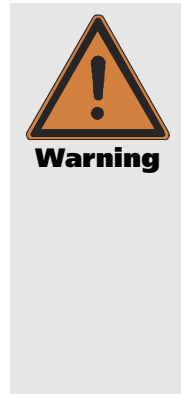



## 12.1 Mounting and Stacking the ACCESS Systems

1.)



Reach into the speaker's butterfly handles...

2.)



...and turn the speaker onto its lower edge.

3.)



Lean the speaker farther forward and press your body weight against it so that the speaker does not suddenly fall forward.

4.)



Lift up the next speaker with a second person, as illustrated. Make sure to lift from your knees and not your back.

5.)



Set the bottom side of the speaker on the back edge of the bottom speaker. Put the speaker up on top with a sweeping movement of the arm.









6.)



Shove the speaker into the correct position so that the stacking feet fit on top of the grooves of the lower speaker. **Secure the speaker additionally with a securing strap.**

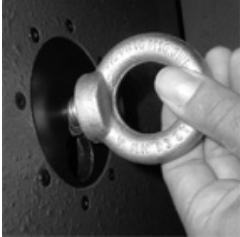

## 12.2 Using the MAN Rigging Points

 <p><b>Eyebolt MAN installation stud.</b> To be used with fixed installations. <i>No additional speakers may be suspended from the eyebolt MAN installation stud.</i></p>	 <p><b>Eye bolt MAN stud plate (HWSP)</b> To be used with mobile installations.</p>
<p>1.)</p>  <p>Loosen all but the last two threads of the stud's nut. Put the eyebolt in the speaker's receptacle so that the tip of the nut points down.</p>	<p>1.)</p>  <p>Pull up the eyebolt's locking device with the thumb and index finger and put the eyebolt into the speaker's receptacle.</p>
<p>2.)</p>  <p>Pull up the eyebolt and screw it in tightly. Then loosen the eyebolt by maximal 1/2 turn so that it cannot be tightened all the way when the speaker is tilted.</p>	<p>2.)</p>  <p>Pull up the eyebolt while pulling on the locking device. Then let go of the locking device.</p>
<p>3.)</p>  <p>Make sure that the eyebolt is stable and that it cannot be pulled down.</p>	<p>3.)</p>  <p>Make sure that the eyebolt is stable and that it cannot be pulled down.</p>
<p>4.)</p> <p>When using chains, make sure that the openings of the hooks are always turned toward the front side of the speaker.</p>	 <p>Lautsprecher-Vorderseite</p>



**Warning**

### 13. Operating the ACCESS SYSTEM

- Make sure to observe the instruction in the loudspeaker's manual as well as in the included safety and mounting Instructions for loudspeakers and accessories.
- Switch off all equipment and turn off all controls.
- Wire the ACCESS System according to the pin diagrams as shown before.
- Now switch on the peripheral equipment first (mixing console, effects etc.), followed by the ACCESS Controller and the power amplifiers. Always use the before mentioned switching order. Otherwise switching noises may damage the system.
- If there is interference, turn off all appliances in the reverse order and check all cable connections.
- Turn up the input controls of the amplifiers. If there is interference, turn off all appliances in the reverse order and check all cable connections.
- Next, turn on the ACCESS Controller and the other peripheral equipment and make sure there is no interference.
- Now put a low level signal into the system and check for the correct function of the ACCESS System. In doing so, all amplifier input controls need to be turned off again. Turn on the control for the left high channel and check that the correct high signal is coming out of the high chassis in the left speaker. The Sense LED for the high channel of the respective ACCESS C5 Controller will light up green at a level of at least  $-40\text{dB}$ . If the wrong LED lights up or a wrong (i.e. high signal from a bass speaker) or distorted signal occurs, then there is a mistake in the wiring.
- The system is now ready to operate. The power amplifiers can now be turned on all the way (see also LEVEL). Use the LEVEL control on the ACCESS Controller to set the level of the ACCESS System to the desired setting.
- The levels on the mixing console can now be turned up. When turning off the system, the input controls for the power amplifiers should be switched off first followed by the amplifiers. After that, the other appliances can be turned off.



**Important**



**Important**

## 14. Connection Diagrams

### 14.1 ACCESS System with Controller C5/9 and CP1/3

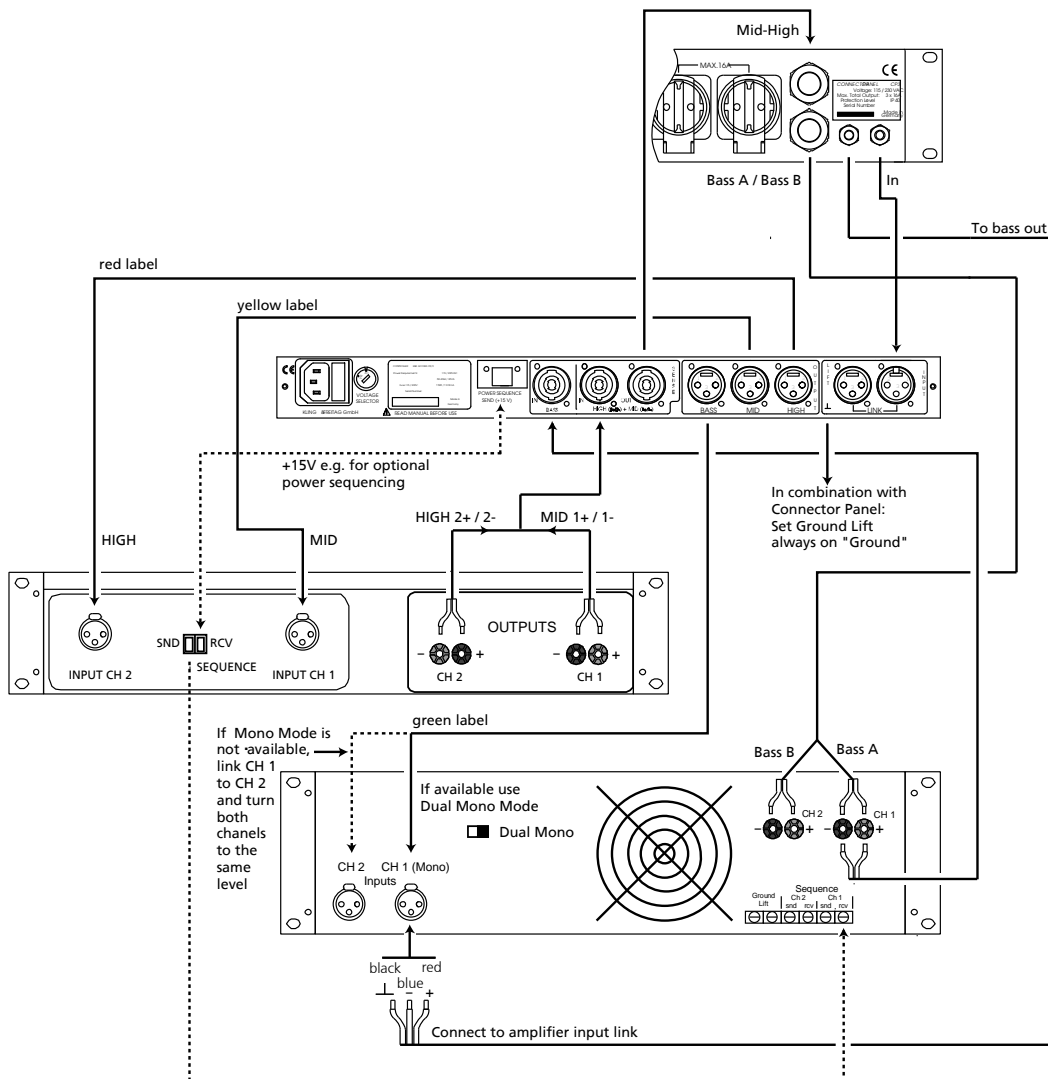
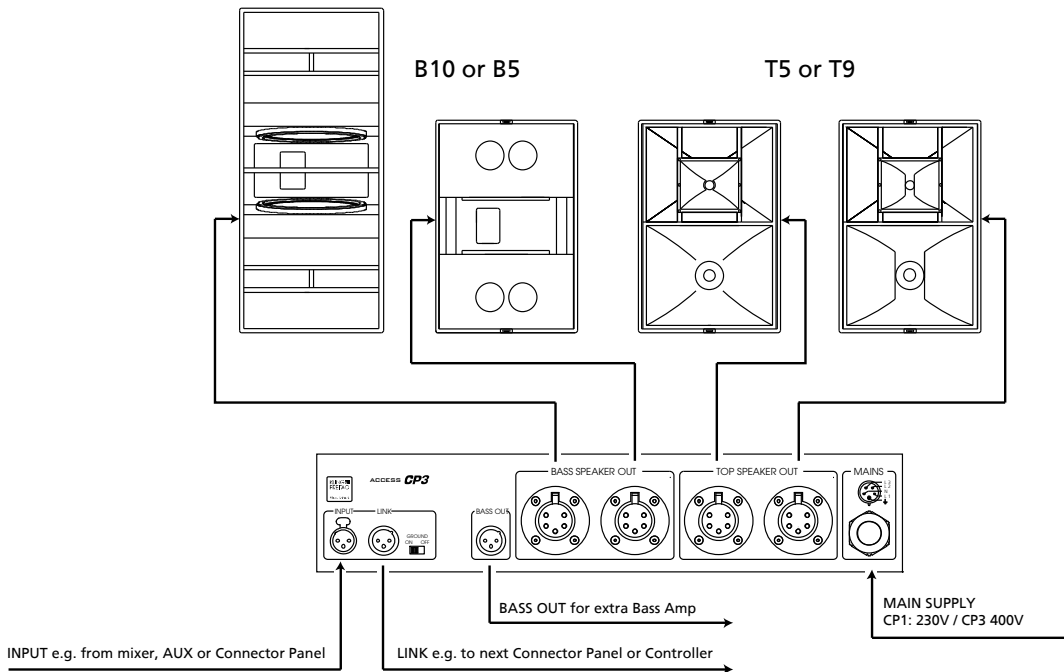

**14.2 ACCESS System with Controller C5/9, no Connector Panel**

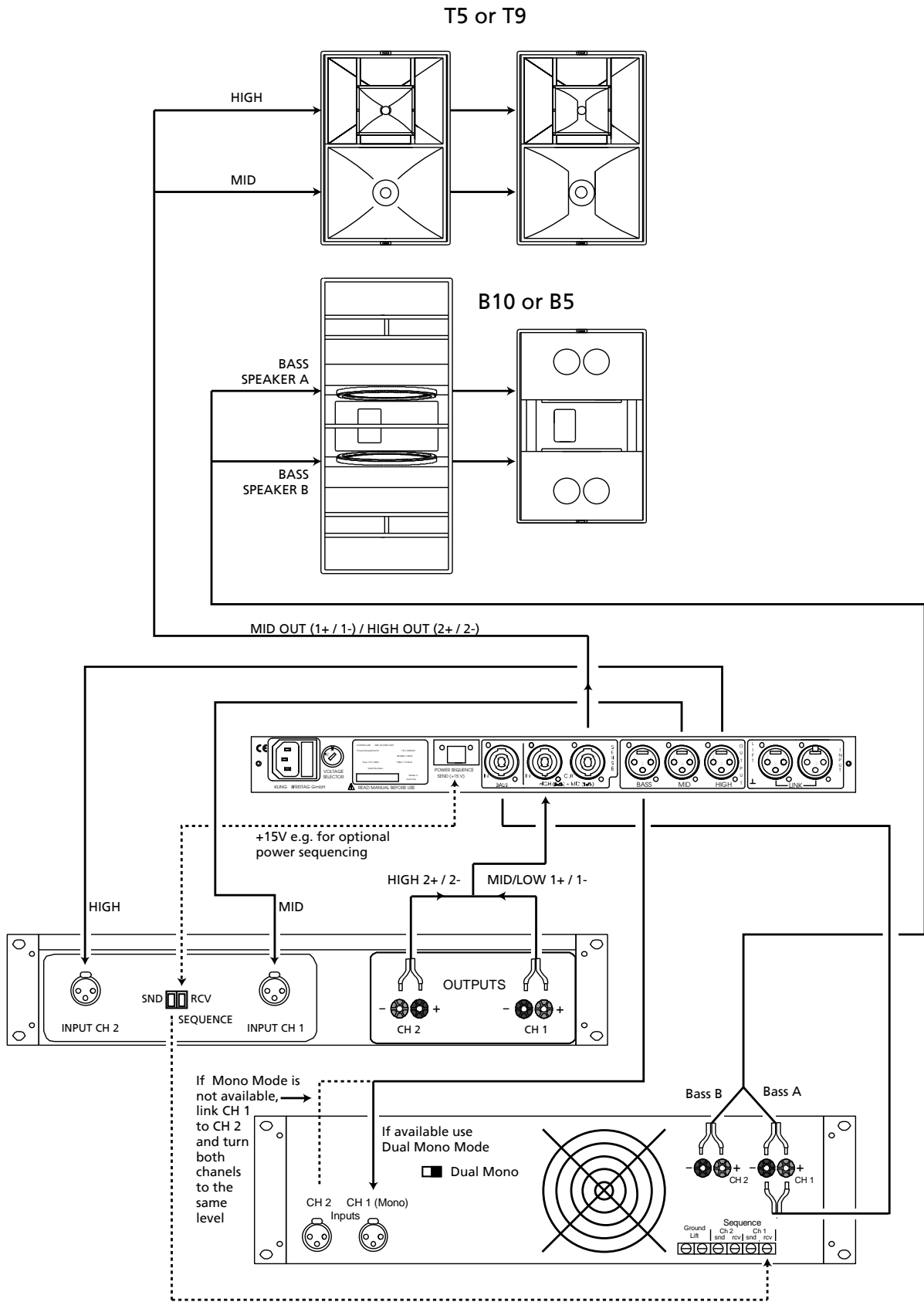

**14.3 Optimised Operations with B10, C10 and CP1/3-B**

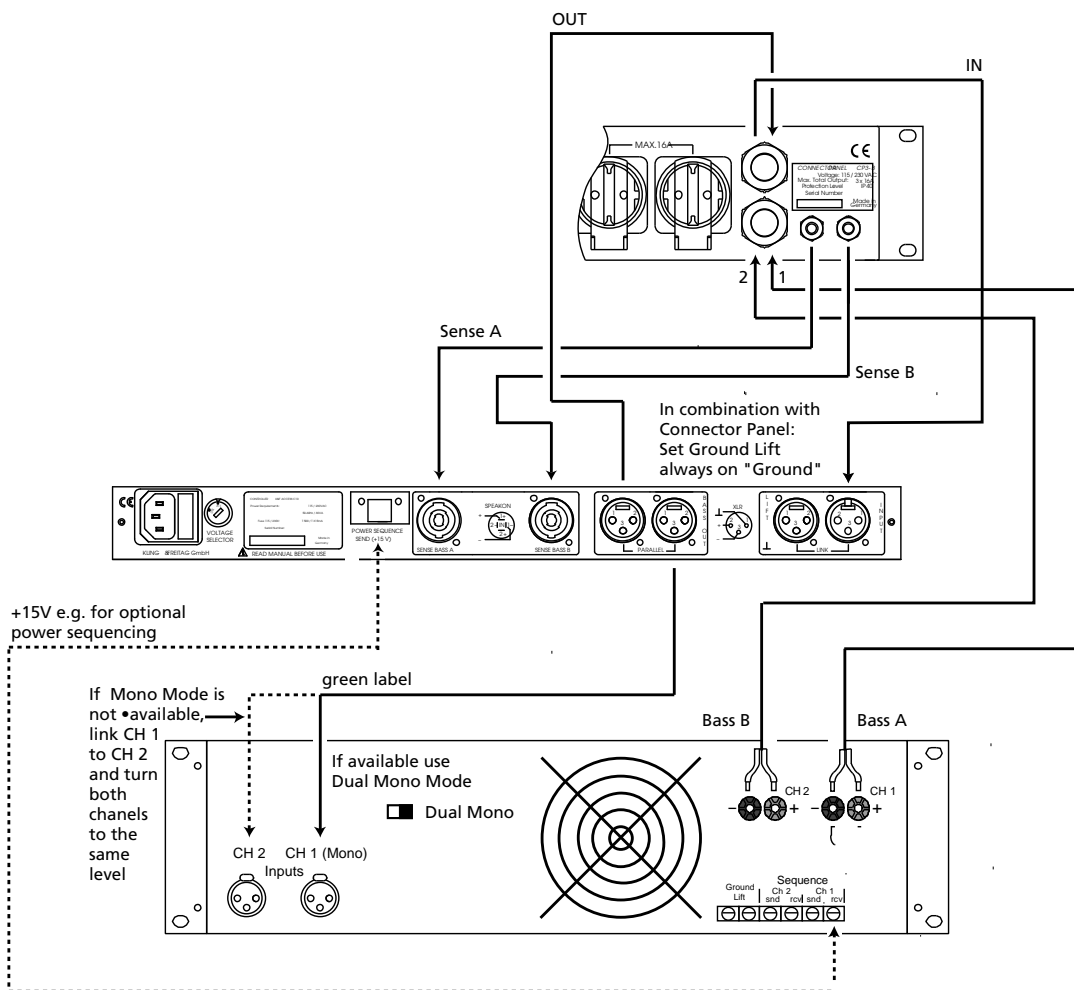
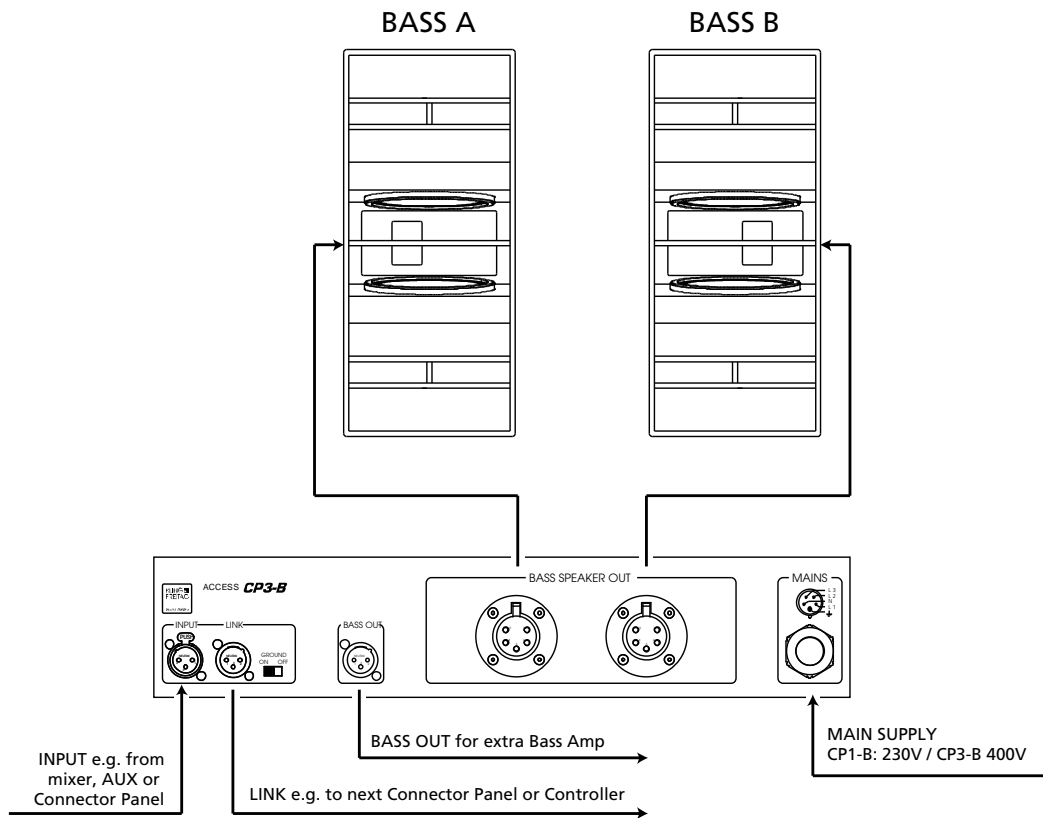

### 14.4 Optimised Operations with B10, C10 without CP1/3-B

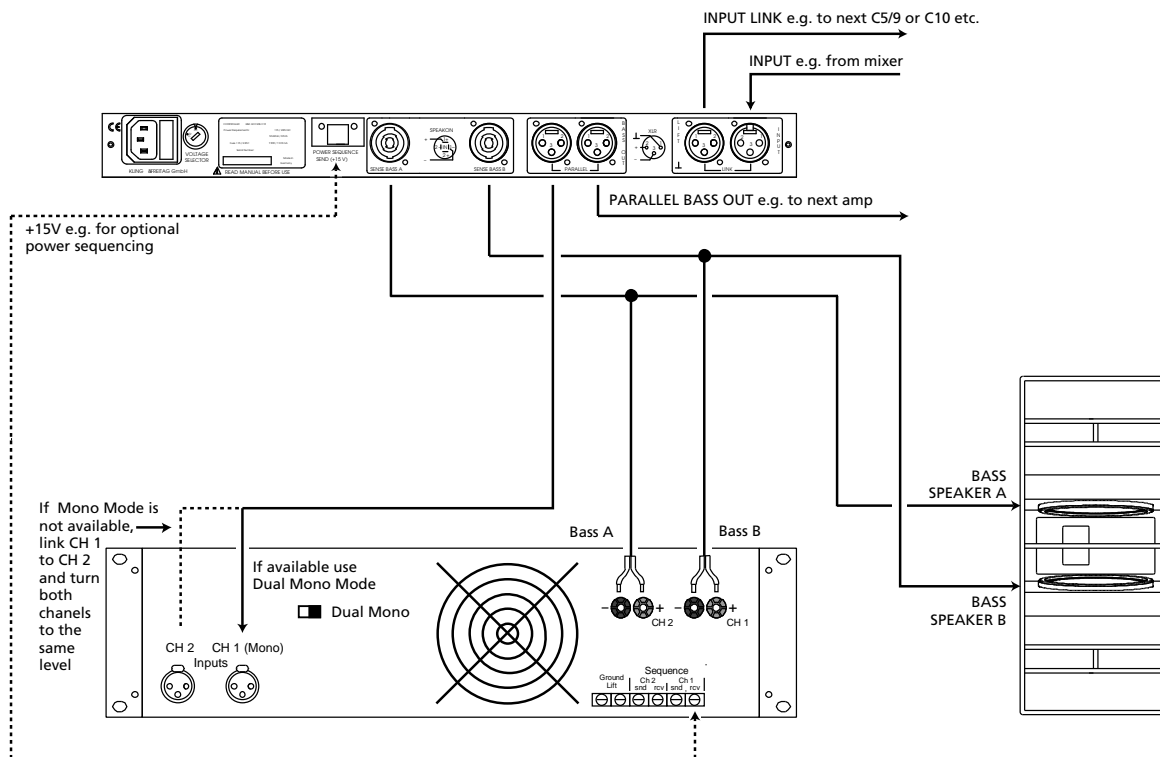

### 15. Sound Pressure Dispersion of Mid-High Systems T5 & T9

Be aware of the fact that the logical targeted alignment of this high quality speaker system can lead to a significant qualitative increase in the acoustic result. It is not possible to make generalities about the alignment of specific systems because the room has a substantial influence on the signal and the audible result.

To simulate the correct alignment of the speakers beforehand, there are various programs such as "Ease", "Ulysses" or "CADP 2". The Kling & Freitag speaker system data for downloads is available on our homepage "www.kling-freitag.de".

The following graphics will assist in making a rough estimate as to the level distribution of the ACCESS System's mid/high systems. The graphics only take into consideration the sum of the direct sound and not the influence of the room. The listening level is at 1.2 m. Because of this there can, in some cases, be noticeable deviation.

#### 1 x T5: SPL Peak 143 dB (1W/1m) direct sound level



#### 1 x T9: SPL Peak 139 dB (1W/1m) direct sound level



#### Graphic illustration of the dispersion coverage of ACCESS T5 and T9 (4 kHz)

Based on the graphics shown here, it is clear that the more narrowly distributing system T5 carries more acoustic pressure at the bottom than the broadly dispersed ACCESS T9. The horizontal sound distribution of the T5 loudspeaker, especially in the near field, is not as homogeneous as with the T9 system. The T9 system has a more gradual sound dispersion. These varying properties can be taken advantage of and combined for specific uses.

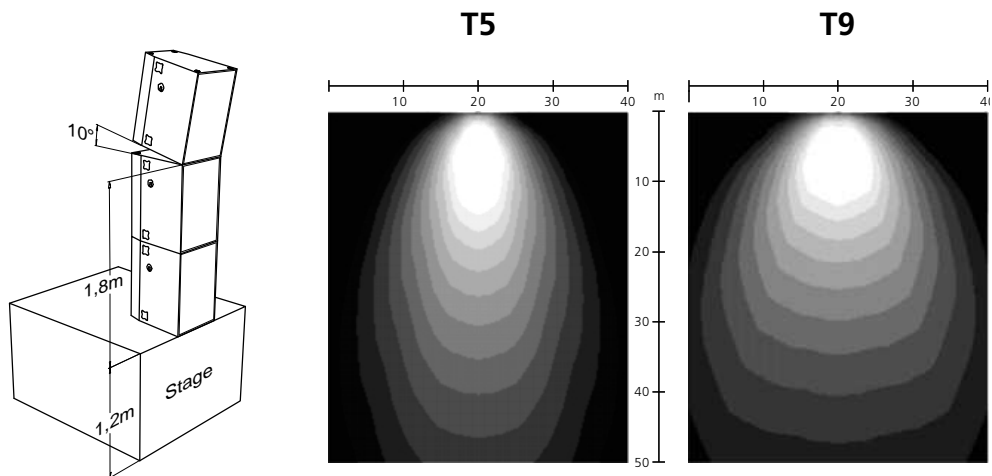



### 15.1 Sound Pressure Dispersion of combined Mid-High Systems

#### Illustration of coverage pattern 2 x T5 (4 kHz)

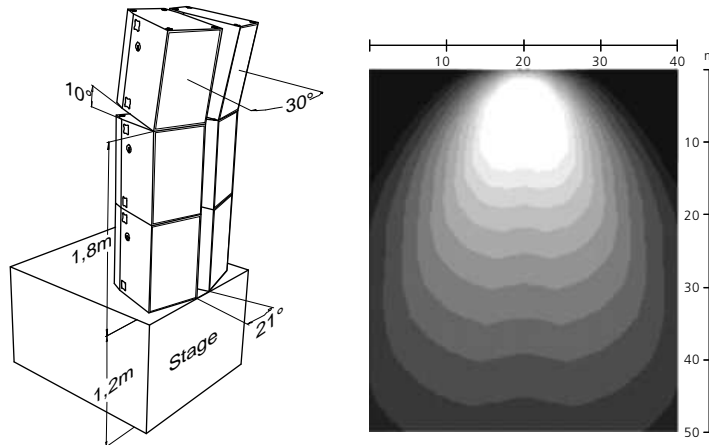

With the combination 2 x T5, it is possible to increase the horizontal coverage as compared to the individual system while still achieving the far-reaching sound pressure level of the T5 System. This combination is suited as i.e. a central cluster.

#### Illustration of coverage pattern 1 x T5 and 1 x T9 (4 kHz)

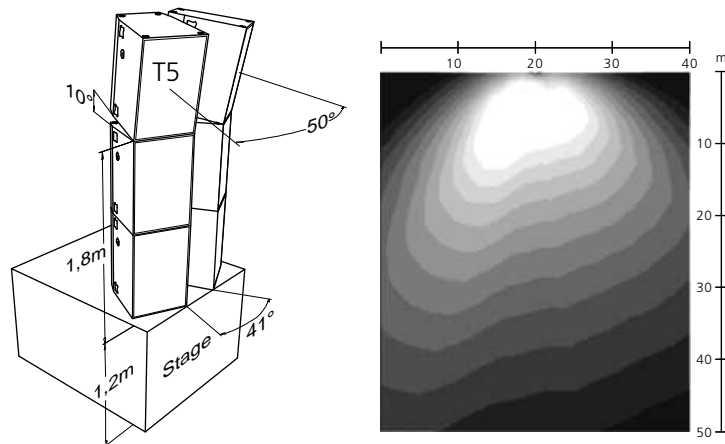

With the combination 1 x T5 and 1 x T9, it is possible to increase the horizontal coverage even more. This combination is well suited for the coverage of a room from two outer edges of the stage. From the front edge of the stage to the far end of a room it is possible to achieve a very constant distribution of sound pressure (distance of both systems max. 15 m, T9 System in the middle)

#### Illustration of coverage pattern 2 x T9 (4 kHz)

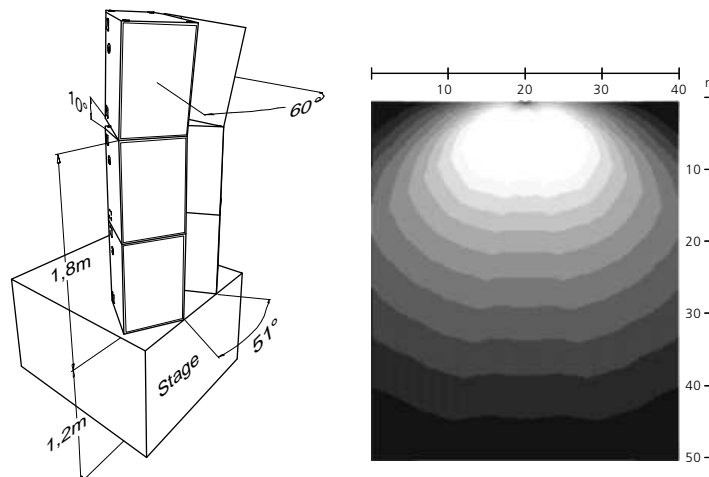

2 T9 Systems should be set up side by side only when large angles (<100°) are to be acoustically covered.

## 15.2 Sound Pressure Dispersion in Relation to the Position

It is often appropriate to use a flying speaker system because the sound can disperse more evenly throughout the room. Systems, which are set-up on the ground, lead to stronger volume differences between the front and rear listeners than with a flown system. This is shown in the illustration of the different system set-ups. (here 2 x T5)

2 x T5 on two bass systems.

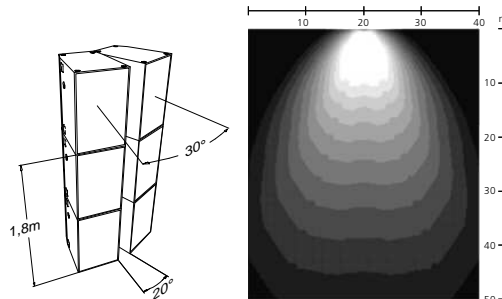

The high-mid system has the necessary base height (always above face level) to irradiate an event with a standing audience. The difference in loudness level between the front and rear seats is relatively large. This form of "stacking" is, therefore, better suited for smaller rooms or dance floors in clubs.

2 x T5 on stage and two bass systems.

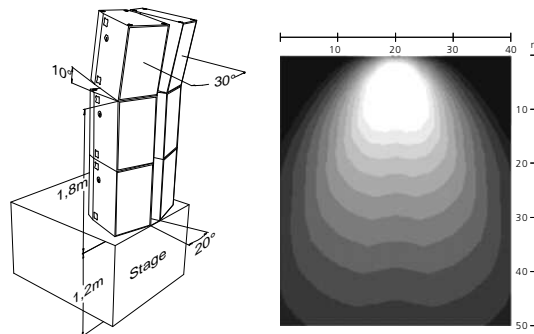

The additional stage height and the slight tilt of the high-mid systems make it possible to reduce the sound level difference between the front and rear seats. If feasible, this version is preferable to the previously described version (especially in mid-sized rooms).

2 x T5 flown and tilted.

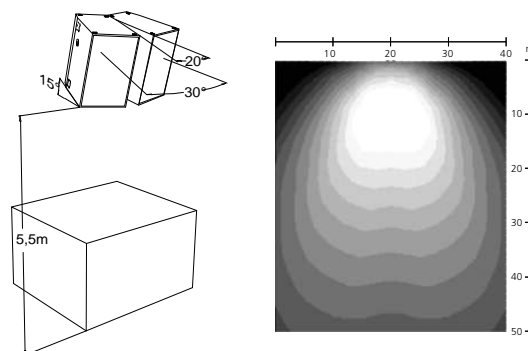

Because of the tilt and height of the high-mid systems it is possible to achieve the most even distribution of sound with the lowest sound level difference between the front and rear sets. This version should, if feasible, always be used when there is a large audience area to be covered.

## 16. Basic Rules for the Alignment of the ACCESS Systems

If several ACCESS systems should be combined, the following rules should be followed; with this, for example, also the correct horizontal alignment of several systems set up side by side.

- The ACCESS mid-high systems should be set up horizontally by using only the following angles to one another:

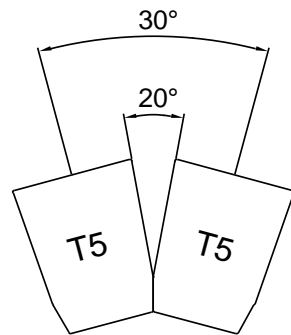

**Hor. alignment T5/T5:**  
 Optimal: 30°  
 Minimum: 10°  
 Maximum: 30°

The ideal alignment of two clustered T5 Systems is achieved via the rear enclosure angle of the speakers. If the enclosures are placed next to each other, then there is a coverage of 30°, as shown above.

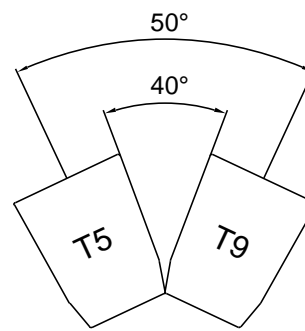

**Hor. alignment T5/T9:**  
 Optimal: 50°  
 Minimum: 30°  
 Maximum: 60°

If a T9 System is insufficient, then the combination of T5 to T9 functions very well and is suited for the acoustic irradiation of a room from two outer edges of a stage.

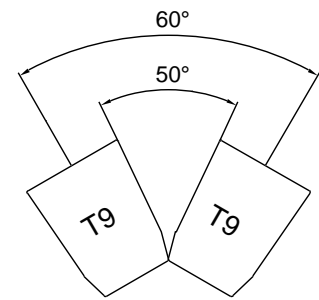

**Hor. alignment T9 /T9:**  
 Optimal: 60°  
 Minimum: 30°  
 Maximum: 70°

The combination of T9 to T9 cannot be universally recommended because there are often problems with interference in the 90° system. Consequently, it is only recommendable in special cases, i.e. when very wide angles are to be covered (>100°).

- Never set up more than 2 mid-high systems directly next to one another. Always build in a bass system:

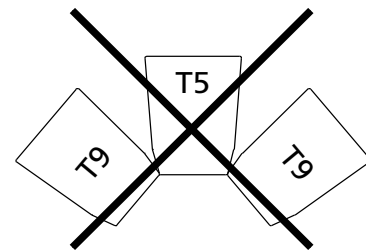
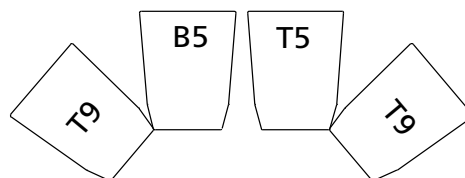

3. When clustering in several levels, make sure that the mid-high and bass systems are set up in a chequered pattern. 4 mid-high systems should never be set up directly to one another. This set-up would lead to uncontrollable interference in the low-mid range:

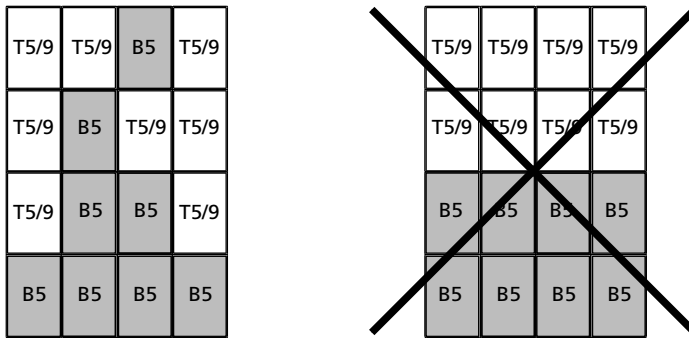

4. Always align the ACCESS System vertically so that the top speaker is aimed towards the back row of the audience. By doing so, the sound pressure will always reach as deeply as possible into the far field. As a further step in effectively covering the far field, the mid-high systems which target the furthest audience members should only be slightly tilted so that a summation of sound pressure can be achieved in the back.

When considering the near field, make sure that the front listeners are within the coverage range of the lowest mid/high system.

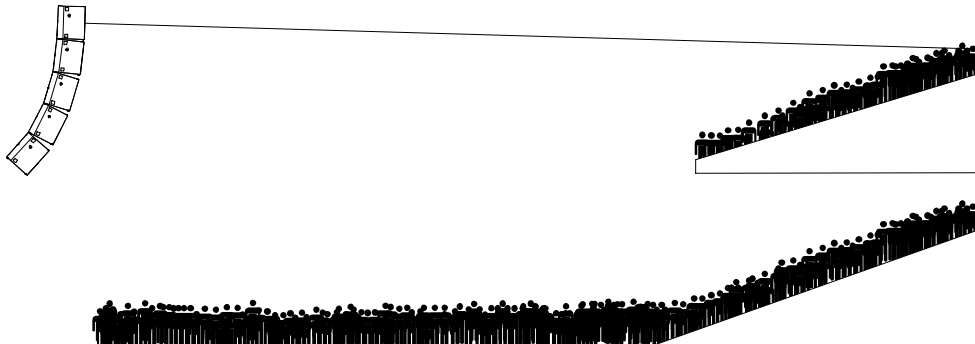

When the number of basses is doubled, the volume of clustered basses can increase by max. +6dB (+3dB efficiency and +3dB from doubling the amplifier’s power). The volume of the top speakers increases not in the same manner as described above because of the different dispersion pattern.

The position of a bass speaker has a large influence on the actual volume. A bass speaker on the floor can be a few decibels louder than a flown bass system.

For these reasons, the number of necessary bass systems can vary greatly from case to case. For large configurations, a ratio of one bass speaker B5 to one top speaker is generally necessary. For smaller uses (i.e. 1-2 tops per side), a ratio of 2 bass systems B5 to 1 top is sufficient – especially when the bass systems are flown.

## 17. Examples of Configurations and Applications

- 1. Application:** Acoustic-Jazz / Folk / Classics, speech  
**Auditorium:** approx. 800 persons, depending on the room geometry  
**Speakers / Side:** 1 x T9 / 1 x B5  
**Rec. Ampl. / Side:** T9: 1 power amplifier with 2 x 700-900 W RMS (1000 W peak) @ 4Ω  
 B5: 1 power amplifier with 2 x 700-800 W RMS / (850 W peak) @ 8Ω  
**Controller / Side:** 1 x C5/9 or similar

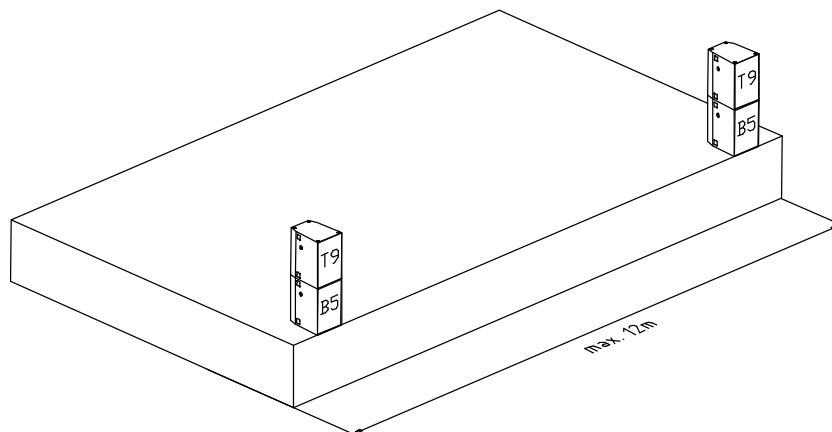

- 2. Application:** Acoustic-Jazz / Folk / Classics, speech  
**Auditorium:** approx. 800 persons, depending on the room geometry  
**Speakers / Side:** 1 x T9 / 1 x B5, 1 x B10 (mono)  
**Rec. Ampl. / Side:** T9: 1 power amplifier with 2 x 700-900 W RMS (1000 W peak) @ 4Ω  
 B5: 1 power amplifier with 2 x 700-800 W RMS / (850 W peak) @ 8Ω  
 B10: 1 power amplifier with min. 2 x 700-1000 W RMS (1000 W peak) @ 8 Ω  
**Controller / Side:** 1 x C5/9 or similar  
 1 x C 10 or similar

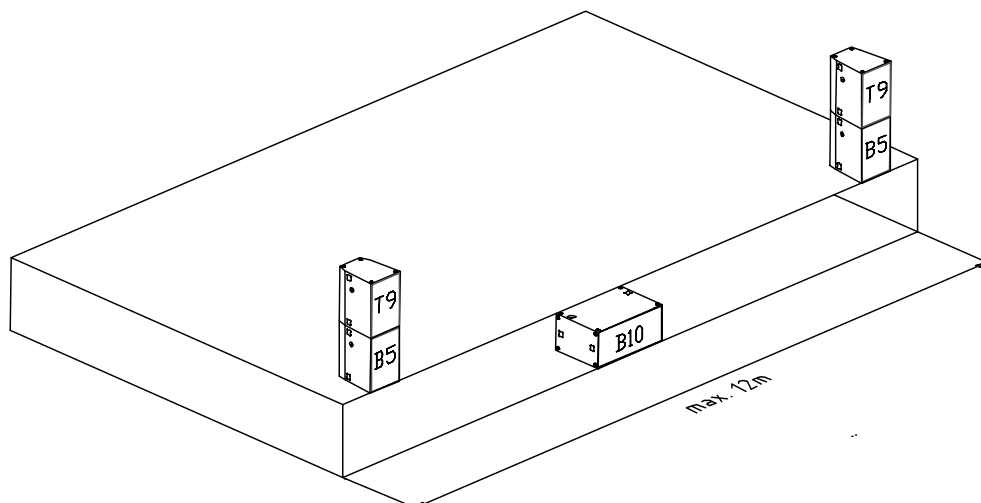

- 3. Application:** Rock / Pop / Disco  
**Auditorium:** approx. 800 persons, depending on room geometry  
**Speakers / Side:** 1xT9 / 2 x B5  
**Rec. Ampl. / Side:** T9: 1 power amplifier with 2x700-900 W RMS (1000 W peak) @ 4Ω  
 B5: 1 power amplifier with 2 x 1200-1400 W RMS (1700 W peak) @ 4Ω  
**Controller / Side:** 1 x C5/9 or similar

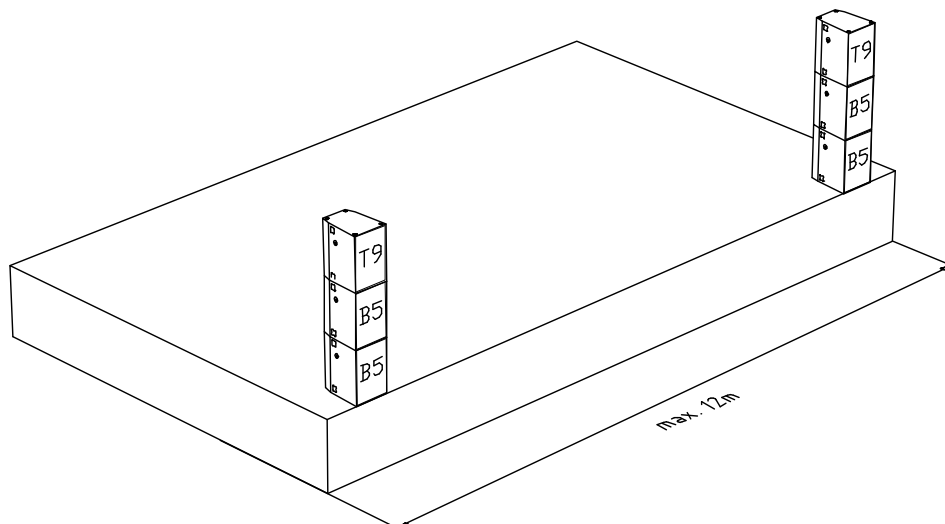

- 4. Application:** Rock / Pop / Disco / Techno, same as 3.0, but 1 x ACCESS B10 instead of 2 x ACCESS B5  
**Auditorium:** approx. 800 persons, depending on room geometry  
**Speakers / Side:** 1 x T9 / 1 x B10  
**Rec. Ampl. / Side:** T9: 1 power amplifier with 2 x 700-900 W RMS (1000 W peak) @ 4Ω  
 B10: 1 power amplifier with min.2 x 700-1000 W RMS (1000 W peak) @ 8Ω  
**Controller / Side:** 1 x C5/9 or similar  
 1 x C10 or similar

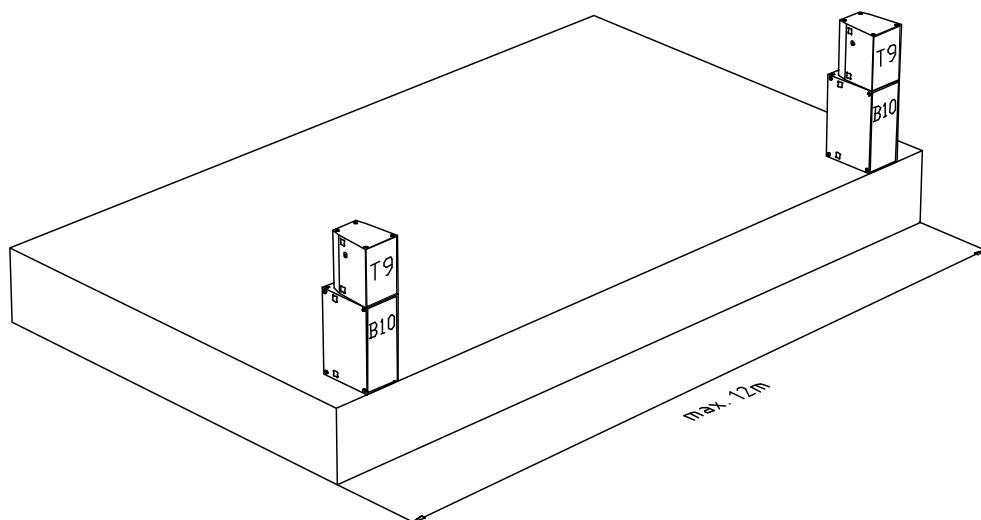

- 5. Application:** Acoustic-Jazz / Folk / Classics / speech  
**Auditorium:** approx. 1200 persons, depending on room geometry  
**Speakers / Side:** 1 x T9 inside / 1 x T5 outside / 2 x B5  
**Rec. Ampl. / Side:** T5 & T9: 1 power amplifier with 2 x 1100-1500 W RMS (2000 W peak) @ 2Ω  
 B5: 1 power amplifier with 2 x 1200-1400 W RMS (1700 W peak) @ 4Ω  
**Controller / Side:** 1 x C5/9 or similar

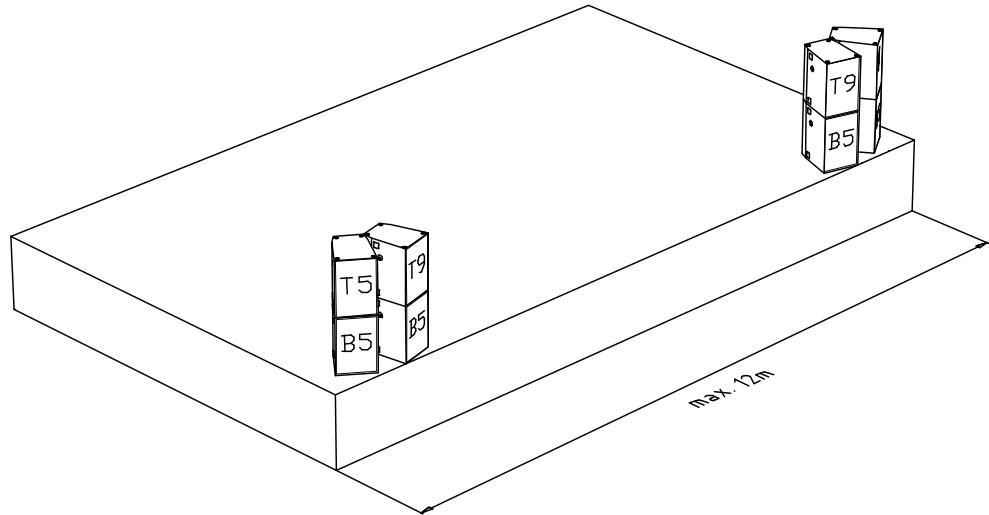

- 6. Application:** Rock / Pop / Disco / Techno  
 Option for wide rooms.  
 Stage width > 12m: sound distribution from stage edge!  
**Auditorium:** approx. 1800 persons, depending on room geometry  
**Speakers / Side:** 1 x T5 / 1 x T9 / 2 x B5 / 1 x B10  
**Rec. Ampl. / Side:** T5 & T9: 1 power amplifier with 2 x 1100-1500 W RMS (2000 W peak) @ 2Ω  
 B5: 1 power amplifier with 2 x 1200-1400 W RMS (1700 W peak) @ 4Ω  
 B10: 1 power amplifier with min. 2 x 700-1000 W RMS (1000 W peak) @ 8Ω  
**Controller / Side:** 1 x C5/9 or similar  
 1 x C10 or similar

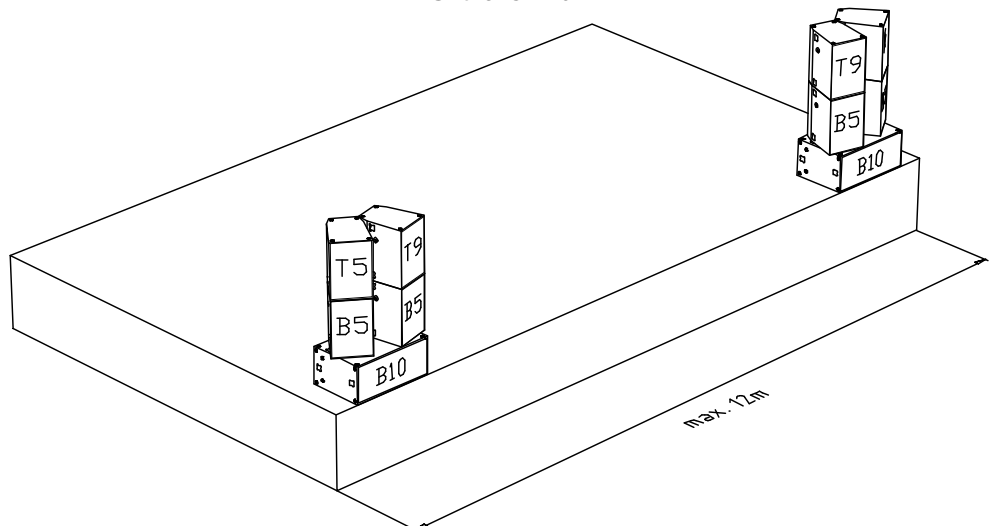

- 7. Application:** Classics / Jazz/ Rock / Pop / Disco  
 Option for wide rooms and stage width > 15m  
 Centre Cluster as direction reference as separate channel for soloists, talkers etc.
- Auditorium:** approx. 2500 persons, depending on room geometry
- Speakers / Channel:** left: 1 x T5 / 1 x T9 / 2 x B5 / 1 x B10  
 right: same as left  
 Centre: outside 2 x T9; inside 1 x T5 / 1 x B5
- Rec. Ampl. / Channel:** left: T5 & T9: 1 power amplifier with 2 x 1100-1500 W RMS (2000 W peak) @2Ω  
 B5: 1 power amplifier with 2 x 1200-1400 W RMS (1700 W peak) @ 4Ω  
 B10: 1 power amplifier with min. 2 x 700-1000 W RMS (1000 W peak) @ 8Ω  
 right: same as left  
 Centre: T9: 1 power amplifier with 2 x 1100-1500 W RMS (2000 W peak) @ 2Ω  
 T5: 1 power amplifier with 2 x 700-900 W RMS (1000 W peak) @ 4Ω  
 B5: 1 power amplifier with 2 x 700-800 W RMS / (850 W peak) @ 8Ω
- Controller / Channel:** Links: 1 x C5/9 or similar  
 1 x C10 or similar  
 right: same as left  
 Centre: 1 x C5/9 or similar for T9;  
 1 x C5/9 or similar for T5 / B5, (e.g. with High Boost for large distances)

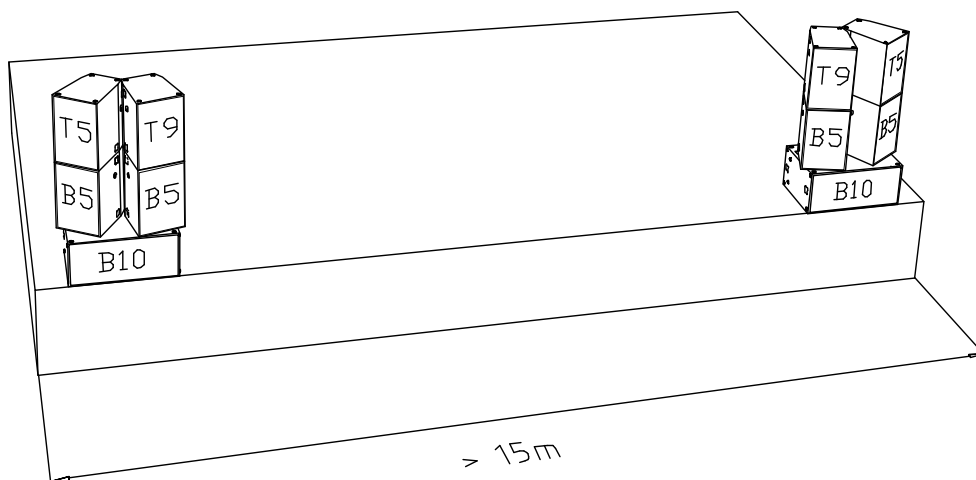
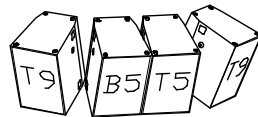

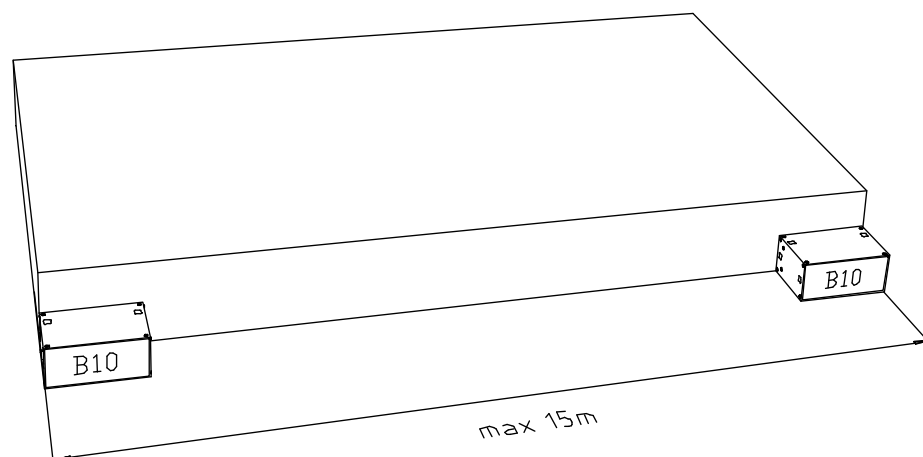
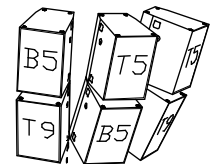
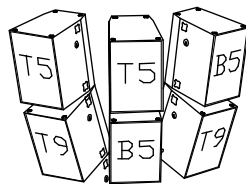

<b>8. Application:</b>	Classics / Jazz/ Rock / Pop / Disco Option for wide rooms with terraces, e.g. medium town halls. Stage width > 12m: sound distribution from stage edge!
<b>Auditorium:</b>	approx. 4000 persons, depending on room geometry
<b>Speakers / Side:</b>	2 x T5 / 2 x T9 / 2 x B5 / 1 x B10
<b>Rec. Ampl. / Side:</b>	T5: 1 power amplifier 2 x 1100-1500 W RMS (2000 W peak) @ 2Ω T9: 1 power amplifier 2 x 1100-1500 W RMS (2000 W peak) @ 2Ω B5: 1 power amplifier 2 x 1200-1400 W RMS (1700 W peak) @ 4Ω B10: 1 power amplifier min. 2 x 700-1000 W RMS (1000 W peak) @ 8Ω
<b>Controller / Side:</b>	T9 / B5: 1 x C5/9 or similar T5: 1 x C5/9 or similar B10 1 x C10 or similar (with High Boost for large distances)

**Comment:**

The configuration examples could be continued in this fashion; there are no limits for the dimensions. It is, however, recommendable to build a delay line into configurations as of a certain distance because of possible winds or echoes in large rooms.

To plan an acoustic irradiation beforehand, there are various programs such as "Ease", "Ulysses" or "CADP 2". The Kling & Freitag speaker system data for download is available from our website "[www.kling-freitag.de](http://www.kling-freitag.de)".

**18. Accessories for the ACCESS System**

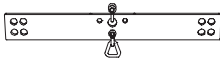

**Single Bar**

e.g for ACCESS T5, T9, B5, CA 1201, CA 1215, CA 1515, SW 112 (only with option 'Suspension'), SW 115D - XO, SW 118E, a.o. including Delta-bracket and 2 x 1/2" shackle  
colour: black

[2N]

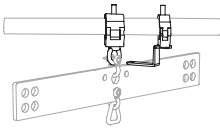

**Single Bar 'Align-Set' (supplement for [2N])**

1 x Half-Coupler wide with eyenut,  
1 x Half-Coupler narrow with M12 screw,  
1 x rotation-bracket, 1 x safety  
colour: black

[2O]

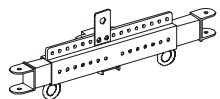

**ATM - ACCESS Main Bar**

Available at ATM ATM ([www.atm-fly-ware.com](http://www.atm-fly-ware.com)),  
part no. AT MEGS-575-T ATM MEGS series truss module; 575 mm  
colour: black

[2P]

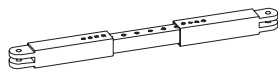

**ATM - ACCESS Splay**

colour: black

[2Q]

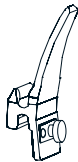

**ACCESS Curving Hook**

To optimise the rigging-curve of Access T5 / T9 und B5. Stabilises and aligns spækers that are Bown below one another. During tying up the strap, the spækers will slide in the right position. Especially recommended in combination with multi-functional ratched strap [3K]  
colour: black

[3J]



**Stud Plate K&F ACCESS**

(equal to MAN STUD Plate (HWSD)  
colour: black

[2R]



**Adjustable chain**

sinistral / dexter, shortenable, loadable max. 1t, with quality-signet  
colour: black

[2T]

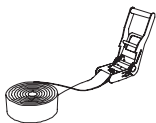

**Multi-functional ratchet strap**

for controlled releasing (sprocket for sprocket), 8 m, loadable max. 2t, recommended for using with ACCESS Curving Hook [3J]  
colour: black

[3K]

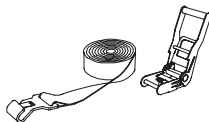

**Multi-functional ratchet strap two pieces**

for controlled releasing (sprocket for sprocket), 8 m, loadable max. 2t, recommended for using with ACCESS Curving Hook [3J]  
colour: black

[3K]

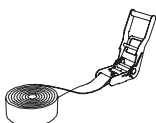

**Ratchet strap**

8 m, loadable max. 5t  
colour: black

[2U]

[2V] **EP-5 loudspeaker cable 2,5**  
flexible PVC sheathed cable, 4 x 2,5 mm<sup>2</sup>, EP-5 male / female  
colour: black  
2m, 5m, 10m, 20m

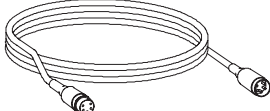

[2W] **EP-5 loudspeaker cable 4,0**  
flexible PVC sheathed cable, 4 x 4 mm<sup>2</sup>, EP-5 male / female  
colour: black  
2m, 5m, 10m, 20m



[3F] **Transport cover ACCESS T5 / T9 / B5**  
colour: black



[3G] **Transport cover ACCESS B10**  
colour: black



Applications:

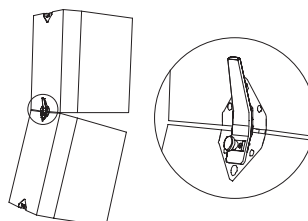
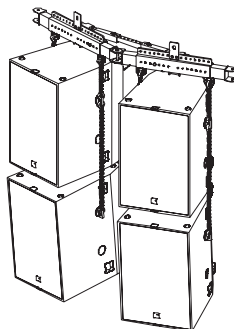
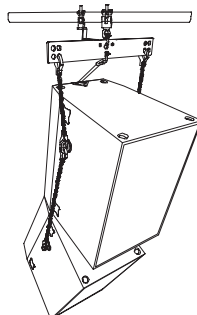

## 19. Regulations for Disposal

### 19.1 Germany:

**It is not allowed to dispose of used electrical equipment as domestic waste.**

But please do not dispose of them at official collecting points for recycling either!

All Kling & Freitag products are plain business-to-business (B2B) products. Disposal of Kling & Freitag products labelled with a waste bin sign have thus to be disposed of by Kling & Freitag alone. Please call Kling & Freitag at the number stated below if you have a Kling & Freitag product to be disposed. We will offer you a straightforward and professional disposal not affecting costs.

If there is no dustbin sign on one of your Kling & Freitag products, because they have been sold before March 2006 then by law the owner is in charge of the disposal. For these we will be happy to assist and offer you proper ways of disposal.

**Telephone number to call about the disposal of used Kling & Freitag products:  
+49 (511)-96 99 7-0**

Explanation:

With the ElektroG (law relating to electrical and electronic equipment and appliances) we have complied with the EU-directive on waste electrical and electronic equipment (WEEE, 2002/96/EC)

The Kling & Freitag AG has thus labelled all products mentioned in the WEEE from 03/24/2006 onwards with a sign with a crossed out waste bin and a white bar below. This sign indicates that the disposal into the domestic waste is prohibited and that the product has been put into circulation at the 03/24/2006 earliest.

The Kling & Freitag GmbH has been legally registered as a manufacturer with the registration office EAR. Our WEEE Registration-Nr. is: DE64110372

For the German Registration office EAR we have accredited that our products are sole B2B products.



### 19.2 EU, Norway, Island, and Liechtenstein (not Germany):

**It is not allowed to dispose of used electrical equipment as domestic waste.**

The Kling & Freitag AG has thus labelled all products coming from EU-Member countries as well as Norway, Island and Liechtenstein (except Germany) mentioned in the WEEE from 08/13/2005 onwards with a sign with a crossed out waste bin and a white bar below. This sign indicates that the disposal into the domestic waste is prohibited and that the product has been put into circulation at the 08/13/2005 earliest.

Unfortunately the European directive WEEE has been complied with implementing different national provisions of law throughout all member countries, which makes it impossible for us to offer consistent solutions for the disposal throughout Europe.

Responsible for complying with these provisions of law is the local distributor (importer) of each country.

For proper disposition of used products in accordance with these local provisions in the mentioned countries of the European Union (except Germany) please ask your local dealer or the local authorities.



### 19.3 Other countries

For proper disposition of used products in accordance with local provisions in other countries please ask your local dealer or the local authorities.