



## User's Manual

Version 4.3  
Stand: 28.08.2017



**Important Information,  
Please Read Before Use!**

KLING & FREITAG GmbH  
Junkersstrasse 14  
D-30179 Hannover  
PHONE 0 (049) 511- 969 97-0  
FAX 0 (049) 511- 67 37 94  
[www.kling-freitag.de](http://www.kling-freitag.de)



# Contents

## Inhaltsverzeichnis

<b>1.</b>	<b>Introduction</b>	<b>3</b>
<b>2.</b>	<b>Symbols in User's Manual</b>	<b>4</b>
<b>3.</b>	<b>Information about this User's Manual</b>	<b>4</b>
<b>4.</b>	<b>General Instructions for Using Speakers</b>	<b>5</b>
<b>5.</b>	<b>Product Descriptions and Versions</b>	<b>7</b>
5.1	CA 1201	7
5.2	CA 1215-6	8
5.3	CA 1215-9	9
5.4	CA 1515-6	10
5.5	CA 1515-9	11
<b>6.</b>	<b>Important Notes for the Options 'Outdoor' and 'Installation'</b>	<b>12</b>
6.1	'Installation'	12
6.2	'Outdoor Mobile'	12
6.3	'Outdoor Installation'	12
<b>7.</b>	<b>Notes for Versions with '100V' Option</b>	<b>13</b>
7.1	Reasons for choosing Speakers with 100 V Transformers	13
7.2	Connecting Diagram of the 100V Speaker Inputs	13
<b>8.</b>	<b>Instructions for Suspending the Speakers</b>	<b>14</b>
8.1	Rigging without K&F Adjustable Speaker Mount or Ceiling Bracket	14
8.2	Using the 'allsafe JUNGFALK' Flying Points	15
<b>9.</b>	<b>Coverage Patterns of the CA Speakers</b>	<b>16</b>
9.1	Changing the Coverage Pattern	16
<b>10.</b>	<b>Mounting Instructions for Speakers</b>	<b>17</b>
10.1	Proper Arrangement of the Loudspeakers	17
10.2	Arrayed Speaker Systems (Cluster)	18
10.2.1	Horn not rotated	18
10.2.2	With rotated Horn	19
<b>11.</b>	<b>Wiring</b>	<b>20</b>
11.1	Connecting the Speakon Connector to the Terminal	20
11.2	Avoiding Ground Loops	21
11.2.1	What is a Ground Loop?	21
11.2.2	Avoiding Ground Loops	21
<b>12.</b>	<b>Configurations and Connecting Diagrams</b>	<b>22</b>
12.1	Operating the Systems without K&F System Controller	22
12.1.1	CA Systems in Full-Range Mode	22
12.1.2	Full Range Mode & Subwoofer with Crossover (XO)	23
12.2	Operations with K&F System Controller	24
<b>13.</b>	<b>Operating the Speakers</b>	<b>24</b>
<b>14.</b>	<b>Crossovers</b>	<b>25</b>

14.1	Wiring Diagram CA 1201	25
14.1.1	Version A	25
14.1.2	Version B	26
14.2	Wiring Diagram CA 1215-6 and CA 1215 -9	27
14.2.1	Version A	27
14.2.2	Version B	28
14.3	Wiring Diagram CA 1515-6 and CA 1515-9	29
14.3.1	Version A	29
14.3.2	Version B	30
<b>15.</b>	<b>Touching Up Damage to Paint / Changing the Front Foam</b>	<b>30</b>
<b>16.</b>	<b>Technical Specifications</b>	<b>31</b>
16.1	CA 1201	31
16.2	CA 1215-6	32
16.3	CA 1215-9	33
16.4	CA 1515-6	34
16.5	CA 1515-9	35
<b>17.</b>	<b>Measuring Charts</b>	<b>36</b>
17.1	CA 1201	36
17.2	CA 1215-6	38
17.3	CA 1215-9	40
17.4	CA 1515-6	42
17.5	CA 1515-9	44
<b>18.</b>	<b>Dimensions</b>	<b>46</b>
18.1	CA 1201, CA 1215-6 and CA 1215-9	46
18.2	CA 1201-M, CA 1215-6-M and CA 1215-9-M	47
18.3	CA 1201, CA 1215-6 and CA 1215-9 with Option 'Installation'	48
18.4	CA 1515-6 and CA 1515-9	49
18.5	CA 1515-6 and CA 1515-9 with Option 'Installation'	50
18.6	Accessories for the CA Systems	51
<b>19.</b>	<b>Disposal</b>	<b>53</b>
19.1	Germany	53
19.2	EU, Norway, Iceland, and Liechtenstein	53
19.3	All other Countries	53

## 1. Introduction

Thank you for your decision to buy a Kling & Freitag product. To guarantee a trouble-free operating of the equipment and to enable the KLING & FREITAG CA speaker system to achieve its full potential, please read the operating instructions carefully before use.

With the purchase of a CA system, you have acquired a speaker system with the highest possible quality and performance capabilities.

As the owner of this system, you now have a versatile and highly professional tool which, when operated properly, is a true pleasure to use.

## 2. Symbols in User's Manual



### Warning

This symbol indicates the possibility of life-threatening danger and a health risk for persons. Not following these instructions may result in serious health problems including potentially fatal injuries.



### Caution

This symbol indicates a possibly dangerous situation. Not following these instructions may cause minor injuries or cause property damage.



### Important

This symbol gives instructions for the proper use of the described products. Not following these instructions may cause malfunctions or property damage.

## 3. Information about this User's Manual

User's Manual CA 1201, CA 1215-6 /-9, CA 1515-6 /-9 Version 4.2, 28.08.2017

© by André Figula, Kling & Freitag GmbH, 1998 - 2017; all rights reserved.

All specifications in this manual are based on information available at the time of publishing for the features and safety guidelines of the described products.

Technical specifications, measurements, weights and properties are not guaranteed.

The manufacturer reserves the right to make product alterations within legal provisions as well as changes to improve product quality.

**All persons who use the speaker system must have this guide and all further information for safe operations available to them during assembly, disassembly, and use.**

We appreciate any input with suggestions and improvements for this manual.

Please send this to us at the following address:

info@kling-freitag.de

or to:

KLING & FREITAG GMBH Junkersstr.14 D-30179 Hannover

Phone +49 (0) 511 - 96 99 70 Fax +49 (0) 511 - 67 37 94

## 4. General Instructions for Using Speakers



### Warning

#### Mounting the speakers

To prevent injury, the speakers must be securely placed on the floor or secured to the wall according to the instructions on page 17 (Mounting Instructions for Speakers). Please note that speakers can move as a result of vibrations. To prevent them from falling from their mounted position, they must be secured properly. If the weight of the speaker exceeds 20 kg then it is necessary for two people to carry it.

Speakers may only be suspended or mounted to walls or ceilings by qualified personnel. The speakers must be hung by using at least two of the designated flying points. The same applies when lifting and aligning the speakers.

Never use signal cables or power cords for suspending, aligning or securing the systems. When laying the connecting cables, make sure that nobody can trip.

Never hang more than two speakers under one another without using the designated Kling & Freitag rigging equipment.

Ensure that all installation connections comply with the applicable safety guidelines and that the size and strength are sufficient. Further instructions are in our user's manual for assembly equipment and in the general safety instructions for speakers and assembly equipment.

For mobile and fixed installations, use only rigging equipment from KLING & FREITAG. Make sure to observe the included safety and mounting instructions for loudspeakers and accessories.

Speakers and rigging equipment must be visually examined at regular intervals. If there are signs of wear, they must be replaced immediately. Furthermore, screwed connections of supporting parts must be checked routinely.

#### Protecting the speakers / avoiding fire hazard



### Warning

In general, audio signals should not be overdriven. This may be caused by mixing consoles, equalizers, effect equipment, etc. and should be indicated on this equipment. When a power amplifier is overloaded at the output (clipping), then the amplifier should activate a clipping warning signal. Power amplifiers can also be overloaded at the input circuit without the amplifier signalling the clipping, i.e. when there is not sufficient headroom in the input circuit. We, therefore, recommend turning up the power amplifiers all the way and adjusting the level before the power amplifier in order to avoid overloading the input circuit. In any case, the signal must be reduced as soon as it sounds unnaturally distorted.

To protect the speakers from being destroyed and to avoid fire hazard, they should only be operated with professional power amplifiers with the following specifications:

Integrated or preceding subsonic filter (approx. 30 Hz, min. 12 dB / octave)

integrated clipping limiter

for speaker models CA 1201 or CA 1215:

maximum rated power 500W@8Ohm(equivalent 1000W@4Ohm)

for speaker model CA 1515:

maximum rated power 700W@8Ohm (equivalent 1400W@4Ohm)

If you wish to use a speaker with a power amplifier which does not fulfil these specifications, then the speaker should be controlled using a Kling & Freitag system controller with limiter function. This is the only way overloading and the risk of fire can be avoided. The results of such a power amplifier defect cannot be avoided by the controller.

Important

**Important**

If power amplifiers have power ratings lower than mentioned above, then it is imperative that a clipping limiter is used to protect the speaker even if it is used with a Kling & Freitag system controller.

For damage caused by overloading or use with power amplifiers other than those recommended above, Kling & Freitag GmbH does not assume warranty and excludes liability for possible consequential damage.

**Important**

### **The following signals may damage the speakers**

Permanent high-pitched signals with high frequency, and continuous noise from feedback.

Permanently distorted signals with high power.

Noises, which occur when the amplifier is on while equipment is being connected, disconnected or switched on.

### **Do not install speakers in any of the following places:**

Where the speakers are permanently exposed to direct sunlight

Where the speakers are exposed to high moisture

Where the speakers are exposed to strong vibrations and dust.

### **Damage caused by the speakers' magnetic fields**

Speakers are permanently surrounded by a magnetic field even when they are not operating. Therefore, during transport and placement of the speakers, it is important to ensure that there is always approx. 1 m between the speakers and magnetic data media and computer/video monitors.

**Caution**

### **Preventing hearing damage**

To prevent the risk of hearing damage, avoid being too close to operating speakers, even if the volume level seems to be low enough. In general, volume levels over 90 dB can cause hearing damage.

## 5. Product Descriptions and Versions

### 5.1 CA 1201

#### Short description:

2-way full-range speaker system with 12" low-mid chassis and 1" high frequency driver on a rotatable 90° x 60° CD horn. Homogeneous coverage and constant directivity starting at 1.2 kHz. Integrated crossover with self-resetting protection circuit for low-mid and high frequency path.

#### Enclosure:

Trapezoidal enclosure with additional cluster angles, 15 mm birch plywood, highly resistant structured grey or black finish, internal mounting flange, 5 'allsafe JUNGFALK' flying points, 2 butterfly handles, highly permeable, ball proof steel grille with exchangeable black acoustic foam.

#### Optional versions:

- CA 1201-M:  
Enclosure with additional monitor angle
- CA 1201-100V:  
100V version with 300 VA toroidal transformer
- CA 1201 – 'Installation'  
Version for fixed installations
- CA 1201 – 'Outdoor Installation' / 'Outdoor Mobile'  
Versions for outdoor use under roofs
- CA 1201-SP:  
Version with integrated power amplifier technology (not for CA 1201-M)  
'SP' speakers are shipped with a separate user's manual!
- Special finish in RAL colours

## 5.2 CA 1215-6

### Short description:

2-way high-performance speaker system with 12" low-mid chassis and 1.5" high frequency horn driver on a rotatable 65° x 50° CD horn. Homogeneous coverage and constant directivity starting at 1.2 kHz. Integrated crossover with self-resetting protection circuit for high frequency path, delay time and phase optimisation.

### Enclosure:

Trapezoidal enclosure with additional cluster angles, 15 mm birch plywood, highly resistable structured grey or black finish, internal mounting flange, 5 'allsafe JUNGFALK' flying points, 2 butterfly handles, highly permeable, ball proof steel grille with exchangeable black acoustic foam.

### Optional versions:

- CA 1215-6-M:  
Enclosure with additional monitor angle
- CA 1215-6 100V:  
100V version with 300 VA toroidal transformer
- CA 1215-6 - 'Installation'  
Version for fixed installations
- CA 1215-6 - 'Outdoor Installation' / 'Outdoor Mobile'  
Versions for outdoor use under roofs
- CA 1215-6-SP:  
Version with integrated power amplifier technology (not for CA 1215-6-M)  
'SP' speakers are shipped with a separate user's manual!
- Special finish in RAL colours

## 5.3 CA 1215-9

### Short description:

2-way high-performance speaker system with 12" low-mid chassis and 1.5" high frequency driver on a rotatable 90° x 50° CD horn. Homogeneous coverage and constant directivity starting at 1.0 kHz. Integrated crossover with self-resetting protection circuit for high frequency path, delay time and phase optimisation.

### Enclosure:

Trapezoidal enclosure with additional cluster angles, 15 mm birch plywood, highly resistant structured grey or black finish, internal mounting flange, 5 'allsafe JUNGFALK' flying points, 2 butterfly handles, highly permeable, ball proof steel grille with exchangeable black acoustic foam.

### Optional versions:

- CA 1215-9-M:  
Enclosure with additional monitor angle
- CA 1215-9-100V:  
100V version with 300 VA toroidal transformer
- CA 1215-9 - 'Installation'  
Version for fixed installations
- CA 1215-9 - 'Outdoor Installation' / 'Outdoor Mobile'  
Version for outdoor use under roofs
- CA 1215-9-SP:  
Version with integrated power amplifier technology (not for CA 1215-9-M)  
'SP' speakers are shipped with a separate user's manual!
- Special finish in RAL colours

## 5.4 CA 1515-6

### Short description:

2-way high-performance speaker system with 15" low-mid chassis and 1.5" high frequency driver on a rotatable 65° x 50° CD horn. Homogeneous coverage and constant directivity starting at 1.2 kHz. Integrated crossover with self-resetting protection circuit for chassis and crossover, delay time and phase optimisation.

### Enclosure:

Trapezoidal enclosure with additional monitor and cluster angles, 15 mm birch plywood, highly resistant structured grey or black finish, internal mounting flange, 5 'allsafe JUNGFALK' flying points, 2 butterfly handles, highly permeable, ball proof steel grille with exchangeable black acoustic foam, non-abrasive plastic feet.

### Optional versions:

- CA 1515-6-100V:  
100V version with 300 VA toroidal transformer
- CA 1515-6 - 'Installation'  
Version for fixed installations
- CA 1515-6 - 'Outdoor Installation' / 'Outdoor Mobile'  
Version for outdoor use under roofs
- CA 1515-6-SP:  
Version with integrated power amplifier technology (not for 1515-9-M)  
'SP' speakers are shipped with a separate user's manual!
- Special finish in RAL colours

## 5.5 CA 1515-9

### Short description:

2-way high-performance speaker system with 15" low-mid chassis and 1.5" high frequency driver on a rotatable 90° x 50° CD horn. Homogeneous coverage and constant directivity starting at 1.0 kHz. Integrated crossover with self-resetting protection circuit for chassis and crossover, delay time and phase optimisation.

### Enclosure:

Trapezoidal enclosure with additional monitor and cluster angles, 15 mm birch plywood, highly resistant structured grey or black finish, internal mounting flange, 5 'allsafe JUNGFALK' flying points, 2 butterfly handles, highly permeable, ball proof steel grille with exchangeable black acoustic foam, non-abrasive plastic feet.

### Optional versions:

- CA 1515-9-100V:  
100V version with 300 VA toroidal transformer
- CA 1515-6 - 'Installation'  
Version for fixed installations
- CA 1515-9 - 'Outdoor Installation' / 'Outdoor Mobile'  
Version for outdoor use under roofs
- CA 1515-9-SP:  
Version with integrated power amplifier technology (not for 1515-9-M)  
'SP' speakers are shipped with a separate user's manual!
- Special finish in RAL colours

## 6. Important Notes for the Options 'Outdoor' and 'Installation'



Speakers with the option 'Outdoor Mobile' and 'Outdoor Installation' have been optimised for outdoor use. They withstand temperature fluctuations in moderate climate zones and do not accumulate condensation water.

In order to guarantee the longevity and safety of the speakers, the speakers with the option 'Outdoor' must still be protected from direct effects of the weather.

They should be installed, for example, under a roof so that they also have sufficient protection from driving rain from the side and direct sunlight.

### 6.1 'Installation'

Version for fixed indoor installations.

Features like standard version but:

- without feet and handles
- seven stainless steel flying points with internal M10 threads,
- stainless steel connecting terminal with single PG cable fitting, Ø 13 mm

Connector:

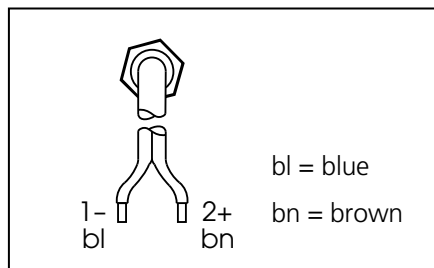

### 6.2 'Outdoor Mobile'

Version for mobile outdoor use under roofs.

Features like standard version but with the following extras:

- multi-layered, temperature and UV-resistant high-tech PU marine primer,
- final coating with highly resistant structured 2K paint in RAL colours,
- waterproofed diaphragms and electronic components protected against corrosion with protective coating.

### 6.3 'Outdoor Installation'

Version for fixed outdoor installations under roofs.

Features like 'Outdoor Mobile', but:

- without feet and handles.
- seven stainless steel flying points with internal M10 threads
- stainless steel grille
- foam covering behind grille
- visible screws made of stainless steel.
- Stainless steel connecting terminal with single PG cable fitting, Ø 13 mm (connecting scheme see version 'Installation')

## 7. Notes for Versions with '100V' Option

Kling & Freitag speakers with '100V' option are fitted with high-quality toroidal trans-formers. This serves to minimize loss of sound. Highly professional sound reinforcement results can be achieved using 100 V Kling & Freitag speakers.



**Important**

### 7.1 Reasons for choosing Speakers with 100 V Transformers

- Reduction in conduction loss.
- Easy installation of a loudspeaker network due to simple parallel wiring.  
The sum of the output power of the individual speakers (stated as VA = W) must not exceed the output power of the 100 V amplifier.
- Speakers are galvanically isolated.
- Speakers can be integrated into existing 100 V systems.

### 7.2 Connecting Diagram of the 100V Speaker Inputs

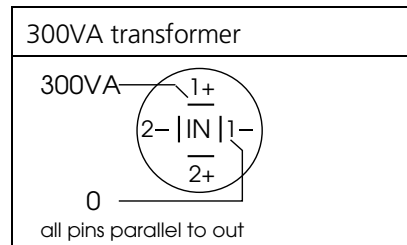

## 8. Instructions for Suspending the Speakers

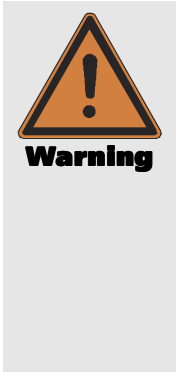

The speakers may only be suspended by trained specialised personnel.

**Pay attention to the required safety factors. Please follow the accompanying safety and assembly instructions carefully as well as the corresponding national safety regulations.**

All sound systems used are to be secured against toppling or falling in the manner required by the carriers of the statutory accident insurances for studio or stage areas. Appropriate directions can be found in BGV C1, BGI 810-3 or corresponding local national safety guidelines.

Ensure that all connections are secured against coming loose and that only authorized, statically tested and correctly sized supports, mounting equipment, wire ropes and chains are used.



### 8.1 Rigging without K&F Adjustable Speaker Mount or Ceiling Bracket

**A one-strand rigging without additional safety is not permitted!**

**A safety on one rear connection point with no zero drop height is permitted!**

The rear connection points are only suitable for additional tying off the speaker.

**Note that you can fly a maximum of two of these loudspeakers at the same strand rigging!**

<b>Variante 1, vertical:</b>	
<p>At a vertical rigging without a K&amp;F U-Mount you have to fix the loudspeaker at the upper or bottom connection points. The rear connection points are only suitable for additional tying off the speaker.</p> <p>The two mounting devices (chains, wire ropes) have to be independent and parallel and must be implemented with zero drop height.</p>	
<b>Variante 2, horizontal:</b>	
<p>At an horizontally rigging without a K&amp;F ceiling bracket you have to fix the loudspeaker at one flying point each side. The rear connection points are only suitable for additional tying off the speaker.</p> <p>The two mounting devices (chains, wire ropes) have to be independent and parallel and must be implemented with zero drop height.</p>	

There are several flying options, if you use a K&F U-Mount or K&F ceiling bracket. These mounts are designed specifically for each speaker systems. For further information, please contact our local dealer.

Ensure that all installation connections comply with the applicable safety guidelines and that the size and strength are sufficient. Further instructions are in our user's manual for assembly equipment and in the general safety instructions for speakers and accessories.

## 8.2 Using the 'allsafe JUNGFALK' Flying Points



Take the single stud fitting in one hand...



... and push the locking device up against the spring tension.



Put the flat head of the holding bolt into the guiding of the flying point.



Release the locking device when the single stud fitting is located in the middle of the flying point. Make sure that the locking device clicks into place.



Check that the single stud fitting is securely fastened and cannot be pulled out.

## 9. Coverage Patterns of the CA Speakers

The mid-high systems can be operated in a vertical or horizontal (i.e. as a stage monitor) position. The coverage pattern of the speakers can be adapted to special needs by a 90° rotatable horn.

The table below shows the coverage angles of a standing speaker: To determine the coverage pattern of the high frequency horn, shine a flashlight through the front covering at the level of the horn. You will find a silver stripe that determines the position and coverage angles of the horn.

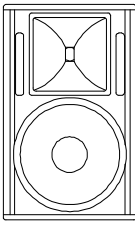
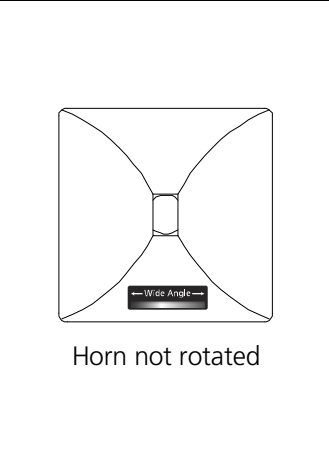
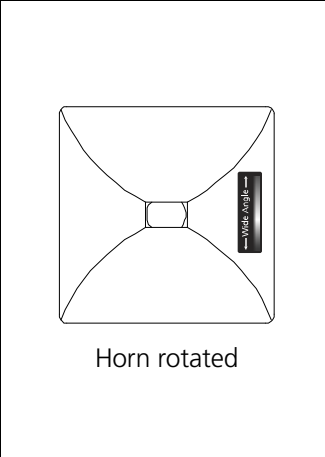
DEFINITION:		
 Standing speaker:	 Horn not rotated	 Horn rotated
Model	Horn not rotated	Horn rotated
CA 1201	90° h x 60° v	60° h x 90° v
CA 1215-6	65° h x 50° v	50° h x 65° v
CA 1215-9	90° h x 50° v	50° h x 90° v
CA 1515-6	65° h x 50° v	50° h x 65° v
CA 1215-9	90° h x 50° v	50° h x 90° v

### 9.1 Changing the Coverage Pattern

**To turn the horn, follow these steps:**

1. Remove the four grille mounting screws on the top and bottom of the speakers with a 3 mm Allen key and remove the grille from the speaker enclosure.
2. Remove the screws from the high frequency horn (also using a 3 mm Allen key). Loosen the high frequency horn by using both hands, palms to the outside, to grasp into the horn and lift the horn with even pressure from the palms of your hands towards the outside. Should the horn adhere to the foam rubber attached below, release it using a screwdriver or something similar to gently lever it up.
3. Rotate the horn 90° and screw the horn on tightly again (do not force it!).
4. Screw the grille on tightly.

If the coverage angle needs to be changed often, make sure that the horn is not always rotated in the same direction, as the connecting cables, when twisted, may cause the contacts of the driver to become loose.

## 10. Mounting Instructions for Speakers



Mount the speakers securely. To avoid injury or damage, always be sure to mount the speakers securely so that they do not fall. Speakers, which are stacked, must be secured with securing straps. When laying the connecting cables, make sure that nobody can trip.

The stability of stacked systems (also valid for the use of stands and distance rods!) is contingent upon the following stability requirement. These conditions must, therefore, be guaranteed by the user:

**Stacked systems may not fall over even if they are inclined by 10° in each direction. If this requirement is not fulfilled, then it is necessary to take steps to achieve compliance. Possible measures include strapping it to an appropriate base structure or fastening it using safety straps.**

### 10.1 Proper Arrangement of the Loudspeakers

Be aware of the fact that the logical targeted alignment of this high quality speaker system can lead to a significant qualitative increase in the acoustic result. It is not possible to make generalities about the alignment of specific systems because the room has a substantial influence on the signal and the audible result.

As a rule, the mid- and high-transducers of loudspeakers should be mounted above the audience's face value, so that the sound distribution cannot be shadowed.

In many cases it is advisable to mount a loudspeaker higher, so that the sound will be distributed throughout the room more evenly. Low standing systems result in a greater difference in volume between front and back seats than higher standing systems.

Please note that this is only a general guideline and the best possible result may vary from room to room.

To simulate the correct alignment of the speakers beforehand, there are various programs such as 'Ease' or 'Ulysses'. The Kling & Freitag speaker system data is available for download on our website [www.kling-freitag.de](http://www.kling-freitag.de).

The following graphics will assist in making a rough estimate as to the distance range of full-range systems. The graphics only take into consideration the sum of the direct sound and not the influence of the room. Because of this there can, in some cases, be noticeable deviation.

**Distance range of SPL (direct sound level):**

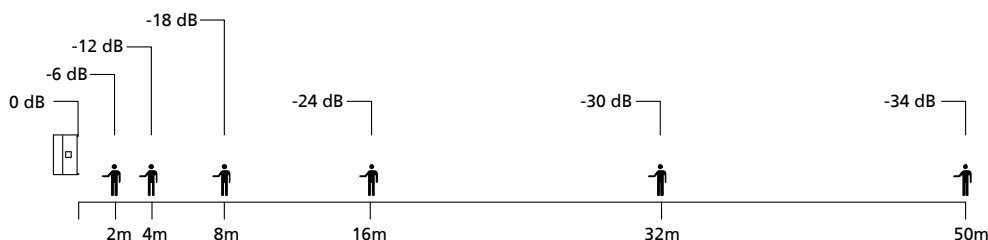

## 10.2 Arrayed Speaker Systems (Cluster)

If the loudspeakers are operated through the optional K&F System Controller, we recommend to turn on the 'Top Low Cut' filter for clustered operation. Thus the frequency response for this application can be optimised (see also user's manual of the K&F System Controller).

When operating the systems without a K&F System Controller in a clustered con-figuration, the signal level of frequencies below 300 Hz should be reduced by 3-4 dB.

### 10.2.1 Horn not rotated

<p>Horn not rotated</p>	<p>Standing speaker</p>	<p>between middle axes</p>	<p>A smaller angle 3 results in a smaller vertical coverage angle but increases the sound power level.</p>
	<p>between the sides of the speakers</p>		
Combination	Angle 1	Angle 2	Angle 3
CA 1201 with CA 1201	45°-55° not generally recommended*	55°-65° not generally recommended*	20°-35
CA 1215-6 with CA 1215-6	30°	40°	20°-30°
CA 1215-6 with CA 1215-9	35°	45°	
CA 1215-9 with CA 1215-9	40°-50° not generally recommended*	50°-60° not generally recommended*	
CA 1515-6 with CA 1515-6	30°	40°	
CA 1515-6 with CA 1515-9	35°	45°	
CA 1515-9 with CA 1515-9	40°-50° not generally recommended*	50°-60° not generally recommended*	
Application	Increasing the horizontal coverage angle, e.g. for wide audience planes	Increasing the horizontal coverage angle and sound power level for larger distances	Increasing the vertical coverage angle, e.g. for covering balconies or for increased sound power level for larger distances

\*If several 90° systems are clustered, unwanted interference effects may appear. As a result, we do not generally recommend clustered configurations of CA 1201, CA 1215-9 and CA 1515-9 systems. If wide angles are to be covered, we recommend the use of several 60° or 65° systems in one cluster.

**10.2.2 With rotated Horn**

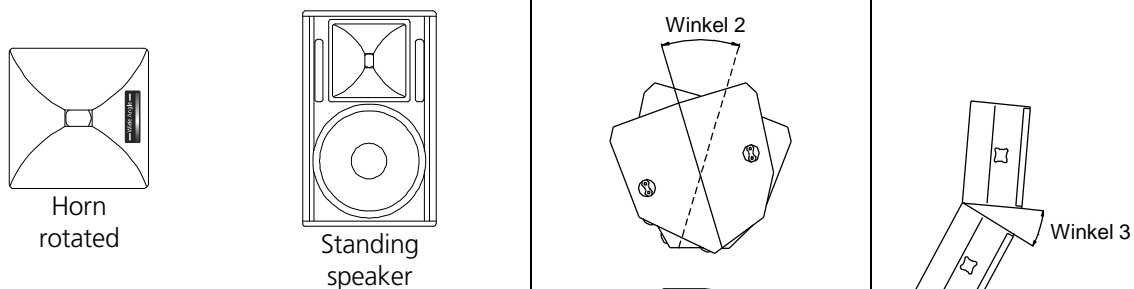

A smaller angle 3 results in a smaller vertical coverage angle but increases the sound power level.

Combination	Angle 1	Angle 2	Angle 3
CA 1201 with CA 1201	25°	35°	Not recommended
CA 1215-6 with CA 1215-6	20°	30°	30°-40°
CA 1215-6 with CA 1215-9			30°-45°
CA 1215-9 with CA 1215-9			Not recommended
CA 1515-6 with CA 1515-6			30°-40°
CA 1515-6 with CA 1515-9			30°-45°
CA 1515-9 with CA 1515-9			Not recommended
Application			Increasing the horizontal coverage angle, e.g. for wide audience planes

## 11. Wiring

The speaker is equipped with two parallel Speakon connectors.

Make sure that all units are switched off and all controls are turned down before connecting your CA systems.

- We recommend the use of high-quality speaker cables provided by KLING & FREITAG.
- For connections to the power amplifier inputs, please use 2-pin shielded microphone cable with high-quality connectors.
- Avoid ground loops (see chapter 11.2)
- Please pay attention to the respective pin diagrams in this manual!
- Make sure that the +/- polarity of the speakers at the amplifier is correct. When simultaneously using power amplifiers from different manufacturers, be sure to use the correct specific pin configuration. It may be necessary to modify the pin configuration on the power amplifiers or on the connectors leading to them.
- Upon completing the wiring, ensure that the connected speaker channels are working in phase. To do so, use i.e. a phase checker. A phase error can also be recognized when the connected channels are used simultaneously. During simultaneous use the bass frequencies become notably quieter or the mid-frequencies such as voices cannot be located.



### Important

- To avoid loss of power, the cables should have a minimum wire gauge of 2.5 mm<sup>2</sup> - more for longer cabled distances. A minimum wire gauge can be easily calculated with the following formula:

$$\text{Minimum Wire Gauge (mm}^2\text{)} = \frac{\text{Required Cable Length (m)}}{2 \times \text{Speaker Impedance (}\Omega\text{)}}$$

If several loudspeakers are connected, the signal can be linked through from one loudspeaker to the next. Please make sure that the total impedance of the loudspeakers  $R(\bullet)$  is not lower than the minimal impedance indicated on the power amplifier.

$$1/R_1 + 1/R_2 + 1/R_3 + \dots = 1/R_{\text{total}}$$

### 11.1 Connecting the Speakon Connector to the Terminal

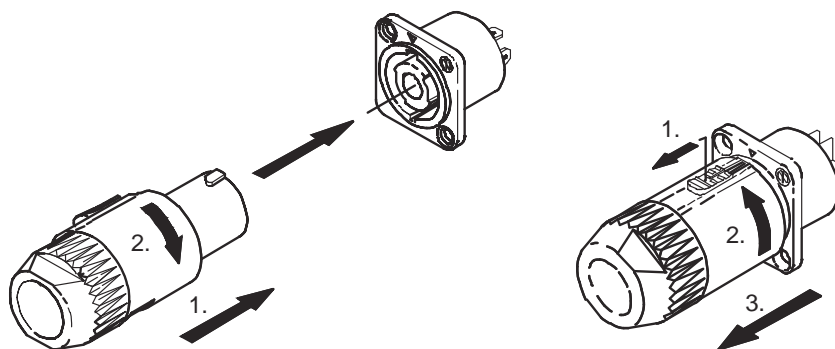

## 11.2 Avoiding Ground Loops

### 11.2.1 What is a Ground Loop?

Every component of a P.A. or Hi-Fi System has its own internal 0 V reference (ground). This point is often connected to the protective earth connector (PE / Ground). If two or more units are connected to one another with a line level audio cable, there may be a ground connection through the ground of the power supply cable (yellow-green) as well as through the shielding of the audio cable. The voltage difference between these two ground points causes audible interference to come from the speaker

### 11.2.2 Avoiding Ground Loops

If there is a loud humming or buzzing after the CA System has been connected, then check that a "ground loop" has not been built into the system. Some power amplifiers and system controllers are equipped with a "Ground Lift" switch. Set these switches to the "Lift" position one after the other. If the noise is still audible, check if,

1. the noise is caused by a ground loop before the power amplifiers / controllers (e.g. mixing console, effects or equalizers).
2. the system or parts of the system are connected to an "unclean" power supply - meaning one, which is also running large motors, or lighting systems. An "unclean" supply voltage, electrostatic and electromagnetic fields can cause a malfunction.

#### Please observe the following basic rules:



- Never!!! try to avoid a ground loop by disconnecting or taping the ground contact at the power connector! Extremely dangerous!
- If possible, only use high-quality audio appliances with balanced signal outputs and with power cables with PE connectors.
- Use high-quality cables with good shielding.
- The point of ground for all connected components should merge at one central point. The power connections should lead out in a radial manner from one point and not be linked from one unit to the next.
- When installing appliances that create strong electrostatic or electromagnetic fields (large transformers, switch-mode power supplies), maintain some distance from other audio appliances. In extreme cases, the only solution is to create a completely independent "audio ground"; in other cases, it is sufficient to connect a filter in front of the audio equipment.

## 12. Configurations and Connecting Diagrams

### 12.1 Operating the Systems without K&F System Controller



The full-range systems can be used alone or in conjunction with a K&F subwoofer with integrated crossover (e.g. SW 112-XO / SW 115D-XO SW 115E-XO or SW 118E-XO). In this mode of operation the crossover limits the subwoofer's frequency range.

- To protect the speakers from being destroyed and to avoid fire hazard, they should only be operated with professional power amplifiers with the following specifications:
  - integrated or preceding subsonic filter (approx. 30 Hz, min. 12 dB / octave)
  - integrated clipping limiter
  - for speaker model CA 1201 or CA 1215:  
maximum rated power 500W@8Ohm (equivalent 1000W@4 Ohm)
  - for speaker model CA 1515:  
maximum rated power 700W@8 Ohm (equivalent 1400W@4 Ohm)

If you wish to use a speaker with a power amplifier which does not fulfil these specifications, then the speaker should be controlled using a Kling & Freitag System Controller with limiter function. This is the only way overloading and the risk of fire can be avoided. The results of such a power amplifier defect cannot be avoided by the controller.

#### 12.1.1 CA Systems in Full-Range Mode

This mode of operation is ideal for speech applications and music applications without the need for a high bass content. Should more bass be needed, the bass level can be increased between 50 and 80 Hz at the mixing console.

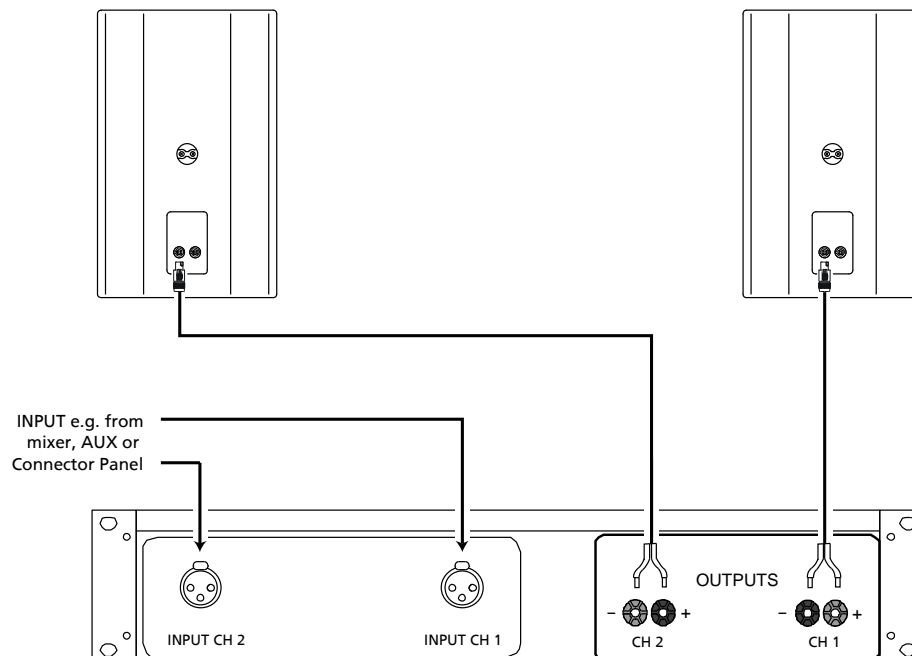

If you are operating a mid-high system in a cluster (speakers arranged in close proximity) or as a stage monitor, reduce the frequencies below 300 Hz by 3-4 dB! (The K&F System Controllers have a special 'Top Low Cut' filter function for this purpose.)

**12.1.2 Full Range Mode & Subwoofer with Crossover (XO)**

In this mode of operation you can easily realise applications, where a higher bass level is needed.

In this mode of operation be sure to use only amplifiers, which can handle speaker impedances down to 3 •.



**Recommended combinations of CA systems, as described here, with K&F subwoofers:**

- 2 CA systems + 2- 4 x SW 112-XO
- 2 x SW 115D-XO
- 2 x SW 115E-XO
- 1 - 2 x SW 118E-XO

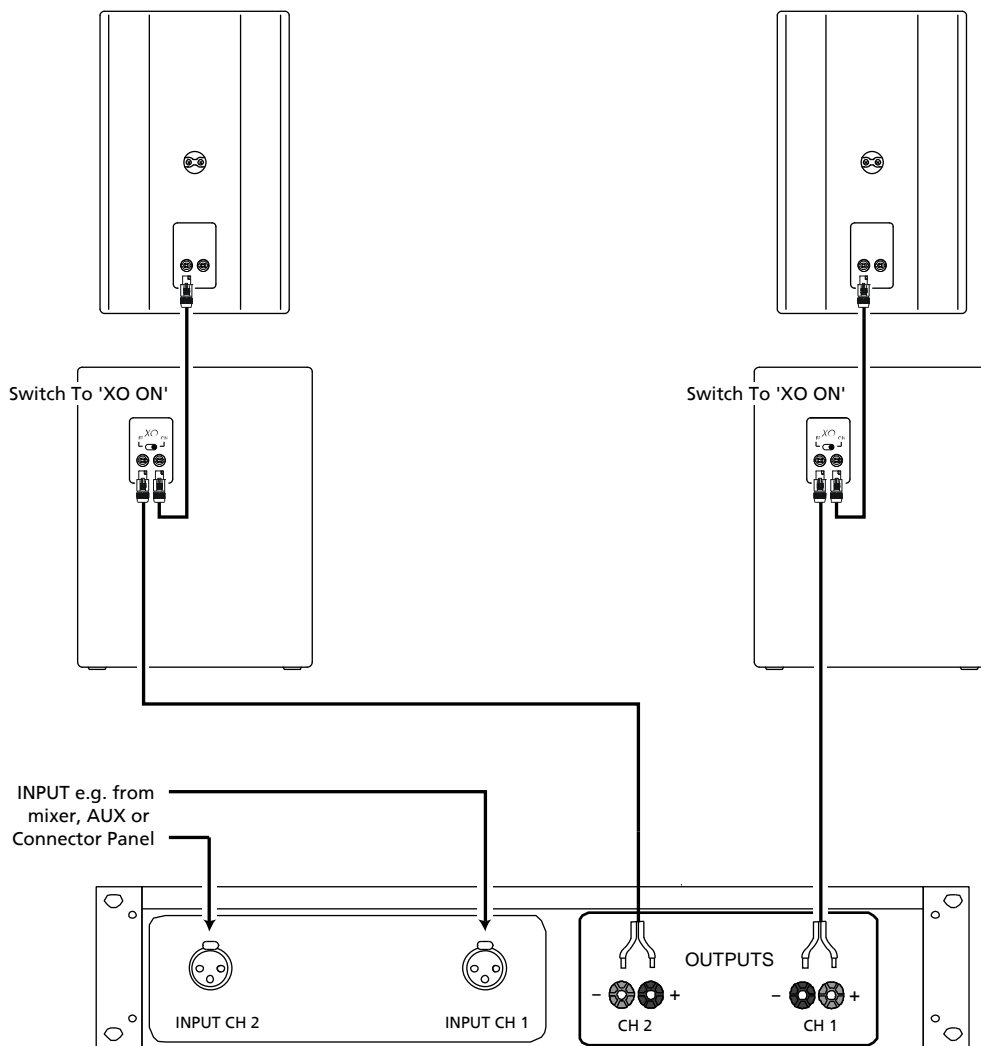

The switch 'XO' on the connecting terminal of the subwoofer must be at XO 'ON' for this mode of operation:

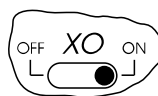

Switch on the subwoofer's connecting terminal

When using the mid-high systems in a cluster (speakers in close proximity), reduce the frequencies below 300 Hz by 3-4 dB. (The K&F System Controllers have a special 'Top Low Cut' filter function for this purpose.)

## 12.2 Operations with K&F System Controller

For optimal performance and operating safety we recommend using a K&F system controller. Instructions for use, connecting diagrams and detailed descriptions of the latest controller models 'CD 24' and 'CD 44' you can find in the corresponding user's manuals.

## 13. Operating the Speakers

- Switch off all equipment and turn down all level controls.
- Wire your CA systems.
- Pay attention to the user's manuals of your power amplifiers.
- Upon completing the wiring, ensure that the connected speaker channels are working in phase. To do so, use i.e. a phase checker. A phase error can also be recognized when the connected channels are used simultaneously. During simultaneous use the bass frequencies become notably quieter or the mid-frequencies such as voices cannot be located.
- Now switch on the peripheral equipment first (mixing console, effects etc.), followed by the K&F system controller, if used, and the power amplifiers. Always use the before mentioned switching order. Otherwise switching noises may damage the system.
- If there is interference, turn off all appliances in the reverse order and check all cable connections.
- Successively turn up the individual power amplifier channels and send a signal with low volume to the system. Check to see if the desired signals are applied to the intended speakers and make sure there is no interference. Make sure everything works properly, i.e. if the signals come from the correct speaker paths (high signals from the tweeters, bass signals from the bass speaker). Your system should now be ready for operation.
- Turning down the input level controls may not always prevent distortions in the input section of the power amplifier, especially if this section has a relatively low headroom. A clipping signal may not be displayed by the clipping indicator then. To prevent signal interruptions from protection circuits or damages to the speakers, turn the level controls of the power amplifier to the maximum position, if possible. The output level of the mixing console or the controller should be set to a level that doesn't overload the power amplifiers.
- When turning off the system, the input controls for the power amplifiers should be turned down first followed by the power switches of the amplifiers. After that, the other appliances can be turned off.
- The crossovers of the CA systems are equipped with protection circuits for the high frequency driver and the crossover itself. These circuits cut off the signal current when highly overloaded. If the high speaker turns off, reduce the volume. After a few seconds, it will turn back on automatically.

## 14. Crossovers

### 14.1 Wiring Diagram CA 1201

The crossover networks as of the end of 2003 differ from earlier models. Please compare the crossover built into your speaker with the figures below and wire accordingly:

#### 14.1.1 Version A

CA 1201 & CA 1201-M up to serial no. 231 0000 20 29 (by the end of October 03)

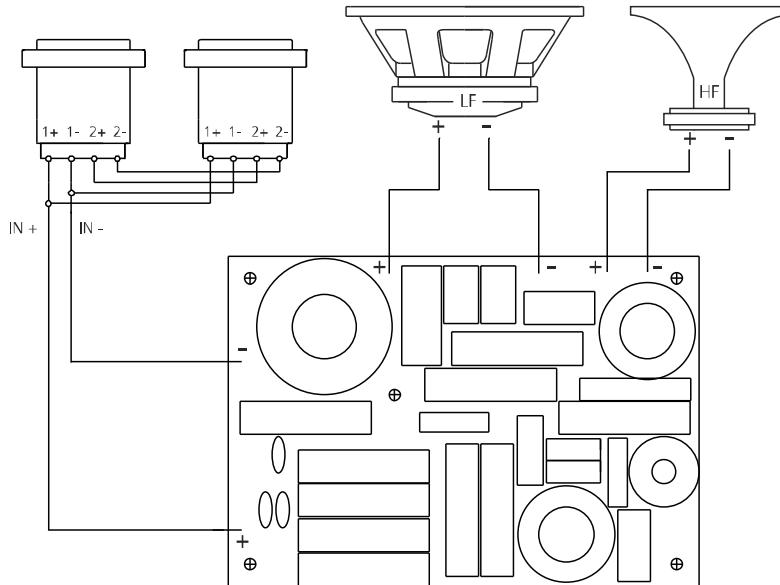

Pin assignment Speakon NL4				
	+	-	/	/
'IN'	1+	1-	2+	2-
'OUT'	parallel with 'IN'			

**14.1.2 Version B**

CA 1201 & CA 1201-M from serial no. 231 0000 20 30 (as of the end of October 03)

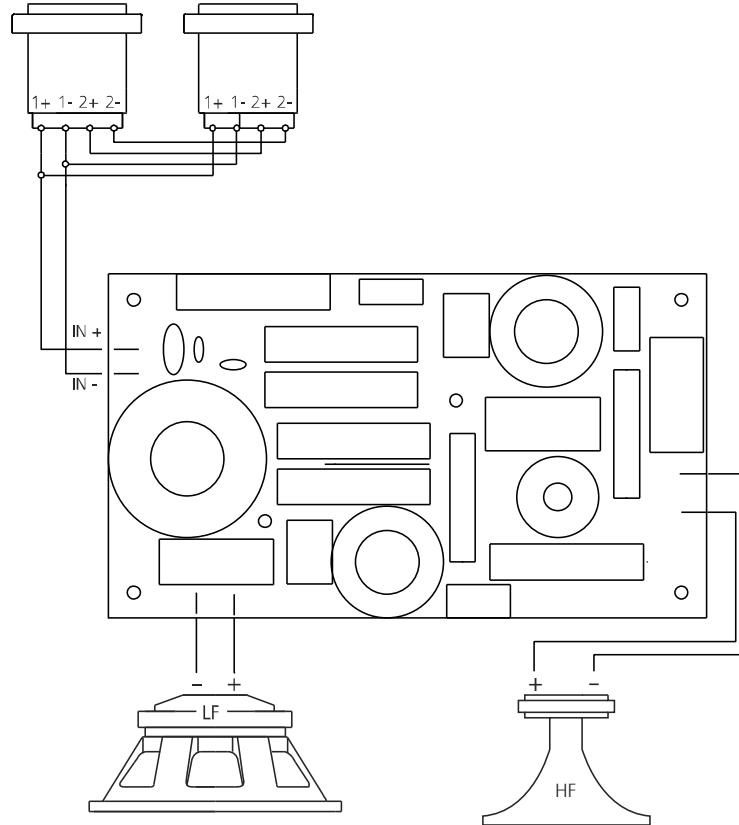

Pin assignment Speakon NL4				
	+	-	/	/
'IN'	1+	1-	2+	2-
'OUT'	parallel with 'IN'			

## 14.2 Wiring Diagram CA 1215-6 and CA 1215 -9

The crossover networks as of the end of 2003 differ from earlier models. Please compare the crossover built into your speaker with the figures below and wire accordingly.

### 14.2.1 Version A

CA 1215-6 and CA 1215-6-M up to serial number 23090007055 (before Sept. 03)

CA 1215-9 and CA 1215-9-M up to serial number 23090002675 (before Sept. 03)

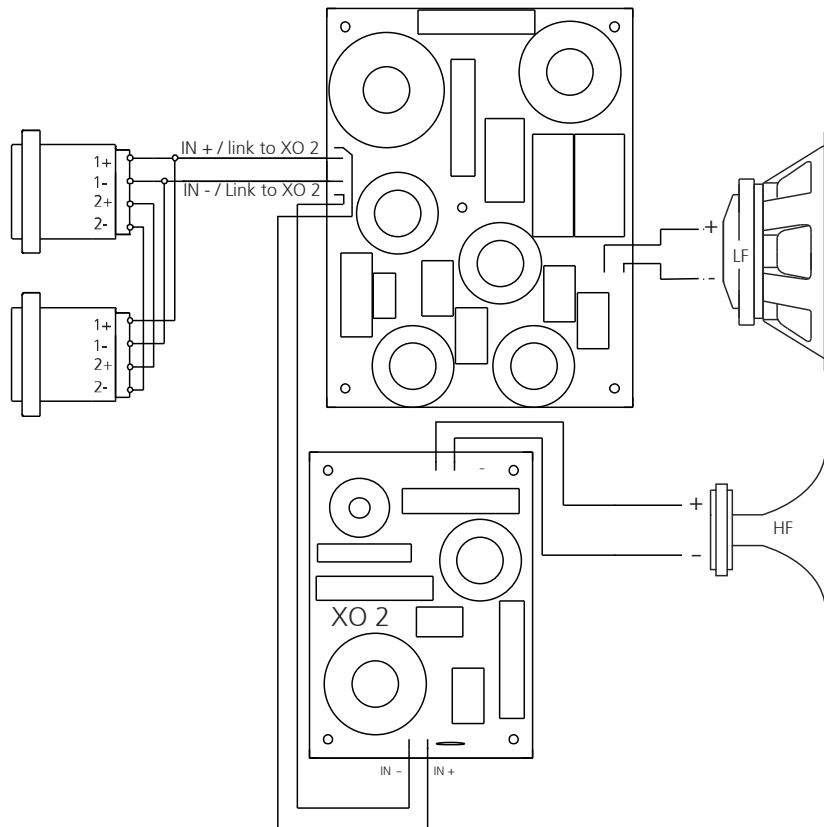

Pin assignment Speakon NL4				
	+	-	/	/
'IN'	1+	1-	2+	2-
'OUT'	parallel with 'IN'			

**14.2.2 Version B**

CA 1215-6 and CA 1215-6-M from serial number 23090007056 up (as of Sept. 03)

CA 1215-9 and CA 1215-9-M from serial number 23090002676 up (as of Sept. 03)

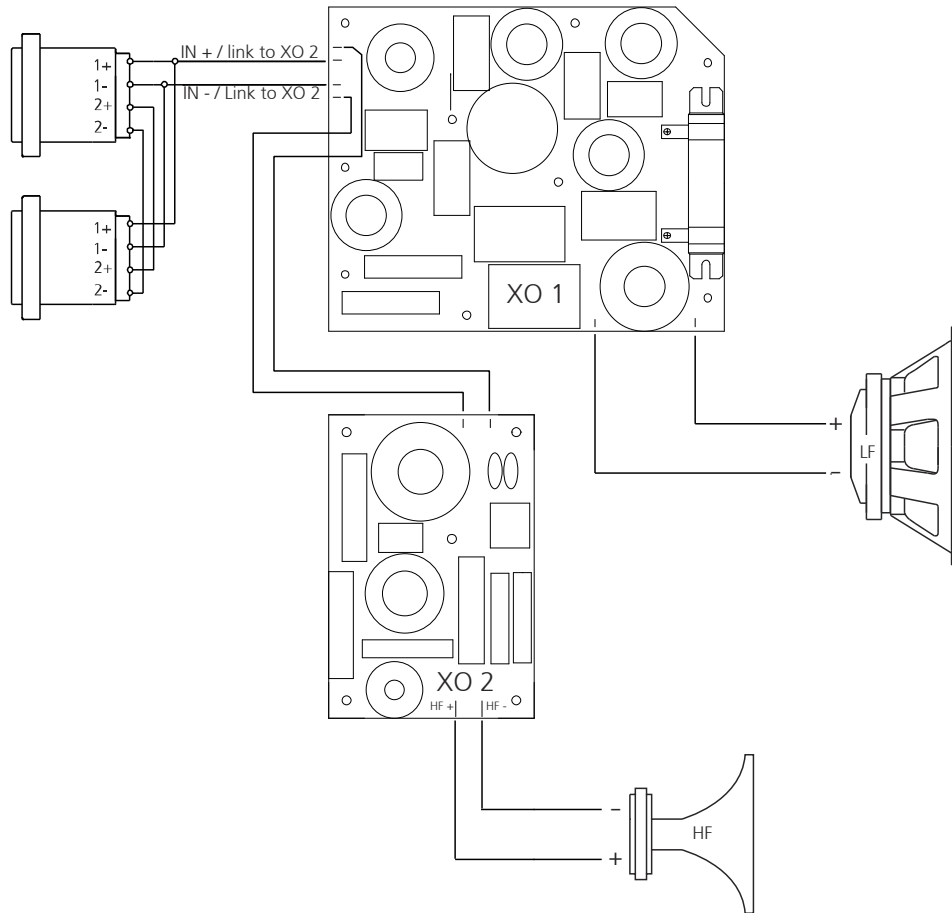

Pin assignment Speakon NL4				
	+	-	/	/
'IN'	1+	1-	2+	2-
'OUT'	parallel with 'IN'			

### 14.3 Wiring Diagram CA 1515-6 and CA 1515-9

The crossover networks as of the end of 2003 differ from earlier models. Please compare the crossover built into your speaker with the figures below and wire accordingly.

#### 14.3.1 Version A

CA 1515-6 and CA 1515-9 up to serial number 23116000434 (before November 03)

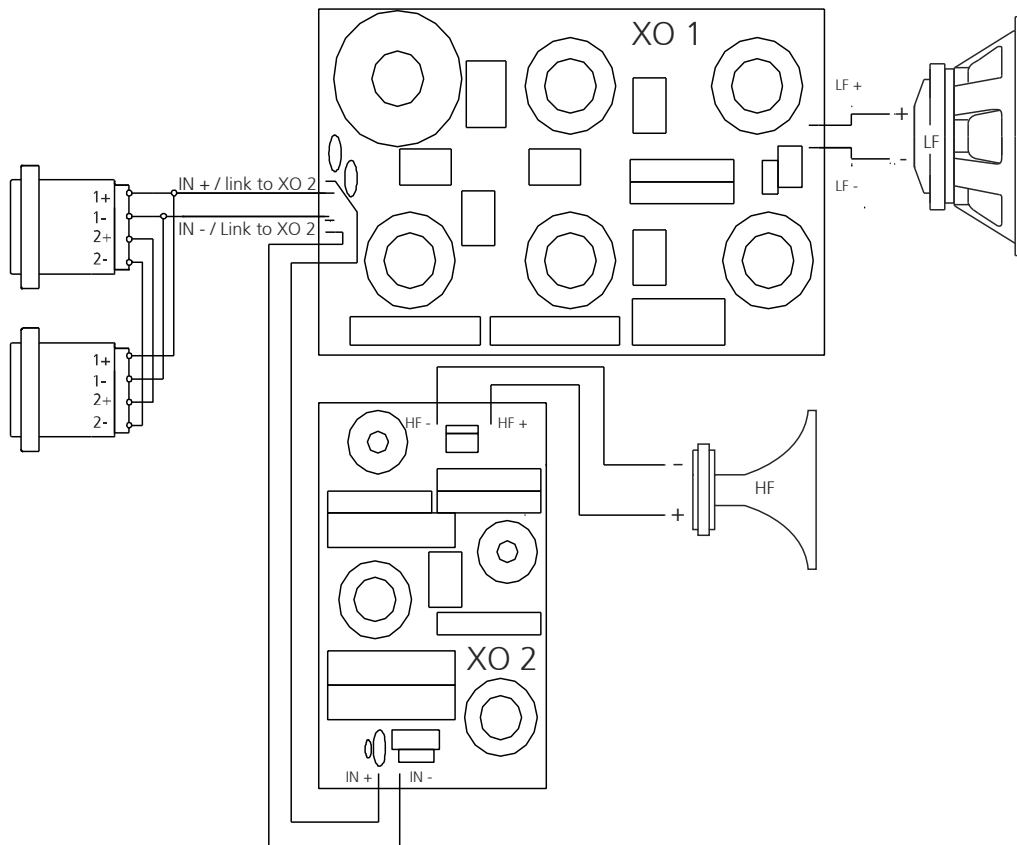

Pin assignment Speakon NL4				
	+	-	/	/
'IN'	1+	1-	2+	2-
'OUT'	parallel with 'IN'			

### 14.3.2 Version B

CA 1515-6 and CA 1515-9 from serial number 23116000435 (as of November 03)

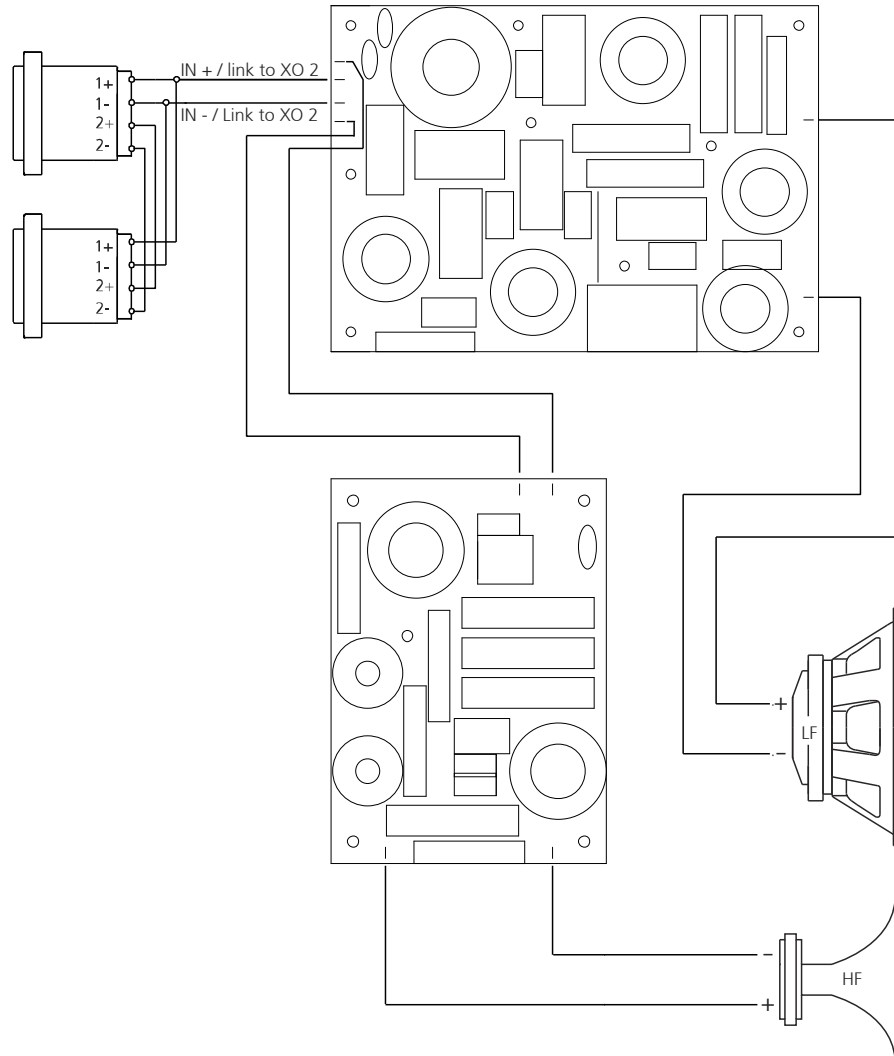

Pin assignment Speakon NL4				
	+	-	/	/
'IN'	1+	1-	2+	2-
'OUT'	parallel with 'IN'			

## 15. Touching Up Damage to Paint / Changing the Front Foam

Although the PU structured paint used by KLING & FREITAG is impact proof and extremely resistant, we recommend using protective coverings or cases to help avoid damaging the paint during i.e. continuous mobile use. If paint damage occurs despite these precautions, it can be touched up by using commercial acrylic paint in the appropriate RAL colour of the speaker.

To replace the filter foam, send the front grille incl. foam to KLING & FREITAG GmbH. Upon payment for expenses, the grille with the new covering will be returned.

## 16. Technical Specifications

### 16.1 CA 1201

Loudspeaker	
Design	2-way passive system, bass reflex tuning
Frequency range -10 dB	54 Hz - 19 kHz
Frequency range $\pm 3$ dB	65 Hz - 18 kHz
Coverage angles nominal	90° x 60° (hor. x vert.)
Directivity index (DI)	10 (+1.5/-1) 1.2 kHz - 16 kHz
Power handling	300 W nominal <sup>1)</sup>
Max. SPL	126 dB (SPL peak / 1 m)
Components	12" low-mid chassis 1" high freq. driver with 40 mm titanium dome on rotatable CD-horn
Crossover	1.8 kHz 18 dB / octave self-resetting protection circuits for 12" and 1" chassis
Impedance (nominal)	8 •
Connectors	2 x Speakon NL4MP (1+ / 1-)
Enclosure	
	Trapezoidal enclosure with additional cluster angles, 15 mm Finnish birch Multiplex with highly resistant black structured paint (PU), 2 butterfly handles, mounting flange K&M 19656, ball proof front grille with exchangeable black acoustic foam
Rigging	5 flying points 'allsafe JUNGFALK'
Dimensions (W x H x D)	380 x 605 x 375 mm
Weight	25 kg
Options	'48° monitor angle' (K&F CA 1201 - M) '100 Volt with 300 VA toroidal transformer' 'Barrier strip instead of Speakon connectors' 'Outdoor Mobile' and 'Outdoor Installation' 'Special finish in RAL colours'
Accessories	see catalogue or visit <a href="http://www.kling-freitag.de">www.kling-freitag.de</a>

## 16.2 CA 1215-6

Loudspeaker	
Design	2-way passive system, bass reflex tuning
Frequency range -10 dB	62 Hz - 22 kHz
Frequency range $\pm 3$ dB	84 Hz - 19 kHz
Coverage angles nominal	65° x 50° (hor. x vert.)
Directivity index (DI)	12 (+1.5/-2) 1.2 kHz - 16 kHz
Power handling	400 W nominal <sup>1)</sup>
Max. SPL	130 dB (SPL peak / 1 m)
Components	12" low-mid chassis 1.5" high freq. driver with 75 mm titanium dome on rotatable CD-horn
Crossover	1.2 kHz 12 dB / octave, self-resetting protection circuits for 12" and 1.5" chassis, all-pass filter for delay time and phase optimisation
Impedance (nominal)	8 •
Connectors	2 x Speakon NL4MP (1+ / 1-)
Enclosure	
	Trapezoidal enclosure with additional cluster angles, 15 mm Finnish birch Multiplex with highly resistant black structured paint (PU), 2 butterfly handles, mounting flange K&M 19656, ball proof front grille with exchangeable black acoustic foam
Rigging	5 flying points 'allsafe JUNGFALK'
Dimensions (W x H x D)	380 x 605 x 375 mm
Weight	31 kg
Options	'48° monitor angle' (K&F CA 1215-6 - M) '100 Volt with 300 VA toroidal transformer' 'Barrier strip instead of Speakon connectors' 'Outdoor Mobile' and 'Outdoor Installation' 'Special finish in RAL colours'
Accessories	see catalogue or visit <a href="http://www.kling-freitag.de">www.kling-freitag.de</a>

## 16.3 CA 1215-9

Loudspeaker	
Design	2-way passive system, bass reflex tuning
Frequency range -10 dB	58 Hz - 22 kHz
Frequency range $\pm 3$ dB	80 Hz - 19 kHz
Coverage angles nominal	90° x 50° (hor. x vert.)
Directivity index (DI)	10 (+2/-1) 1 kHz - 13 kHz
Power handling	400 W nominal <sup>1)</sup>
Max. SPL	129 dB (SPL Peak / 1 m)
Components	12" low-mid chassis 1.5" high freq. driver with 75 mm titanium dome on rotatable CD-horn
Crossover	1.2 kHz 12 dB / octave, self-resetting protection circuits for 12" and 1.5" chassis, all-pass filter for delay time and phase optimisation
Impedance (nominal)	8 •
Connectors	2 x Speakon NL4MP (1+ / 1-)
Enclosure	
	Trapezoidal enclosure with additional cluster angles, 15 mm Finnish birch Multiplex with highly resistant black structured paint (PU), 2 butterfly handles, mounting flange K&M 19656, ball proof front grille with exchangeable black acoustic foam
Rigging	5 flying points 'allsafe JUNGFALK'
Dimensions (W x H x D)	380 x 605 x 375 mm
Weight	31 kg
Options	'48° monitor angle' (K&F CA 1215-9 - M) '100 Volt with 300 VA toroidal transformer' 'Barrier strip instead of Speakon connectors' 'Outdoor Mobile' and 'Outdoor Installation' 'Special finish in RAL colours'
Accessories	see catalogue or visit <a href="http://www.kling-freitag.de">www.kling-freitag.de</a>

## 16.4 CA 1515-6

Loudspeaker	
Design	2-way passive system, bass reflex tuning
Frequency range -10 dB	47 Hz - 22 kHz
Frequency range $\pm 3$ dB	77 Hz - 19 kHz
Coverage angles nominal	65° x 50° (hor. x vert.)
Directivity index (DI)	12 (+1.5/-2) 1.2 kHz - 16 kHz
Power handling	500 W nominal <sup>1)</sup>
Max. SPL	132 dB (SPL peak / 1 m)
Components	15" low-mid chassis 1.5" high freq. driver with 75 mm titanium dome on rotatable CD-horn
Crossover	1.1 kHz 12 dB / octave, self-resetting protection circuits for speakers and crossover, all-pass filter for delay time and phase optimisation
Impedance (nominal)	8 •
Connectors	2 x Speakon NL4MP (1+ / 1-)
Enclosure	
	Multi-purpose enclosure with monitor and cluster angles, 15 mm Finnish birch Multiplex with highly resistant black structured paint (PU), 2 butterfly handles, mounting flange K&M 19656, ball proof front grille with exchangeable black acoustic foam
Dimensions (W x H x D)	433 x 680 x 410 mm
Weight	36.4 kg
Options	'100 Volt with 300 VA toroidal transformer' 'Barrier strip instead of Speakon connectors' 'Outdoor Mobile' and 'Outdoor Installation' 'Special finish in RAL colours'
Accessories	see catalogue or visit <a href="http://www.kling-freitag.de">www.kling-freitag.de</a>

## 16.5 CA 1515-9

Loudspeaker	
Design	2-way passive system, bass reflex tuning
Frequency range -10 dB	58 Hz - 22 kHz
Frequency range $\pm 3$ dB	75 Hz - 19 kHz
Coverage angles nominal	90° x 50° (hor. x vert.)
Directivity index (DI)	10 (+2/-1) 1 kHz - 13 kHz
Power handling	500 W nominal <sup>1)</sup>
Max. SPL	131 dB (SPL peak / 1 m)
Components	15" low-mid chassis 1.5" high freq. driver with 75 mm titanium dome on rotatable CD-horn
Crossover	1.1 kHz 12 dB / octave, self-resetting protection circuits for speakers and crossover, all-pass filter for delay time and phase optimisation
Impedance (nominal)	8 •
Connectors	2 x Speakon NL4MP (1+ / 1-)
Enclosure	
	Multi-purpose enclosure with monitor and cluster angles, 15 mm Finnish birch Multiplex with highly resistant black structured paint (PU), 2 butterfly handles, mounting flange K&M 19656, ball proof front grille with exchangeable black acoustic foam
Rigging	5 flying points 'allsafe JUNGFALK'
Dimensions (W x H x D)	433 x 680 x 410 mm
Weight	36.4 kg
Options	'100 Volt with 300 VA toroidal transformer' 'Barrier strip instead of Speakon connectors' 'Outdoor Mobile' and 'Outdoor Installation' 'Special finish in RAL colours'
Accessories	see catalogue or visit <a href="http://www.kling-freitag.de">www.kling-freitag.de</a>

# 17. Measuring Charts

## 17.1 CA 1201

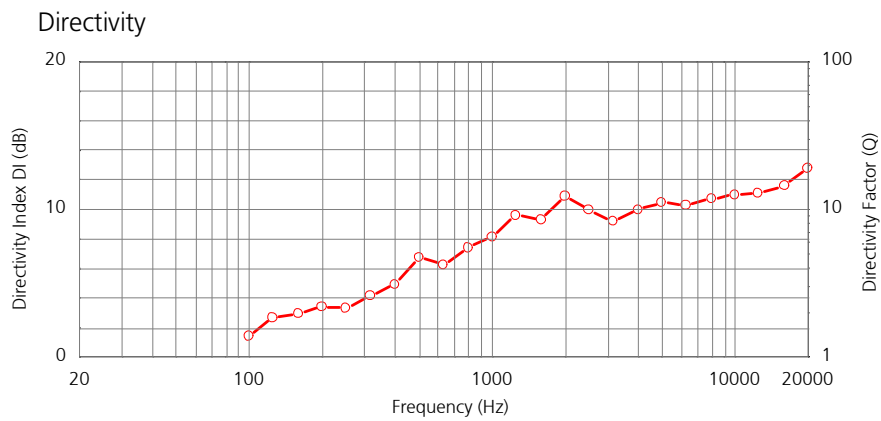
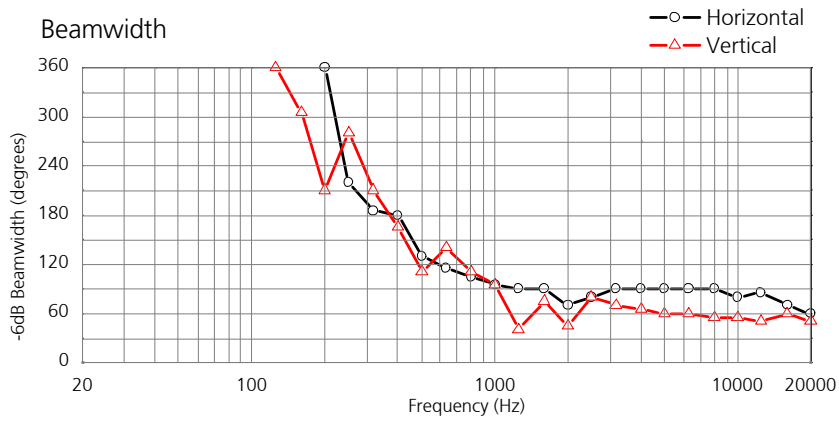
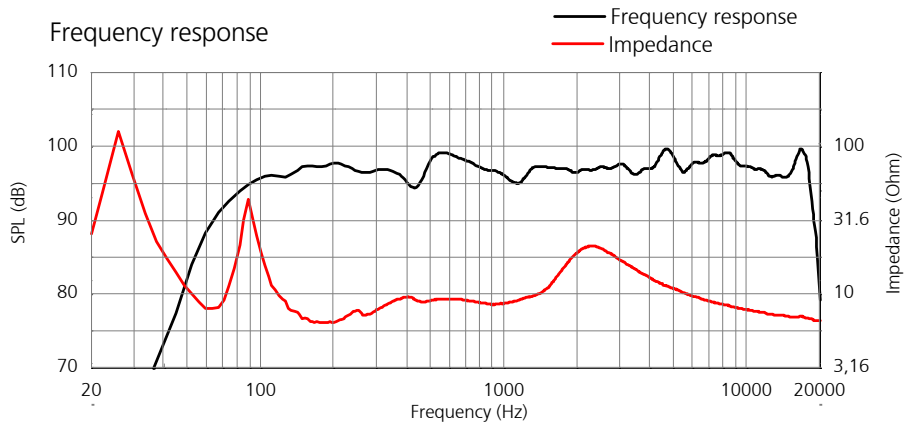

Horizontal coverage

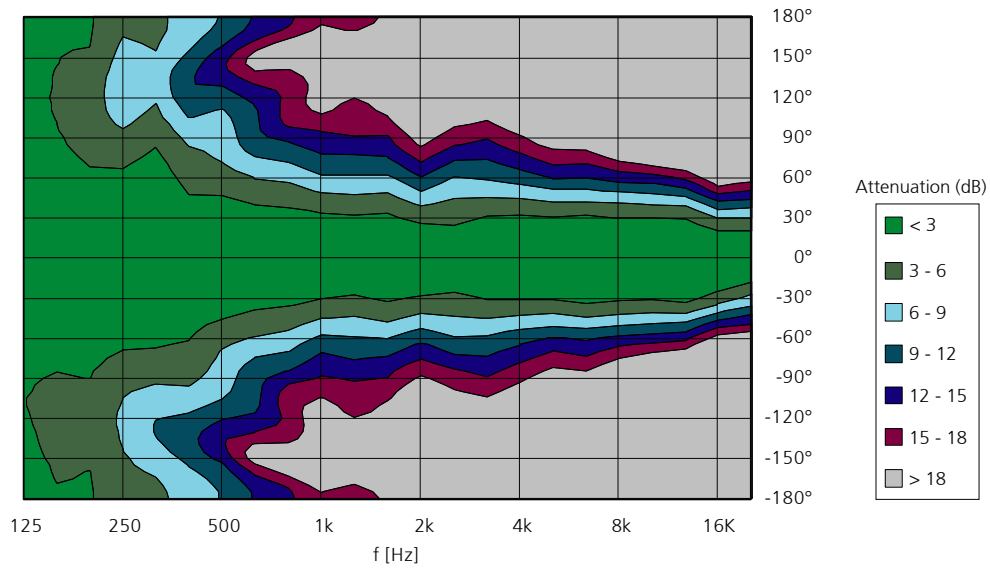

Vertical coverage

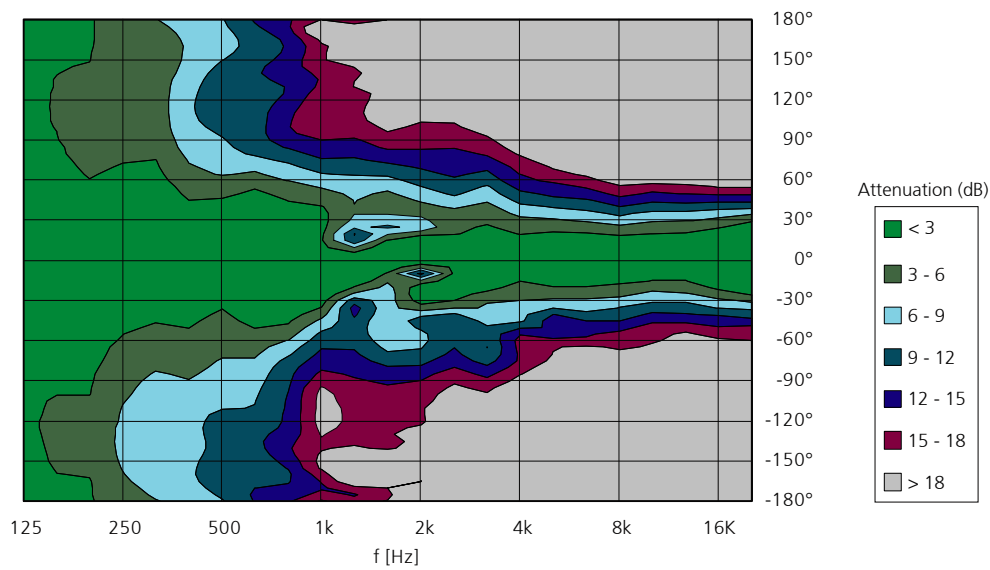

17.2 CA 1215-6

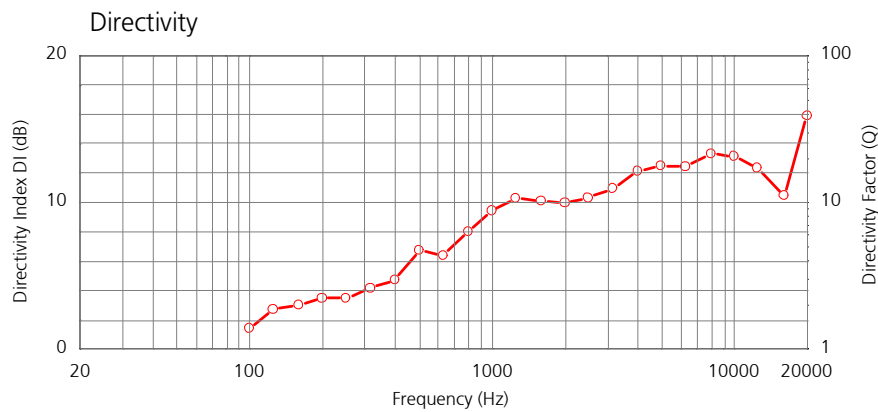
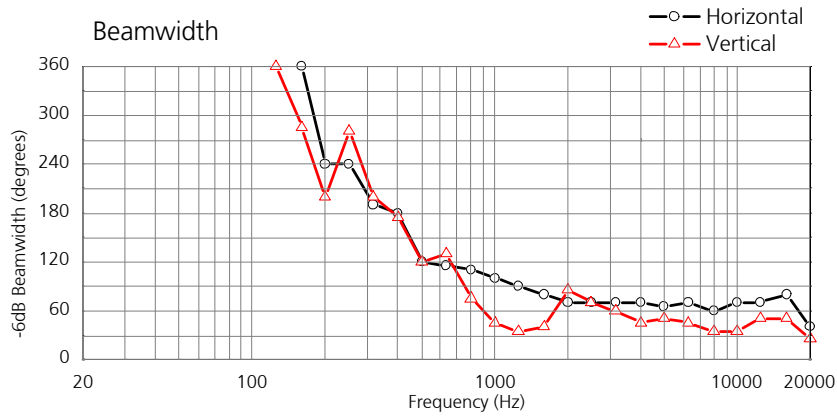
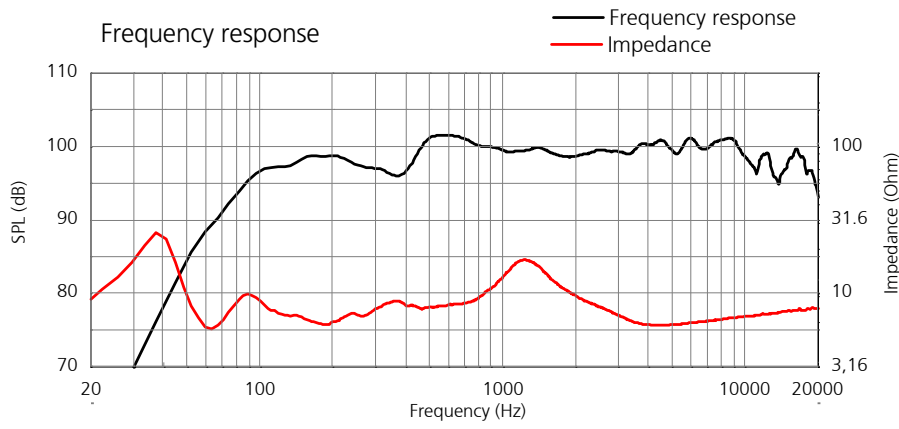

Horizontal coverage

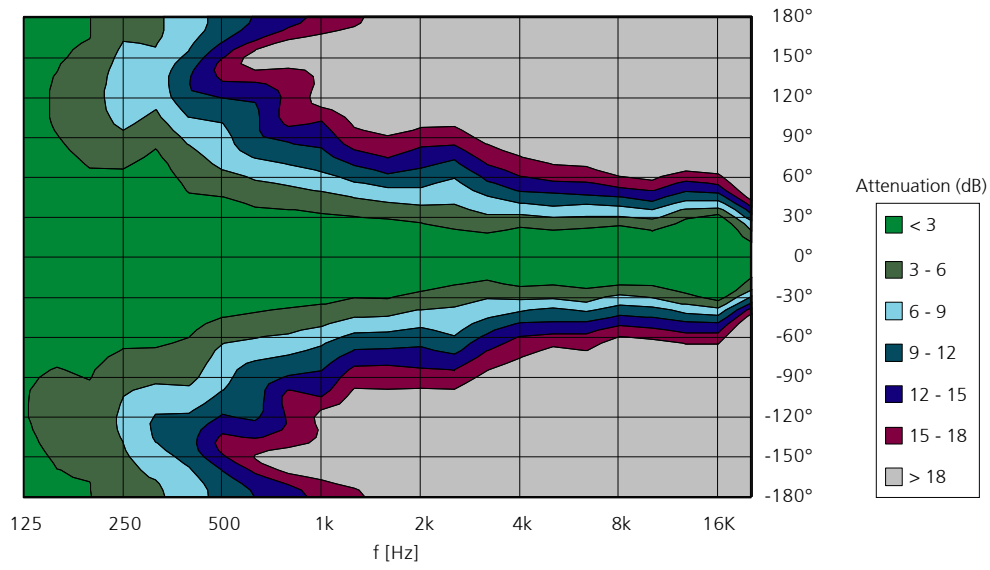

Vertical coverage

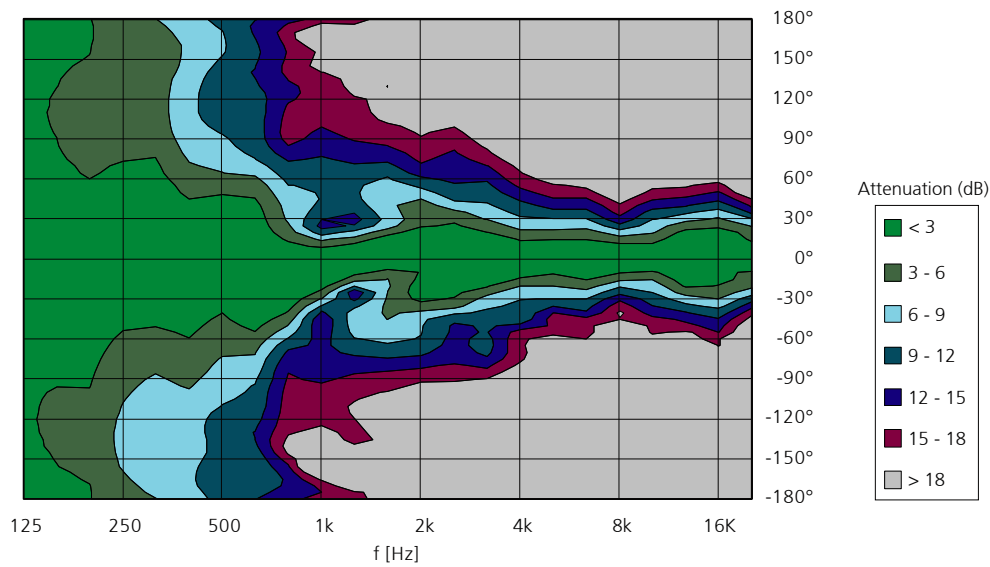

**17.3 CA 1215-9**

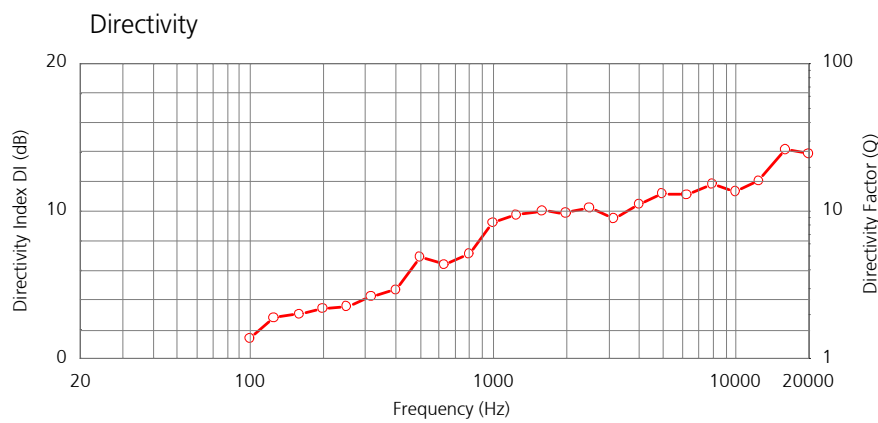
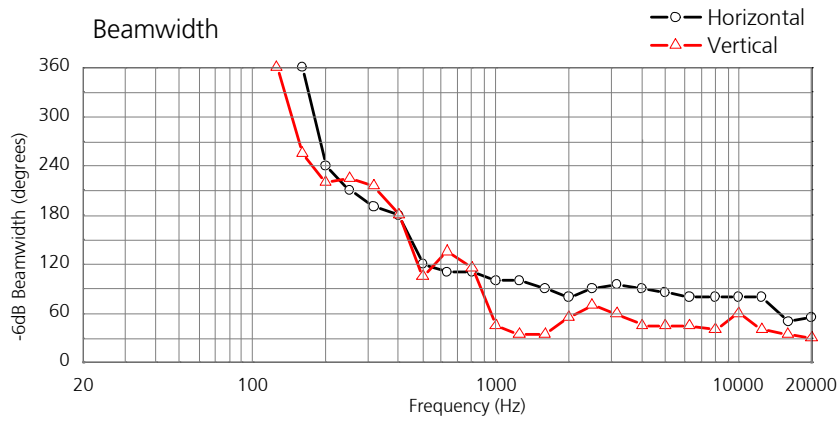
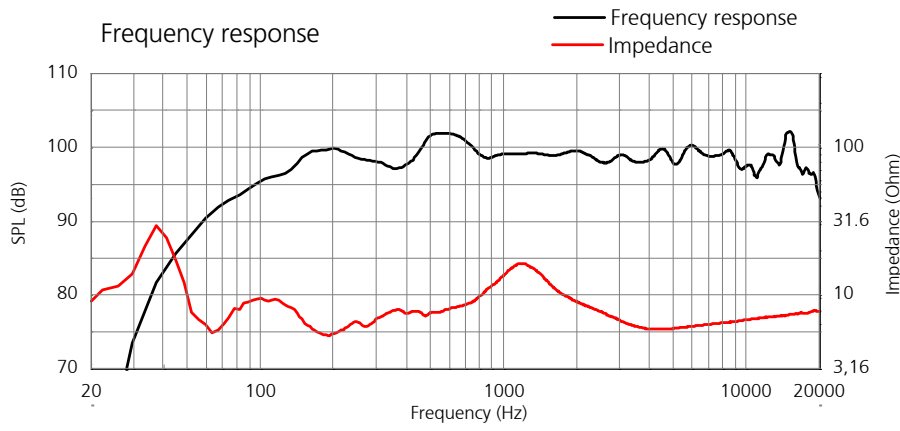

Horizontal coverage

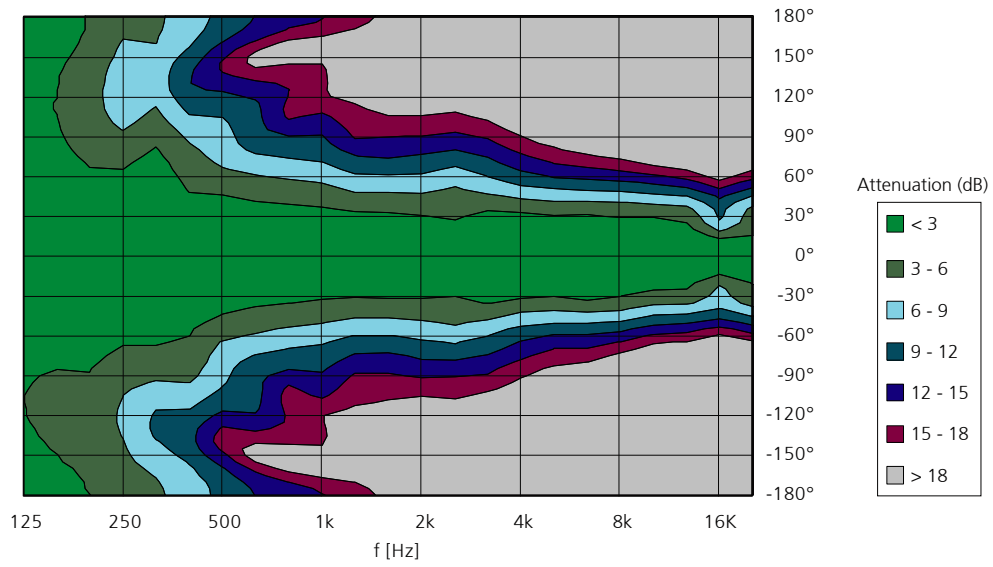

Vertical coverage

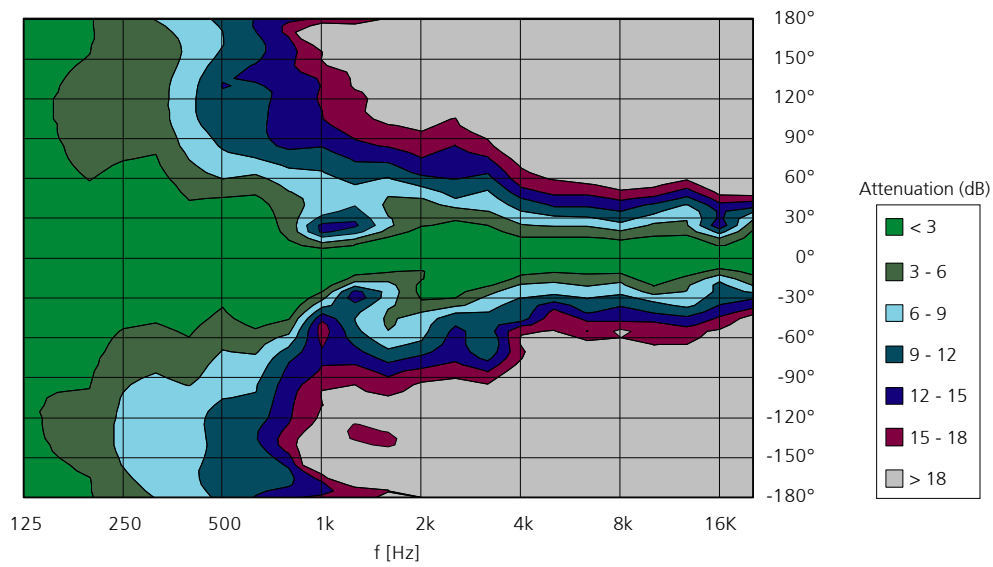

**17.4 CA 1515-6**

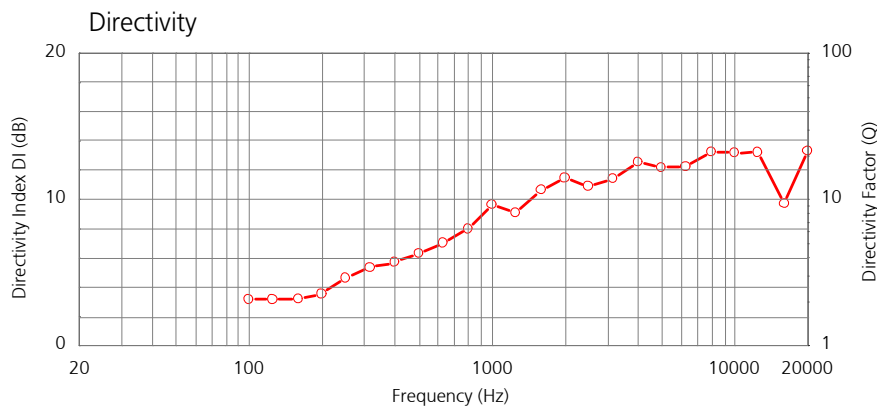
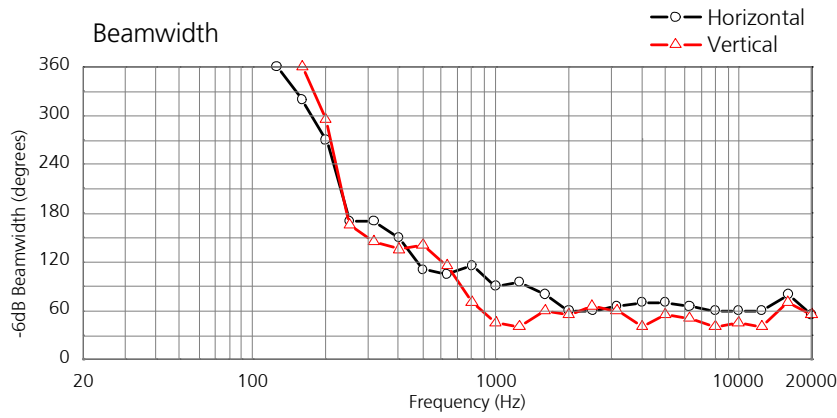
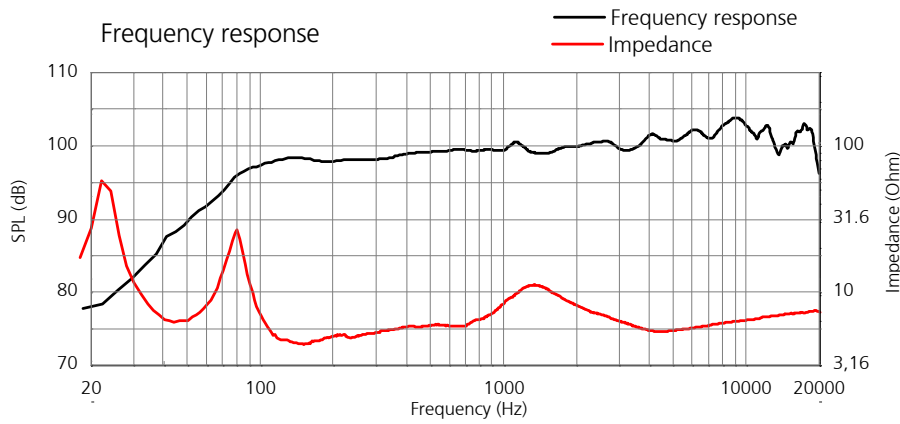

Horizontal coverage

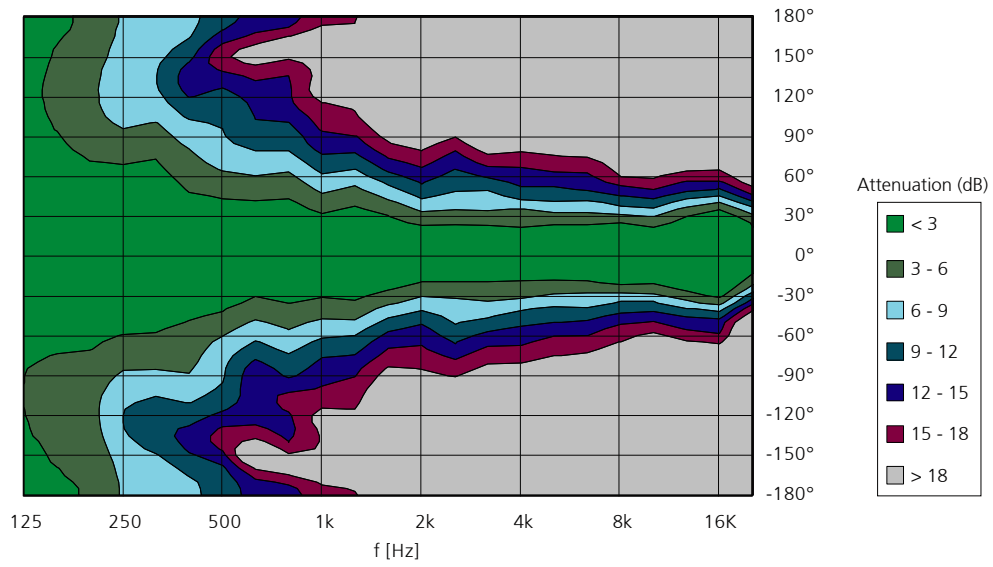

Vertical coverage

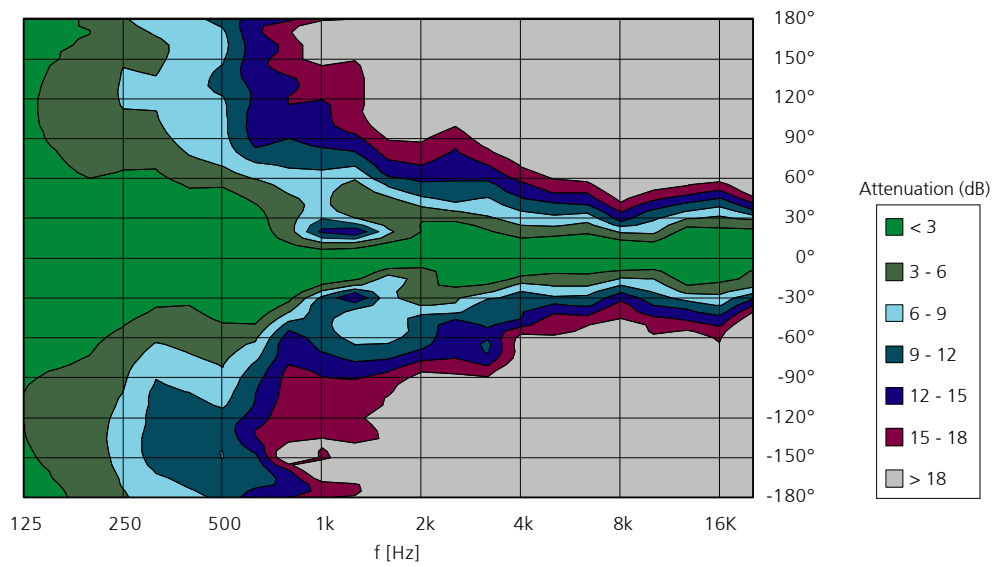

**17.5 CA 1515-9**

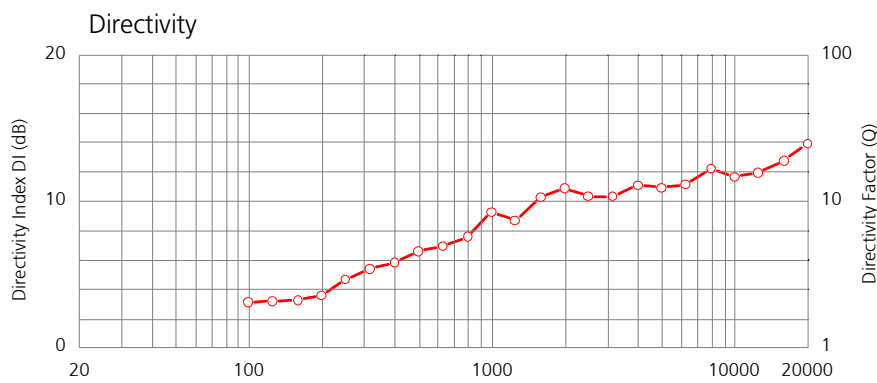
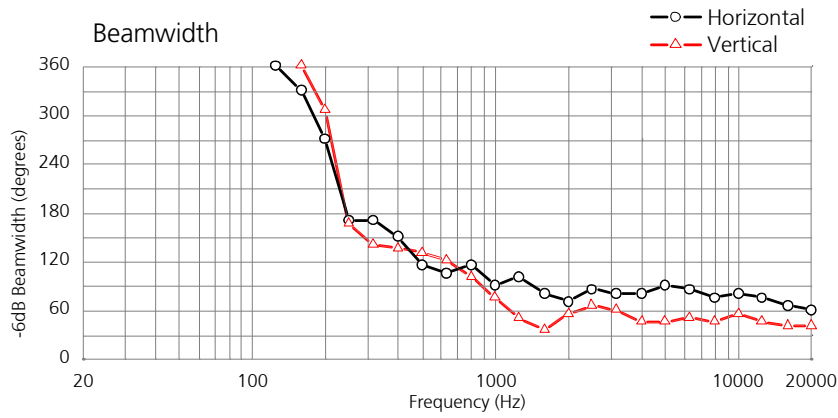
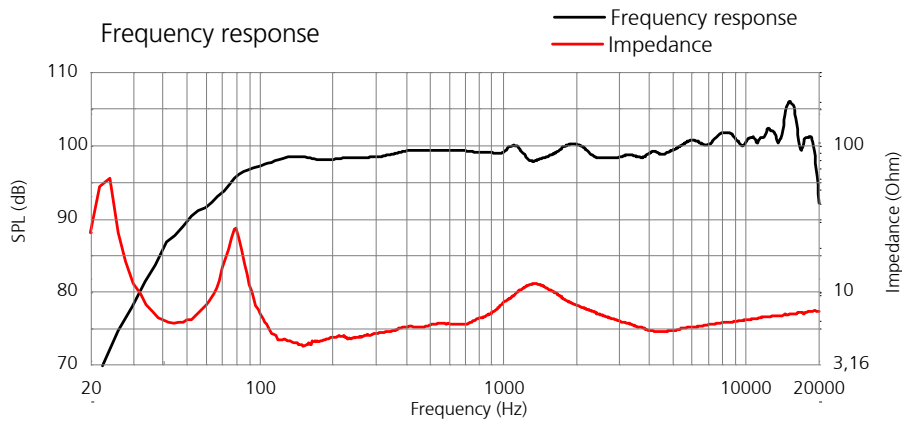

Horizontal coverage

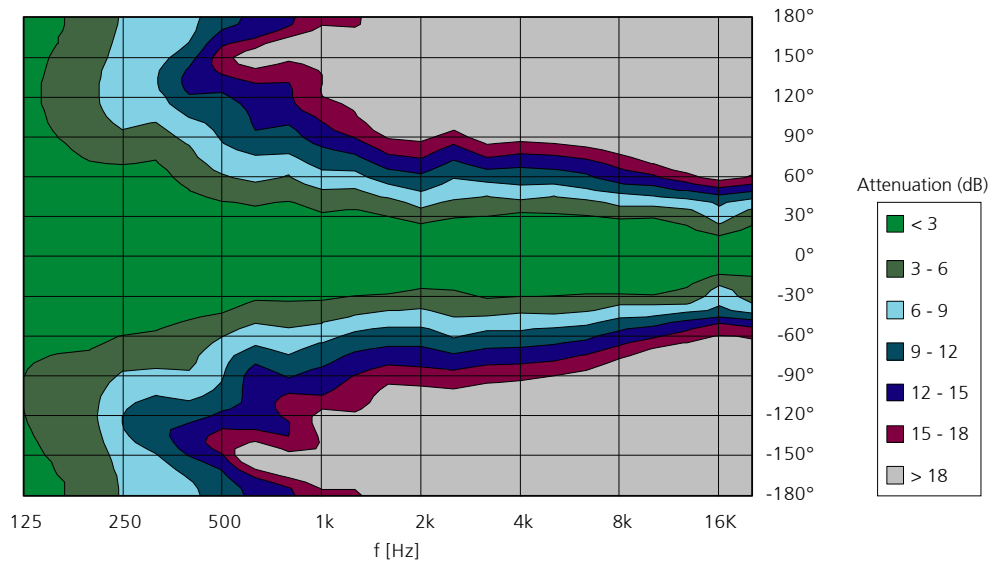

Vertical coverage

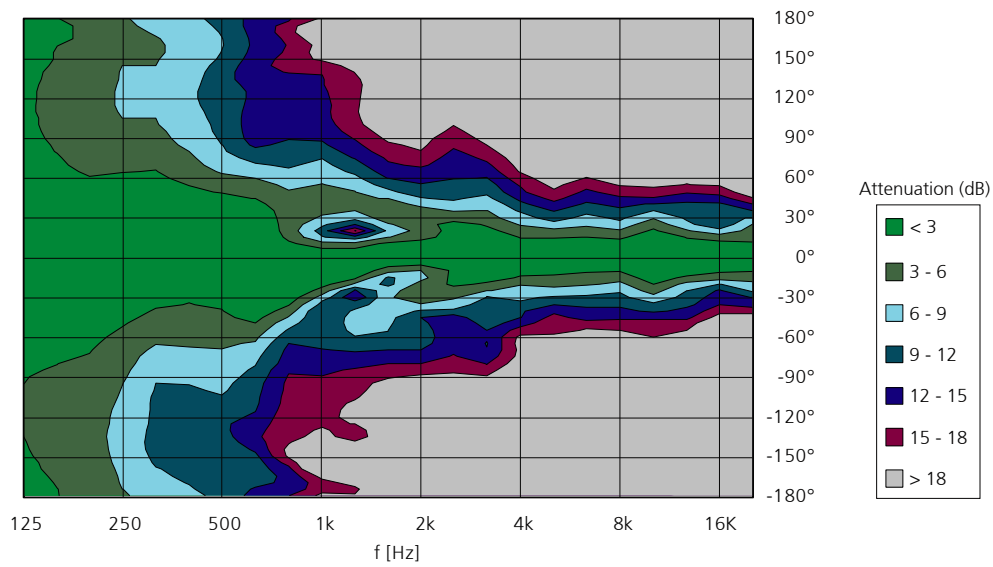

## 18. Dimensions

### 18.1 CA 1201, CA 1215-6 and CA 1215-9

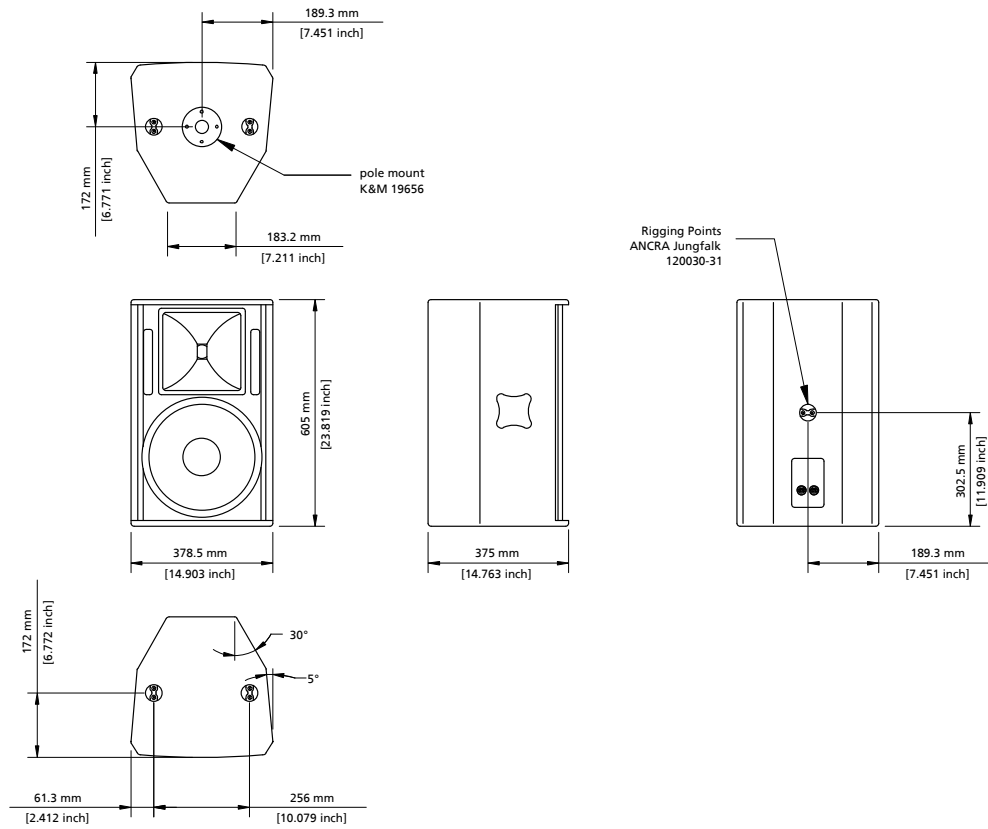

**18.2 CA 1201-M, CA 1215-6-M and CA 1215-9-M**

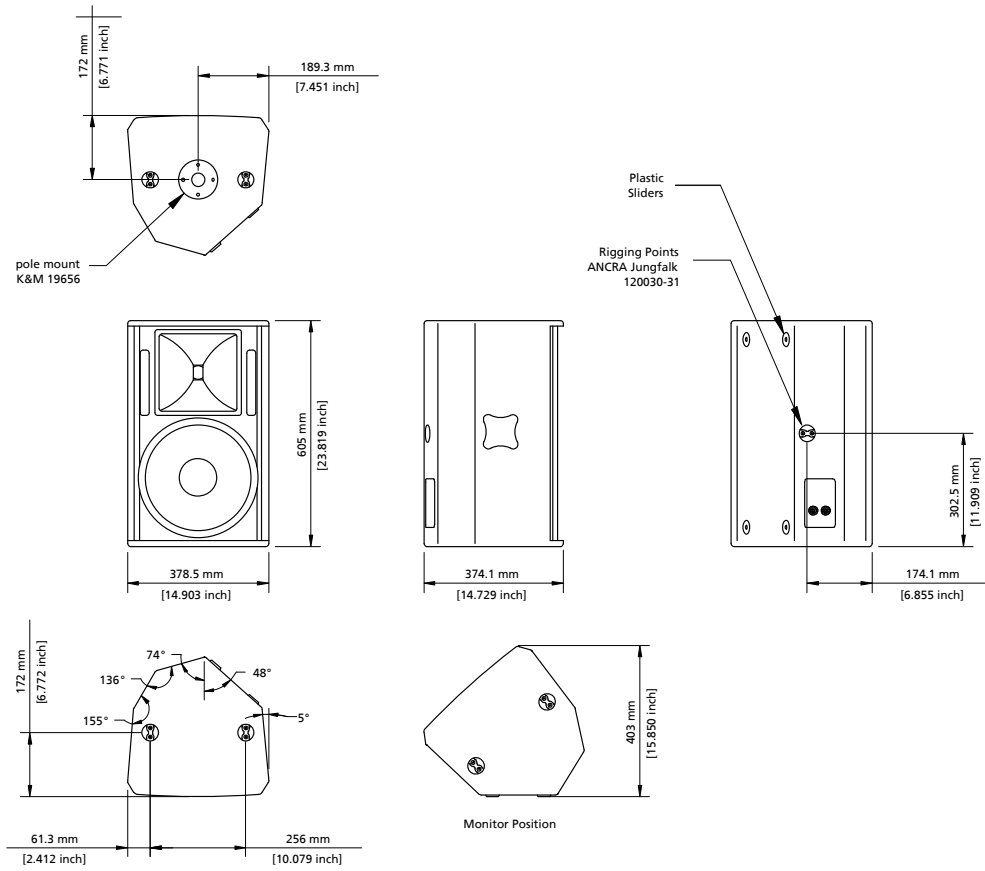

**18.3 CA 1201, CA 1215-6 and CA 1215-9 with Option 'Installation'**

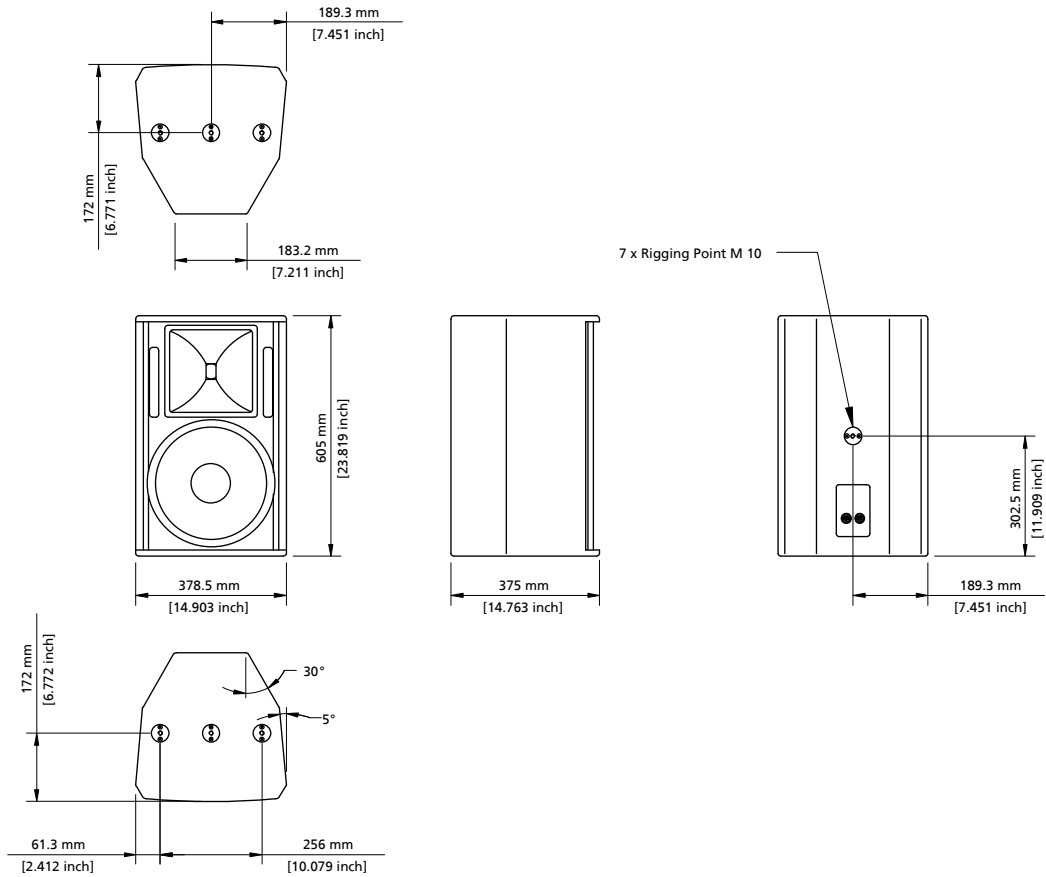

**18.4 CA 1515-6 and CA 1515-9**

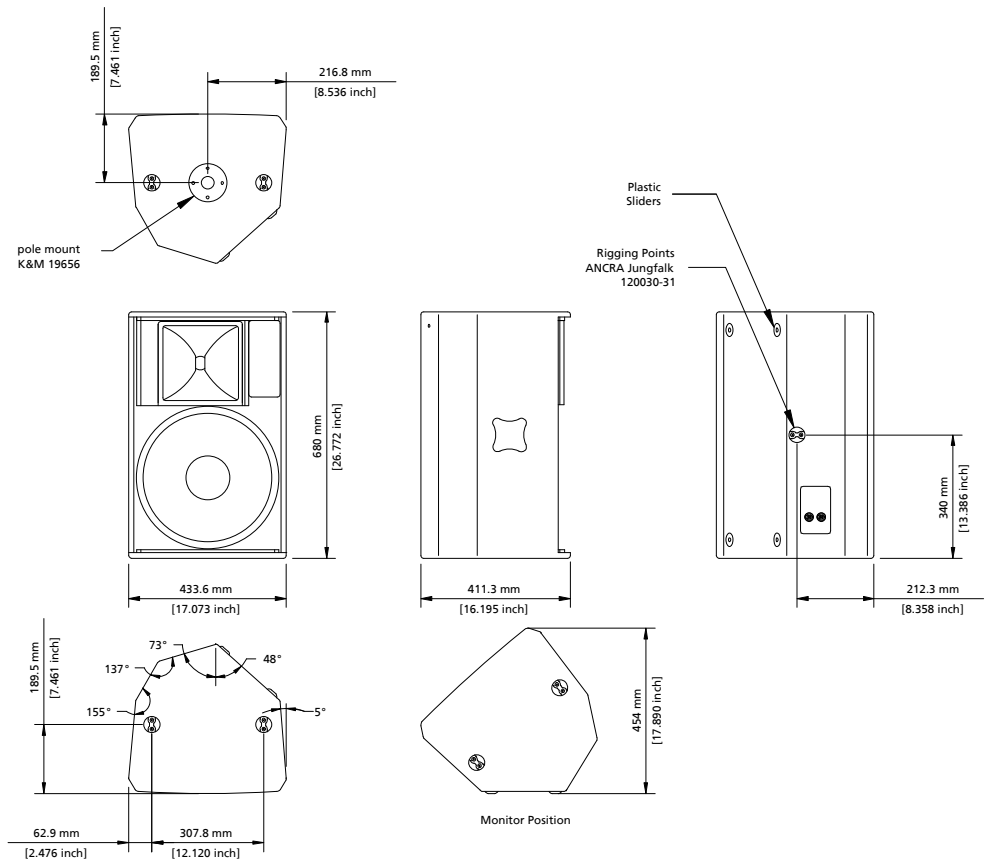

**18.5 CA 1515-6 and CA 1515-9 with Option 'Installation'**

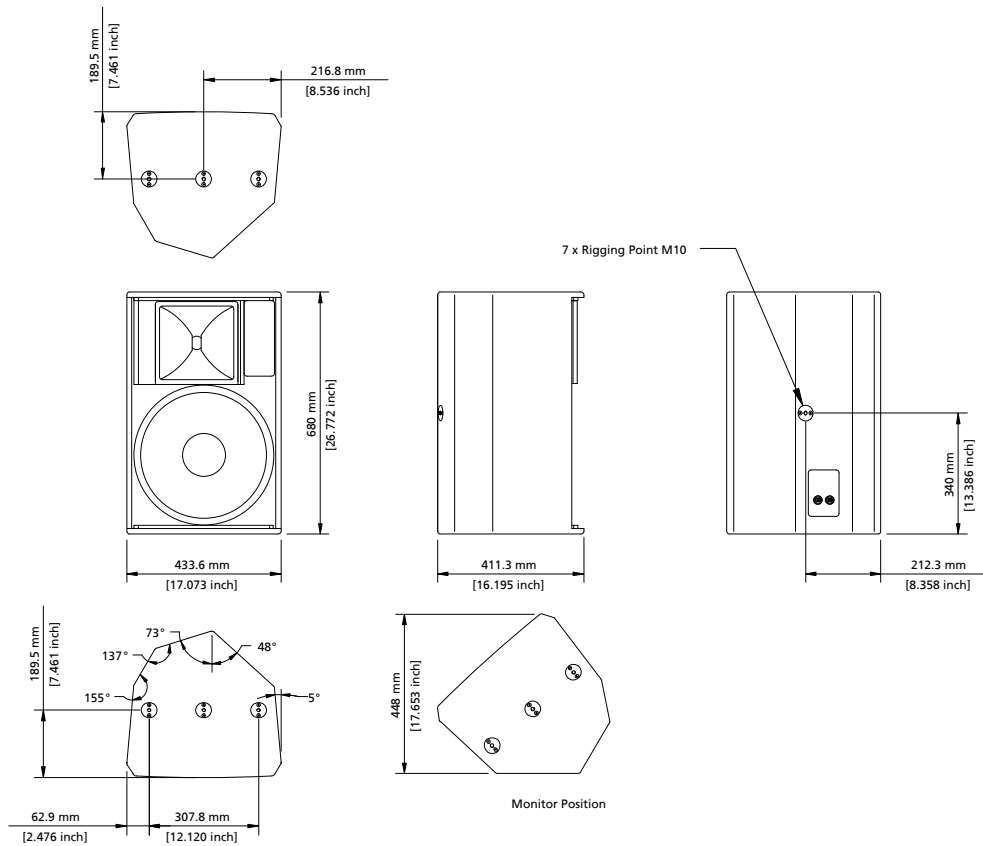

## 18.6 Accessories for the CA Systems

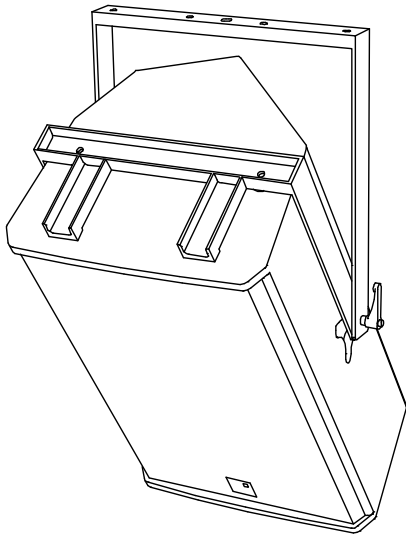

Tilt bracket CA 1201/CA1215  
CA 1515

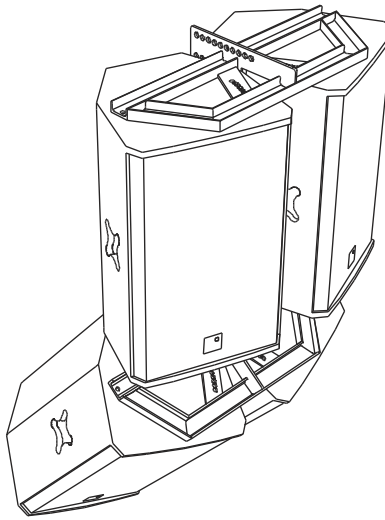

Cradle 1201/CA1215  
Cradle 1515

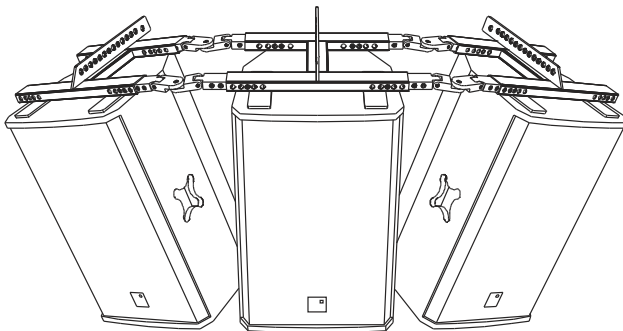

Multi Cradle CA 1201/CA1215  
Multi Cradle CA 1515

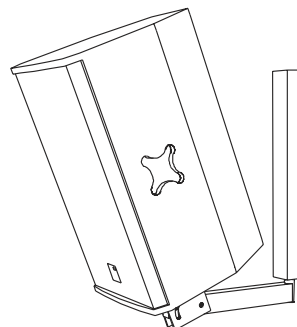

Wall mount,  
tiltable up to 50 kg

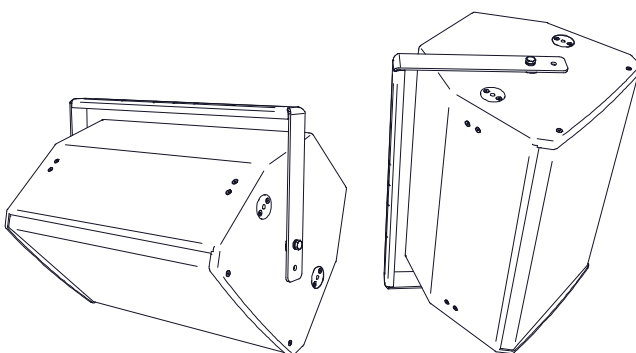

Mounting bracket for versions with option 'Installation'

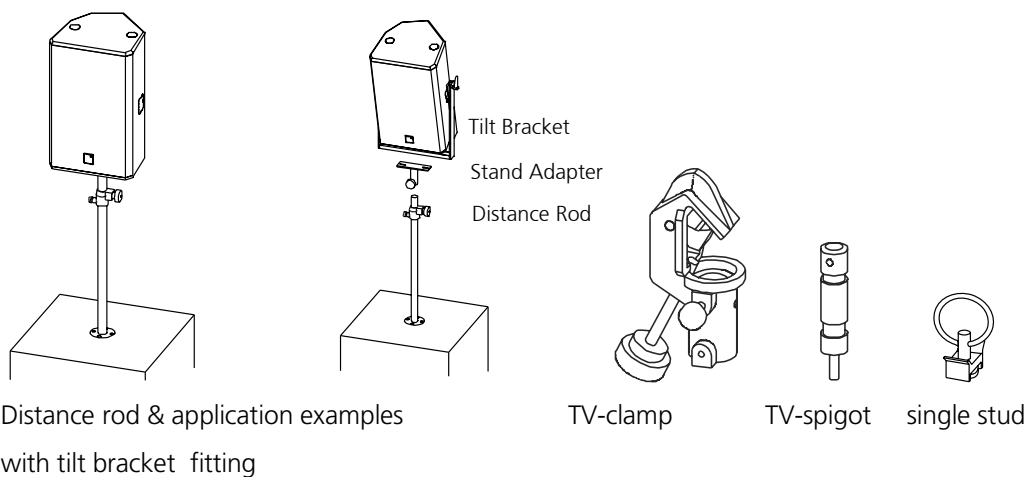

Further information is available in our downloadable catalogue at:

## 19. Disposal

Please recycle the packaging material of the device.

### 19.1 Germany

**It is not allowed to dispose of used electrical equipment as domestic waste.**

**But please do not dispose of them at official collecting points for recycling either!**

All KLING & FREITAG products are plain business-to-business (B2B) products. KLING & FREITAG products labelled with a waste bin sign have thus to be disposed of by KLING & FREITAG GmbH alone. Please call KLING & FREITAG at the number stated below if you have a KLING & FREITAG product to be disposed of. We will offer you a straightforward and professional disposal with no costs involved.

If there is no waste bin sign on one of your KLING & FREITAG products, because it has been sold before 24 March 2006, then by law the owner is in charge of the disposal. In this case we will be happy to assist and offer you proper ways of disposal.

**Telephone number to call about the disposal of used KLING & FREITAG products:**

**+49 (0) 511-96 99 7-0**



Explanation: With the ElektroG (law relating to electrical and electronic equipment and appliances) we have complied with the EU-directive on waste electrical and electronic equipment (WEEE, 2002/96/EC).

E From 03/24/2006 onwards KLING & FREITAG GMBH has thus labelled all products mentioned in the WEEE with a sign with a crossed out waste bin and a white bar below. This sign indicates that the disposal as domestic waste is prohibited and that the product has been put into circulation on 03/24/2006 at the earliest.

KLING & FREITAG GMBH has been legally registered as a manufacturer with the German registration office EAR. Our WEEE registration number is: DE64110372.

For the German Registration office EAR we have accredited that our products are soleB2B products.

### 19.2 EU, Norway, Iceland, and Liechtenstein

It is not allowed to dispose of used electrical equipment as domestic waste.



From 08/13/2005 onwards KLING & FREITAG GMBH has thus labelled all products for EU-Member countries as well as Norway, Iceland and Liechtenstein (except Germany) mentioned in the WEEE with a sign with a crossed out waste bin and a white bar below.

E This sign indicates that the disposal on domestic waste is prohibited and that the product has been put into circulation on 08/13/2005 at the earliest.

Unfortunately the European directive WEEE has been complied with implementing different national provisions of law throughout all member countries, which makes it impossible for us to offer consistent solutions for the disposal throughout Europe.

Responsible for complying with these provisions of law is the local distributor (importer) of each country.

For proper disposal of used products in accordance with these local provisions in the mentioned countries of the European Union (except Germany) please ask your local dealer or the local authorities.

### 19.3 All other Countries

For proper disposal of used products in accordance with local provisions in other than the above mentioned countries please ask your local dealer or the local authorities.