

Self Powered

LINE 212-6 - SP / LINE 212-9 - SP

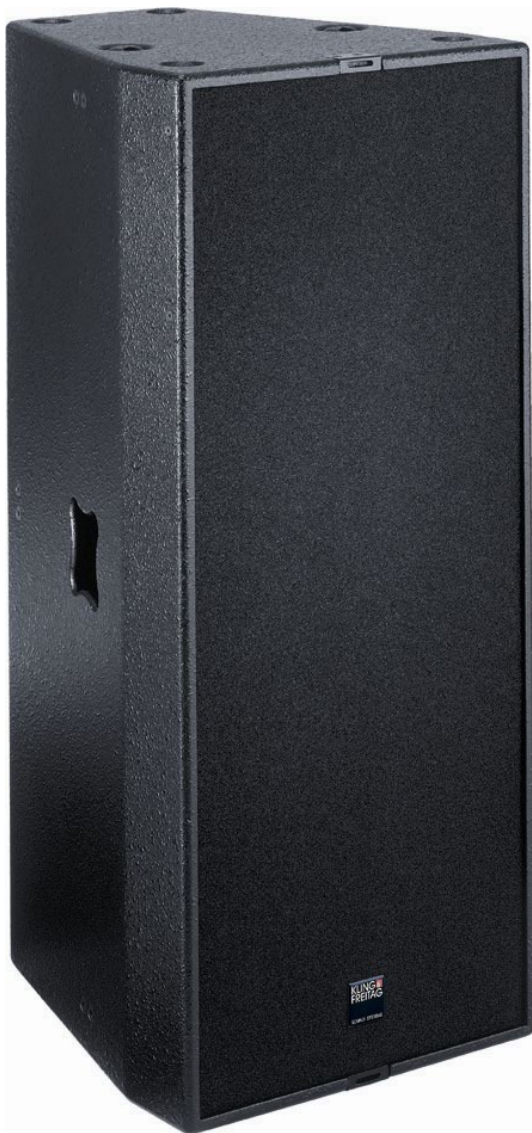
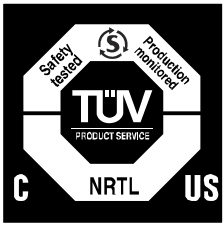

## User's Manual

Version 5.1  
Released: 09.09.2014



**Important Information,  
Please Read Before Use!**

KLING & FREITAG GmbH  
Junkersstrasse 14  
D-30179 Hannover  
PHONE 0 (049) 511- 969 97-0  
FAX 0 (049) 511- 67 37 94  
[www.kling-freitag.de](http://www.kling-freitag.de)





Thank you for your decision to buy a Kling & Freitag product. To guarantee a trouble-free operating of the equipment and to allow the KLING & FREITAG – 'SP' speaker system to achieve its full potential please read the operating instructions carefully before use.

With the purchase of a LINE 212 – SP system with integrated power amplifier technology, you have acquired a speaker system with the highest possible quality and performance capabilities.

As the owner of this system, you now have a versatile and highly professional tool which, when operated properly, is a true pleasure to use.

## Symbols in User's Manual



This symbol indicates the possibility of life-threatening danger and a health risk for persons. Not following these instructions may result in serious health problems including potentially fatal injuries.



This symbol indicates a possibly dangerous situation. Not following these instructions may cause minor injuries or cause property damage.



This symbol gives instructions for the proper use of the described products. Not following these instructions may cause malfunctions or property damage.

## Information about this User's Manual

User's Manual K&F LINE 212-6 - SP / LINE 212-9 - SP, Version 5.0, 09.09.2014

© by André Figula, Kling & Freitag GmbH, 2003 - 2014; all rights reserved.

All specifications in this manual are based on information available at the time of publishing for the features and safety guidelines of the described products.

Technical specifications, measurements, weights and properties are not guaranteed.

The manufacturer reserves the right to make product alterations within legal provisions as well as changes to improve product quality.

**All persons who use the speaker system must have this guide and all further information for safe operations available to them during assembly, disassembly, and use.**

We appreciate any input with suggestions and improvements for this manual.

Please send this to us at the following address:

info@kling-freitag.de or to:

KLING & FREITAG GMBH, Junkersstr.14, D-30179 Hannover

Phone +49 (0) 511 - 96 99 70, Fax +49 (0) 511 - 67 37 94

## Contents

Chapter	Page
1. General Safety Instructions	5
2. Introduction SP Loudspeakers	7
3. Connectors, Controls und Displays	9
4. Power Cord	13
5. Rigging Instructions for Line 212 Systems	14
5.1 Vertical Suspension	14
5.2 Horizontal Suspension	15
6. Using the 'allsafe JUNGFALK' Flying Points	16
7. Using the Rear Mounted 'allsafe JUNGFALK' Flying Track	17
7.1 Mounting the Single Stud Fittings	17
7.2 Mounting the Double Stud Fitting	18
8. Coverage Pattern of the Line 212 – SP Systems	19
8.1 Changing the Coverage Pattern	19
9. Mounting Instructions for Speakers	20
9.1 Proper Arrangement of the Loudspeakers	20
9.2 Arrayed Speaker Systems (Cluster)	21
9.3 LINE 212 Systems on Top of SW 215E	22
10. Wiring	23
10.1 Avoiding Ground Loops	23
10.1.1 What is a Ground Loop?	23
10.1.2 Avoiding Ground Loops	23
10.2 Connecting the Power Connectors to the Connecting Terminal	24
11. Configurations and Connecting Diagrams	25
11.1 Operating the Systems without K&F System Controller	25
11.1.1 Full-Range Mode	25
11.1.2 Full Range Mode with Subwoofer	26
11.2 Operating the Systems with K&F System Controller	27
11.3 Maximum Configuration	27
12. Operating the Speakers	28
13. Touching Up Damage to Paint / Changing the Front Foam	28
14. Block Diagram LINE 212 - SP	29
15. Technical Specifications	30
15.1 LINE 212-6 - SP	30
15.2 LINE 212-9 - SP	32
16. Measuring Charts	33
16.1 LINE 212-6 - SP	33
16.2 LINE 212-9 - SP	35
17. Dimensions	37
18. Accessories for the LINE 212 System	38
19. Regulations for Disposal	39
19.1 Germany	39
19.2 EU, Norway, Iceland, and Liechtenstein	39
19.3 Other Countries	39
20. Declaration of Conformity and International Certificates	40
20.1 Declaration of Conformity	40
20.2 EMV Certificate Directive 89 / 336 / EWG	41
20.3 TÜV Certificatefor USA und Canada (UL 6500)	43
21. Included Instructions for Loudspeakers and Mounting Accessories	

## 1. General Safety Instructions

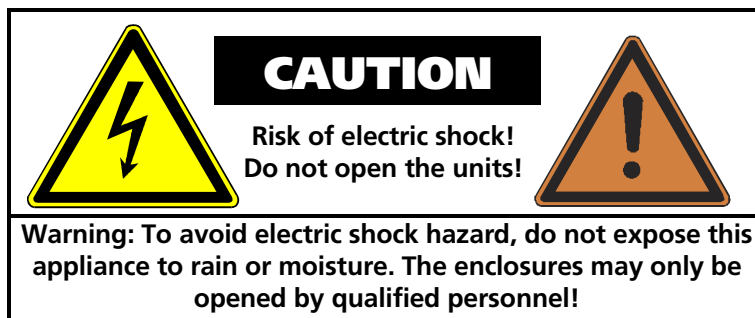

### Do not install devices in any of the following places:

- where the devices are permanently exposed to direct sunlight.
- near any heat sources and open fire. Do not put candles etc. on top of the speaker.
- where the airflow for cooling is blocked. A minimum distance of 10 cm to the heat sink on the rear of the speaker must be kept.
- where the devices are exposed to high moisture. Objects filled with liquids, such as a vase, must not be placed on the speaker.
- where the devices are exposed to strong vibrations and dust.



### Power supply

Before connecting the AC power cable of the SP speaker, please check if the available voltage is compatible with the operating voltage as indicated on the unit. If this is not the case, then the unit needs to be adapted by the manufacturer or an authorized service centre. If the unit is not compatible with the available voltage, it should never be connected! This could irreparably ruin the SP speaker.

Make sure that the power outlet supplies a ground connector, which must be connected to the unit via the PE conductor of the power cord!

All equipment, which is connected together using signal cables and has a connection to protective earth, must be connected to a common PE conductor. If not, there is a risk of an electric shock or the destruction of the connected equipment.

The power plug must always be used to disconnect from the power supply. Furthermore, the power plug must be easily accessible for use at all times.

### Protection of electrical cables

Power cords should be laid in such a way that they are protected against footstep damages, tensile strain and against being trapped.

### Transportation

When transporting the equipment, make sure that it is protected from vibrations.

### Cleaning

The equipment should only be cleaned with a damp cloth when it is not plugged in.

### Pauses in use

The power cord should be disconnected from the power source during longer pauses in use.

### Intrusion of objects or liquids

No objects or liquids should intrude or leak into the equipment.

## Maintenance and technical service

The user should not perform any maintenance work on the equipment other than that which is described in this manual. Repairs should be executed by a qualified service technician only.

In the following cases, the unit should be serviced by an authorized technician only if:

- the power cord or the mains connectors have been damaged.
- objects or liquids have gotten into it.
- it was exposed to rain.
- it doesn't appear to be functioning properly.
- it has fallen down or the enclosure is damaged.

## Mounting the speakers

If the weight of the speaker exceeds 25 kg then it is necessary for two people to carry it. To prevent injury, this equipment must be securely placed on the floor or secured to the wall according to the mounting instructions. Speakers, which are stacked, must be secured with securing straps. Please note that speakers can move as a result of vibrations. To prevent them from falling from their mounted position, they must be secured properly.

Speakers may only be suspended by qualified personnel.

Never use signal cables or power cords for suspending, aligning or securing the systems. When laying the connecting cables, make sure that nobody can trip.

The speakers must be hung by using at least two of the designated flying points. The same applies when lifting and aligning the speakers.

Never hang more than two speakers under one another without using the designated Kling & Freitag rigging equipment.

Ensure that all installation connections comply with the applicable safety guidelines and that the size and strength are sufficient. Further instructions are in our user's manual for assembly equipment and in the general safety instructions for speakers and assembly equipment.

For mobile and fixed installations, use only rigging equipment from KLING & FREITAG. Make sure to observe the included safety and mounting instructions for loudspeakers and accessories.

## Unwanted interference

RF interference on the power cord or on the line signal cables may lead to unwanted sound interference.

## Damage caused by the speakers' magnetic fields

Speakers are permanently surrounded by a magnetic field, even when they are not operating. Therefore, during transport and placement of the speakers, it is important to ensure that there is always approx. 1 m between the speakers and magnetic data media and computer/video monitors.

## The following signals may damage the speakers

- permanent high-pitched signals with high frequency and continuous noise from feedback.
- permanently distorted signals with high power.
- noises, which occur when the SP speaker is connected while equipment is being connected, disconnected or switched on.

## Preventing hearing damage

To prevent the risk of hearing damage, avoid being too close to operating speakers, even if the volume level seems to be low enough. In general, volume levels over 90 dB can cause hearing damage.

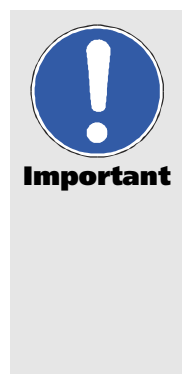
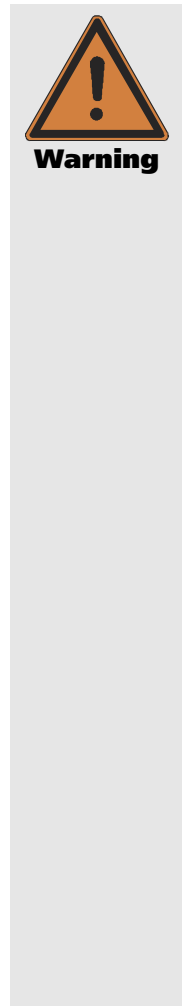

## 2. Introduction SP Loudspeakers

'SP' denotes the 'Self Powered' product line in the K&F range of loudspeakers. Based on selected K&F speaker systems, the 'SP' models are equipped with state-of-the-art integrated driver circuits and Class D power amplifier technology. The extremely lightweight system electronics replace ponderous racks, power amplifiers, controllers, and speaker cables.

Aside from the integrated power amplifier and input modules with controller functions, the full-range systems possess a passive crossover so that the advantageous features provided by the K&F passive technology (all-pass filter, protection circuits) remain usable. The frequency separation for the subwoofers is controlled by an active 110 Hz low-pass filter.

Integrated phase optimisation allows for all systems in the 'SP Series' to be combinable with one another. With this, the 'SP' speakers, when the filter section is switched off, have a completely comparable sound to the corresponding versions without integrated power amplifier technology. Operations using a K&F System Controller CD 44, CD 24 (discontinued) and C2 (discontinued) are also possible, which is appropriate for many applications.

Operating the 'SP Series' is incredibly easy: The full-range systems reproduce the complete frequency spectrum. If necessary, the 'SP' subwoofers in parallel operations can provide an additional bass boost.

### The Input Module

- Line signal input
- Limiter section (feed-forward RMS-limiter and peak limiter in feed-back design).
- High pass filter, 45 Hz tops, and 32 Hz subwoofers
- Low pass filter 110 Hz (only subwoofer systems)
- System specific, switchable frequency deemphasis ('FILTERS ON/ OFF') controllable by a covered switch on the connecting terminal
- Phase correction
- Level adjustment (countersunk level control on the connecting terminal)

### The Amplifier Module

- 1 x, or 2 x 1 kW Class D state-of-the-art power amplifier
- Minimal dimensions (speaker dimensions of the models without the 'SP' module are retained)
- Low weight (weight increase of 2.5 / 4 kg as compared to systems without the 'SP' module; and with the Line 212 – SP, the weight even stays identical)
- High efficiency enables convection cooling, because of which bothersome fans are unnecessary
- High fidelity (even in high frequency range) and a large power bandwidth resulting from impedance optimisation

## Modes of Operation

- Operations without external controller:  
with activated filters (FILTERS 'ON'), all K&F models in the 'SP Series' are combinable with one another by simply linking the signal from one speaker to the next.
- With optional K&F System Controller\*:  
via a K&F System Controller CD 44, CD 24 (discontinued) or C2 (discontinued, with system plug-in card) or an Audio DSP\*
- if used with BSS Soundweb, FDS 366, 336, 334, and XTA DP 226, 224, K&F system parameters are available upon request

\* The operation of the K&F 'SP' models with K&F System Controller or Audio DSP is recommended for uses in which special filter presets are advisable, i.e. in combination with passive systems of the 'CA Series', in cluster operations (top low cut), when bass and high boost are necessary, adjustment to the room acoustics (EQ), etc.

### The following K&F 'SP' speakers are available:

Full-range systems: CA 1001 - SP,  
CA 1201 - SP,  
CA1215-6 - SP, CA 1215-9 - SP  
CA 1515-6 - SP, CA 1515-9 - SP  
LINE 212-6 - SP, LINE 212-9 - SP

Subwoofers: SW 112 - SP, SWi 112 - SP,  
SW 115D - SP, SWi 115D - SP,  
SW 118E - SP, SWi 118E - SP,  
SW 215E - SP



### 3. Connectors, Controls and Displays

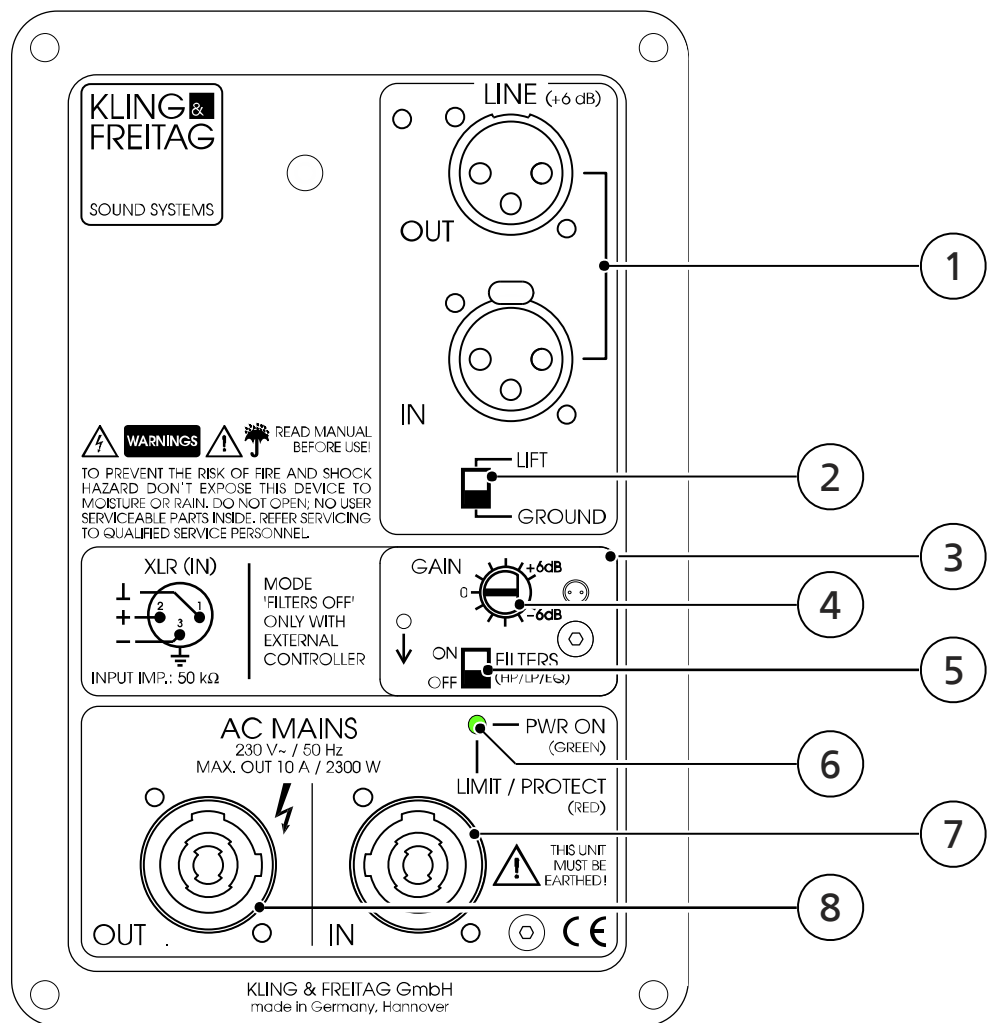

#### 1) LINE IN and LINE OUT (+6 dB)

Electronically balanced input and output connectors. Use the XLR female connector (marked 'IN') as input. The parallel-wired XLR male connector ('OUT') is for connection to further 'SP' loudspeakers.

#### 2) GROUND LIFT

When the 'Ground Lift' switch is set to LIFT, pin 1 of the LINE IN connector (ground) is not connected to the chassis ground of the integrated amplifier module. The ground connection between LINE IN (XLR male) and LINE OUT (XLR female) is maintained. The use of the 'Ground Lift' switch is sometimes necessary in dealing with hum problems (see chapter 10.1)

**Never tape over the protective earth on the plug – danger to life!**



#### 3) PROTECTIVE COVER

The protective cover prevents unwanted adjustment of the gain control and filter ON / OFF switch. The cover has a snap-in lock. In order to reach the controls beneath, turn the cover sharply down in the direction of the arrow.

#### 4) GAIN CONTROL ( $\pm 6$ dB)

- a) The gain control can be used to adjust the input level of the amplifier module by  $\pm 6$  dB. It serves to balance the volume levels of the various systems. In order to avoid overloading the input circuit or mixer's output circuit, it should normally be set in the case of K&F full-range systems at 0 dB (centre notch setting).
- b) When operating with K&F System Controller, set the input level of the amplifier module on the controller (Input Gain). The gain control on the SP speaker should be set at 0 dB (centre notch setting). One exception to this rule is a cluster arrangement, in which the inner speakers should be set at a lower level than the outer ones. In this case, the level of the gain control on the inner SP speakers can be adjusted downwards accordingly.

When operating with additional bass systems it is very important that the respective volume levels between the top speakers and the bass systems are correctly balanced. To this end, the sound engineer should check the volume levels during the set-up and adjust them accordingly. When setting up a system without a K&F System Controller this adjustment should be carried out using the gain control of the SP subwoofer; in the case of a system with K&F System Controller, set the gain on the controller.

Normally we recommend the following settings\*

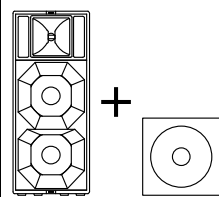
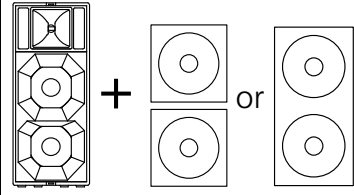
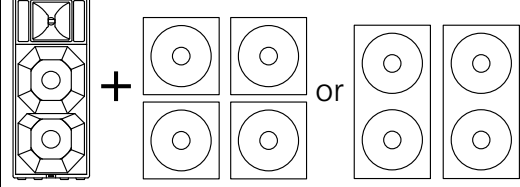
Configuration:	Gain control
	Line 212: <b>- 6 dB</b>  Subwoofer: <b>+6 dB</b>
	Line 212: <b>0 dB</b>  Subwoofer: <b>+6 dB</b>
	Line 212: <b>0 dB</b>  Subwoofer: <b>0 dB</b>

- \* These details may vary due to different room geometries. The position of a bass speaker is also crucial for its actual sound level. A bass speaker, which is on the floor, can be a few decibels louder than a flown bass system because of the floor reflections. Because of this, a sound engineer must always fine-tune the system using the corresponding level controls.

### 5) FILTERS ON / OFF (High Pass / Low Pass / Equalizer)

This switch turns the filter in the SP module on ('ON'), or off ('OFF').

- a) The switch should always be in the 'ON' position when the speakers are being driven without K&F System Controller.
- b) The switch should always be in the 'OFF' position when the speakers are being driven with K&F System Controller.

The filters consist of:

- high-pass: protects the speakers against mechanical stress due to frequencies outside the speaker's frequency range (protection against subsonic frequencies)
- EQ: filter for basic equalization, optimising the frequency response of the speaker systems.

Furthermore, the SP filter module has a phase alignment, which prevents loss of certain frequencies due to phase shift between mid-high and bass systems. Thus the combination of all available K&F mid-high SP systems with all K&F bass SP systems is possible, and 100% phase compatibility with all K&F speakers operating in conjunction with a K&F System Controller in the '2-way active' mode is guaranteed.

### 6) LED POWER ON (GREEN) and LIMIT / PROTECT (RED)

The LED is dual-purpose:

- a) When the LED is green, the speaker is connected to the supply voltage and ready for operation
- b) The LED will turn red if...

...the input signal is so high that the internal limiters reduce its level.

The limiters consist of a peak limiter, which limits the peaks of the signal, and an RMS / thermal limiter, which continuously regulates excessive levels. During normal operation, the red light may occasionally illuminate briefly when the barely audible limiter cuts in to limit peak levels. It does indicate that the level peaks are limited by the limiter circuit. The peak performance of the speaker has then been reached.

Should the red light come on more frequently or remain illuminated, the output level of the mixer should be reduced. When speakers with and without SP module are in operation simultaneously, the gain control on the SP speaker can be turned down, provided the level is sufficient for the other power amplifiers. The limiter protects the speaker from damage due to excessive levels.

- c) The LED stays permanently red, if...
- ...the protection circuitry of the integrated power amplifier cuts in and as a result, no further signal reaches the speaker (Protect Mode).
- The protection circuitry switches off the integrated power amplifier,...
- ...if the temperature of the amplifier module is too high. As soon as the temperature falls below the critical value, the amplifier module is switched on again automatically. Excessive temperatures can be caused for example by inadequate ventilation of the heat sink. Make sure that the heat sinks are not covered or positioned directly against a wall.
  - ...if the output impedance is too low or in the case of a short circuit, caused for example by a defective chassis or a faulty component on the crossover.
  - ...if the amplifier has an internal fault. The SP amplifier module checks that all is functioning correctly during operation. As soon as a fault becomes apparent, the module switches into protect mode. If only one module has a fault, the input signal is attenuated by 70 dB, to prevent damage to the other module.

**Measures to be taken when LED is red:**

Fault	Measure	Function
LED remains red or flickers continually during operation.	Reduce output level on mixer until the LED goes out or flickers only occasionally	Limiter
No or too low output signal, LED shows red in spite of reduced mixer output level.	Allow to cool. The amplifier module switches itself on after a few minutes. Provide sufficient ventilation.	Temperature protection
No or too low output signal, LED stays red after cooling down.	Have loudspeaker checked by authorized service technician.	Other protection
Output signal is too low, no bass frequencies or no high frequencies.	Have loudspeaker checked by authorized service technician.	Other protection

**7) AC MAINS 'IN'**

Connect this PowerCon socket using the mains cable supplied to a max. 16 A fused mains socket, paying particular attention to the stated mains voltage! Connection to an incorrect mains voltage can result in irreparable damage!

**8) AC MAINS 'OUT'**

Socket for connection to further equipment such as further speakers with SP module. **Use only connection cables, which conform to your national safety regulations.**

Maximum power consumption:      230 V: 10 A / 2300 W  
     110 V: 10 A / 1150 W



## 4. Power Cord

In Germany, a pre-constructed ready for use power cord is included in the delivery. For deliveries to foreign countries, a pre-constructed power cord incl. PowerCon plug is included. Because of the different standards abroad, the power plug is not included. This must be subsequently assembled only by qualified electrical specialists.



brown = BN = L

green / yellow = GNYE =  $\perp$

blue = BU = N

## 5. Rigging Instructions for Line 212 Systems

The speakers may only be mounted by trained specialised personnel with proof of their qualifications as an experienced 'rigger'.

Please follow the accompanying instructions for speakers and assembly equipment.

Ensure that all connections are secured to prevent their detaching on their own and that only admissible statically tested and sufficiently sized connecting devices, ropes and chains are used.

Pay attention to the required safety factors. Please follow the accompanying safety and mounting instructions carefully.

A maximum load of 73 kg may be suspended from the two flying points of one Line 212 system. **This means a maximum additional load of 36.5 kg on each 'allsafe JUNGFALK' flying point.** This applies for both vertical (see details on this page) and horizontal suspension (see details on next page).

### 5.1 Vertical Suspension



The Line 212 System must always be mounted with two wire ropes or chains, which are independent of one another! Furthermore, the systems, no matter if individual or connected to one another, must be secured onto the 'allsafe JUNGFALK' flying track on the rear. This safety rope may be used for aligning the systems.

**The safety rope must have a minimum length of 100 cm and must be attached so that, in case it falls, the height of the fall is kept to a minimum. A possible fall height of 20 cm may not be exceeded! With a higher fall height, the dynamic load of a fall could be inadmissibly high; potential risk of system crash.**

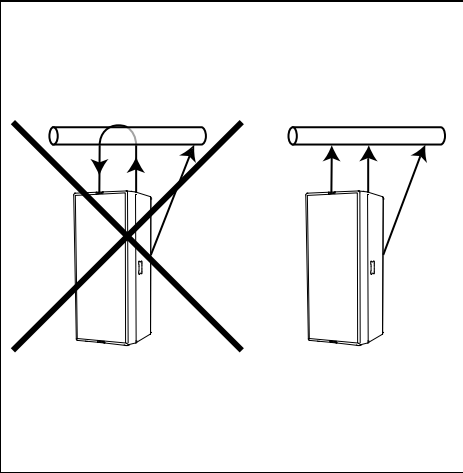

The safety ropes of different systems must always come together at one point.

Each of the utilised separate lifting accessories (chains / wires / shackles) must be able to carry the 12-fold load of the total weight.

While installing, be sure that the system can swing in case a rigging point fails. With this in mind, the speaker must be mounted so that no people or objects are within the potential range of the swinging speakers.

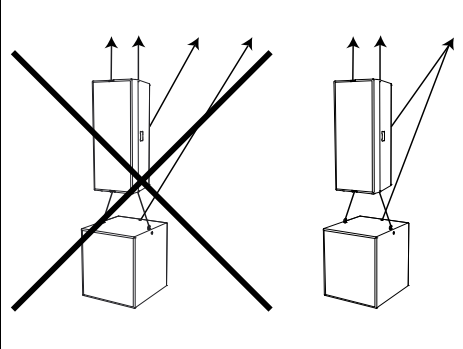

The weight of the speaker hung below may not exceed 73 kg (this weight corresponds to the approx. weight of a SW 215E-SP).

The angle of the rope / chain to the top of the speaker mounted below may not exceed 45°.

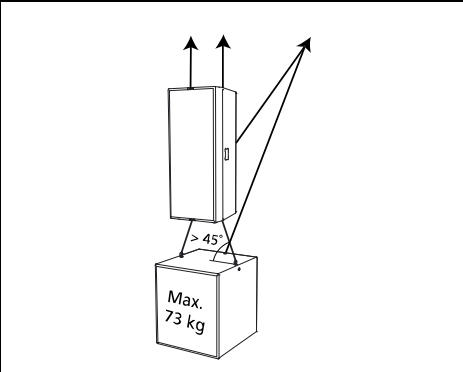



**Warning**

## 5.2 Horizontal Suspension

If a speaker unit consisting of several connected systems is to be flown and aligned, then the individual speakers must be attached to one another before connecting them to the 'allsafe JUNGFALK' Flying Track. Consult the provided illustration when doing so. For the rear connection of the loudspeaker systems, use the double stud fittings available from Kling & Freitag and a proven 1/2" shackle (alternative single stud fittings and 3/8" shackle). Pull the threaded bolt of the shackle with a torque of 10 Nm (**hand-tight with 200 mm long lever, e.g. screwdriver**). **Alternatively, you can use proven, high-strength shackles with a cotter pin.** Only in this way can you ensure that the bolt will not become loose.



The 'allsafe JUNGFALK' flying track can only support weights up to 73 kg. Therefore, the load must be distributed on several flying tracks when suspending the systems.

For horizontal operations, the system is designed for a maximum array of three Line 212-6 systems. More of these systems may not be flown below one another.

*We recommend using the BGV C1 certified and type tested Click & Fly Rigging System for mounting the Line 212 systems (see the 'Click & Fly for Line 212 / SW215E' user's manual).*

**Please follow the following instructions for flown operations without the Click & Fly Rigging System:**

<p><b>Wrong:</b></p> <ul style="list-style-type: none"> <li>– The upper rigging points of the top speaker must carry the full load. Consequently, the permissible max. load of the top points is exceeded.</li> <li>– The speakers are not secured by the additional safeties.</li> </ul>	
<p><b>Right:</b></p> <ul style="list-style-type: none"> <li>– The load of the individual speakers is threaded through the bent continuous bracket. The load is, therefore, held by the bracket and the speakers' flying points consequently only have to carry the load of the corresponding speaker.</li> <li>– The speakers are connected to one another on the rear. The suspension point is located on the connection of the two lower speakers. As a result, the load is distributed to both speakers.</li> </ul>	

## 6. Using the 'allsafe JUNGFALK' Flying Points



Take the single stud fitting in one hand...



... and push the locking device up against the spring tension.

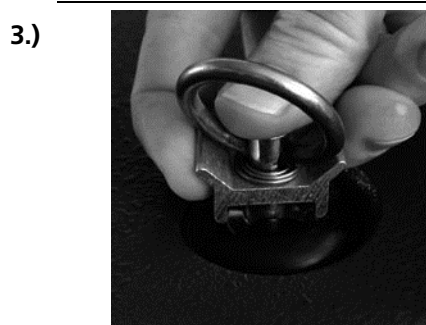

Put the flat head of the holding bolt into the guiding of the flying point.

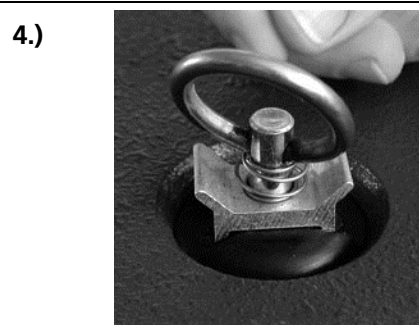

Release the locking device when the single stud fitting is located in the middle of the flying point. Make sure that the locking device clicks into place.

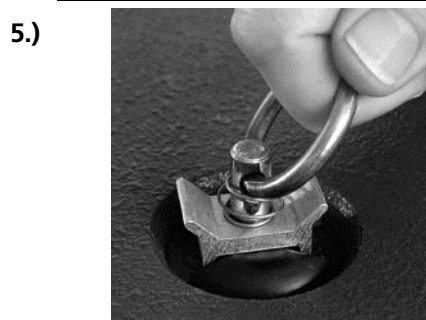

Check that the single stud fitting is securely fastened and cannot be pulled out.





## 7. Using the Rear Mounted 'allsafe JUNGFALK' Flying Track

The 'allsafe JUNGFALK' flying track can be used for fixing and adjusting the speaker systems.

**The 'allsafe JUNGFALK' flying track can only support weights up to 73 kg!**

**Please also consult the provided instructions for speakers and assembly equipment.**



### 7.1 Mounting the Single Stud Fittings

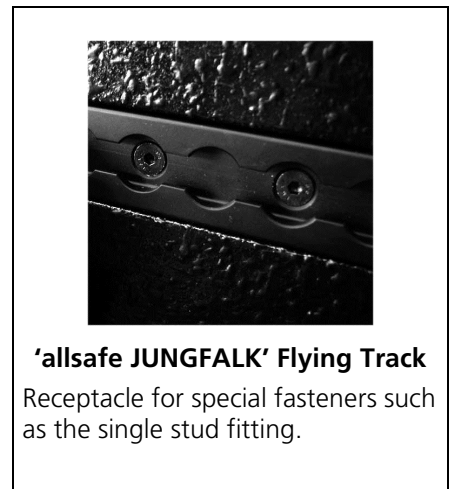

Take the single stud fitting in one hand...



... and push the locking device up against the spring tension.

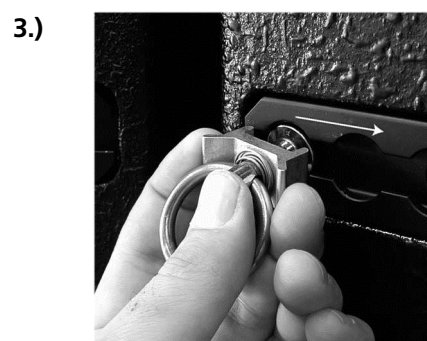
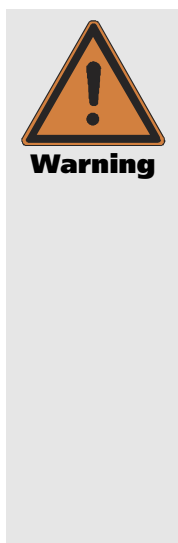

Slide the flat head of the holding bolt into the guiding device of the flying track and slide the single stud fitting sideways into the flying track.



Release the locking device when the single stud fitting is located over the tabs of the track. Make sure that the locking device clicks into place. Make sure that it is secured tightly.

**7.2 Mounting the Double Stud Fitting**

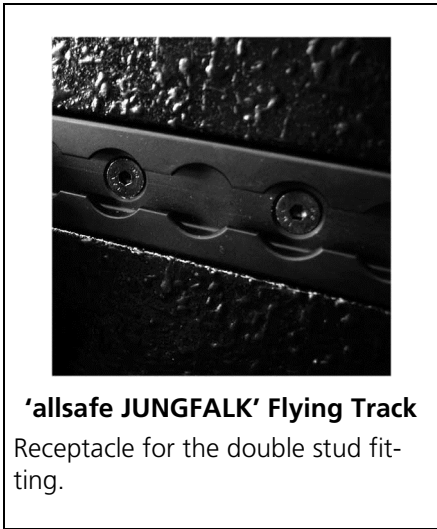
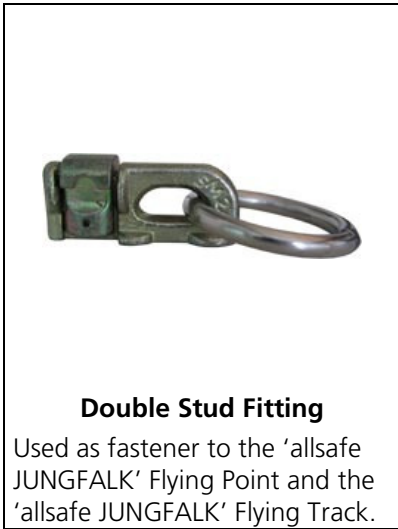

Align the double stud fitting as shown above and push it into the track,...

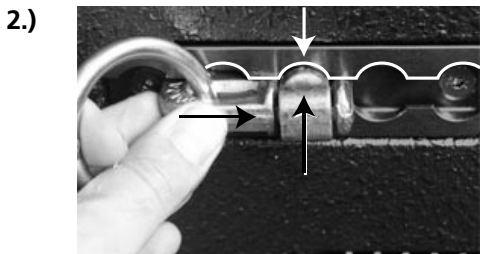

... slide the pushed double stud fitting to the middle of the speaker until it clicks into place. Make sure that it is secured tightly.

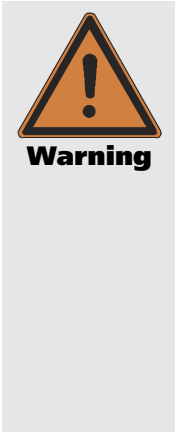

## 8. Coverage Pattern of the Line 212 – SP Systems

The Line 212 can be operated in a vertical or horizontal position. The coverage pattern of the speaker can be adapted to special needs by a 90° rotatable horn.

The following graphics demonstrate how to recognize how the built-in horn emits in a standing speaker: To determine the coverage pattern of the high frequency horn, shine a flashlight through the front covering at the level of the horn. You will find a silver stripe that determines the position and coverage angles of the horn.

**DEFINITION:**

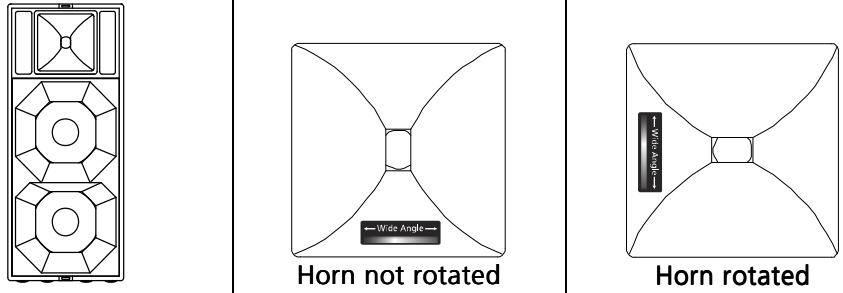

Standing speaker:

Model	Horn not rotated	Horn rotated
LINE 212-6 - SP	65° h x 50° v	50° h x 65° v
LINE 212-9 - SP	90° h x 50° v	50° h x 90° v

### 8.1 Changing the Coverage Pattern

The front grille of the Line 212 - SP is divided into two sections (except the version 'Outdoor Installation'). Changing the coverage angle is possible by only removing the upper section of the grille. To turn the horn, follow these steps:



- 1) Disconnect the power plug!
- 2) Make sure that no objects fall into the enclosure!
- 3) Remove the four grille mounting screws from the top on the sides of the speakers with a 3 mm Allen key and remove the grille from the speaker enclosure. It may be necessary to use a screwdriver in the middle of the top grille edge to pry up the grille. There is a groove in the grille in this position (under the locking profile) just for this purpose.
- 4) Remove the six screws from the high frequency horn (also using a 3 mm allen key). Loosen the high frequency horn by using both hands, palms to the outside, to grasp into the horn and lift the horn with even pressure from the palms of your hands towards the outside. Never use a screwdriver or similar objects to reach behind the edge of the horn, as this could damage it.
- 5) Rotate the horn 90° and screw the horn on tightly again (do not force it!).
- 6) Screw the grille on tightly.



If the coverage angle needs to be changed often, make sure that the horn is not always rotated in the same direction, as the connecting cable may cause the contacts of the driver to become loose. **Open wires may hit other live parts: Danger of electrical shock.**

## 9. Mounting Instructions for Speakers

Mount the speakers securely. To avoid injury or damage, always be sure to mount the speakers securely so that they do not fall. Speakers, which are stacked, must be secured with securing straps. When laying the connecting cables, make sure that nobody can trip.

The stability of stacked systems (also valid for the use of stands and distance rods!) is contingent upon the following stability requirement. These conditions must, therefore, be guaranteed by the user:

**Stacked systems may not fall over even if they are inclined by 10° in each direction. If this requirement is not fulfilled, then it is necessary to take steps to achieve compliance. Possible measures include strapping it to an appropriate base structure or fastening it using safety straps.**

We recommend using the optionally available transport covers with castors when transporting and positioning the system. These covers have handles, which considerably simplify the carrying and stacking of the Line 212 systems. We therefore recommend removing the covers after the systems have been positioned. Always loosen the lower catch first so that the cover does not fall over.

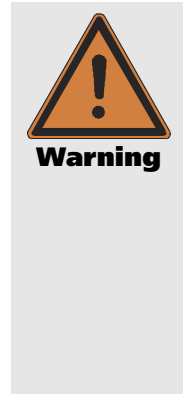

### 9.1 Proper Arrangement of the Loudspeakers

Be aware of the fact that the logical targeted alignment of this high quality speaker system can lead to a significant qualitative increase in the acoustic result. It is not possible to make generalities about the alignment of specific systems because the room has a substantial influence on the signal and the audible result.

As a rule, the mid- and high-transducers of loudspeakers should be mounted above the audience's face value, so that the sound distribution cannot be shadowed.

In many cases, it is advisable to mount a loudspeaker higher, so that the sound will be distributed throughout the room more evenly. Low standing systems result in a greater difference in volume between front and back seats than higher standing systems.

Please note that this is only a general guideline and the best possible result may vary from room to room.

To simulate the correct alignment of the speakers beforehand, there are various programs such as 'Ease' or 'Ulysses'. The Kling & Freitag speaker system data is available for download on our website [www.kling-freitag.de](http://www.kling-freitag.de).

The following graphics will assist in making a rough estimate as to the distance range of speaker systems. The graphics only take into consideration the sum of the direct sound and not the influence of the room. Because of this there can, in some cases, be noticeable deviation.

#### Distance range of SPL (direct sound level):



## 9.2 Arrayed Speaker Systems (Cluster)

If the loudspeakers are operated through an optional K&F System Controller, we recommend turning on the 'Top Low Cut' filter for clustered operation. Thus the frequency response for this application can be optimised (see user's manual of the controller).

If the Line 212 Systems are operated in a cluster without a K&F System Controller (speakers are set up directly next to one another), then lower the 'EQ LOW CUT' frequency as described below!

	EQ LOW CUT
Frequency	120Hz
Quality (Q)	0.55
Bandwidth (oct.)	2.35
Level	-2.95dB

1. If several Line 212-6 with a horn coverage pattern of 65°h x 50°v are arranged on one side (cluster / array), it is recommended for the Line 212-6 to have a horizontal array angle of 38.5° to one another (see fig. 2).
2. In a cluster comprised of a combination of the Line 212-6 with Line 212-9, we recommend an array angle of 45° (see fig. 3).
3. With a rotated horn (Line 212-6 standing: 50°h x 65°v / Line 212-9 standing: 50°h x 90°v), an array angle of 30° is recommended for both versions (see fig. 1).

Because increased interference effects occur when several 90° systems are arranged next to one another, the clustering of several Line 212- 9 is only conditionally recommendable.

Fig. 1

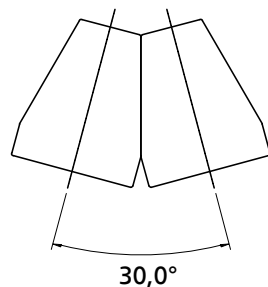

**Line 212- 6**  
(horn rotated)  
horn 50° h x 65° v

**Line 212-9**  
(horn rotated)  
horn 50° h x 65° v

Fig. 2

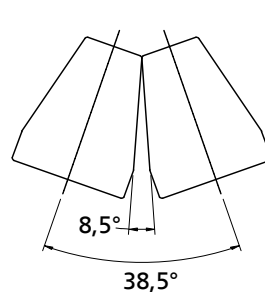

**Line 212-6**  
(horn not rotated)  
horn 65° h x 50° v

Fig. 3

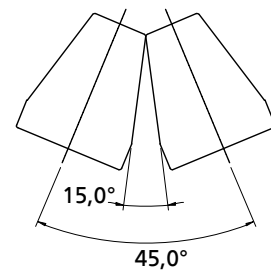

Combination  
(horns not rotated):

**Line 212-6**  
Horn 65°h x 50°v

with

**Line 212-9**  
horn 90°h x 50°v

### 9.3 LINE 212 Systems on Top of SW 215E

In addition to the stacking foot grooves for stacks of identical enclosures, the subwoofer SW 215E also has stacking foot grooves for the Line 212 System.

One Line 212 System can be quickly and safely positioned on top of a vertically placed SW 215E.

Two Line 212 Systems can be precisely arrayed on top of a horizontally placed SW 215E.

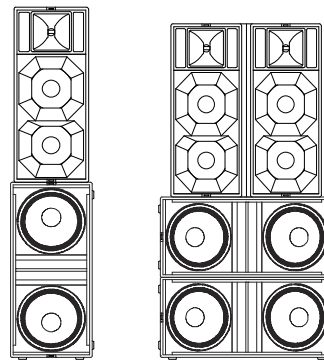

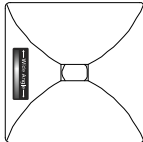
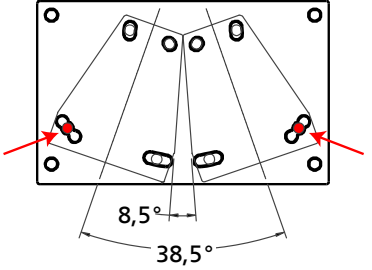
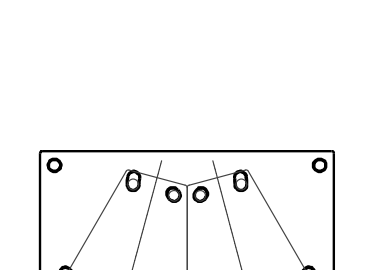
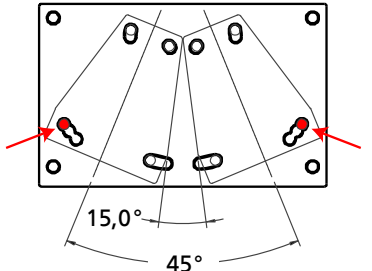
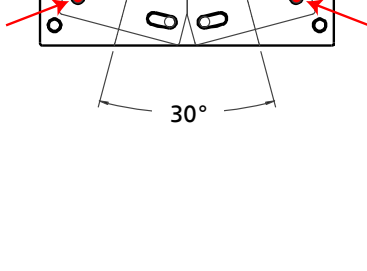
	 Horn <u>not</u> rotated on standing Line 212 system	 Horn rotated standing Line 212 system
Line 212-6 with Line 212-6		
Line 212-6 with Line 212-9		

Other combinations of Line 212 Systems are not recommended as they can cause unwanted interferences.

## 10. Wiring

Before connecting your SP system, be sure to switch off all connected appliances and turn down all level controls.

- We recommend the use of high-quality cables provided by KLING & FREITAG.
- For connections to the line signal inputs, please use 2-pin shielded microphone cable with high-quality connectors.
- Avoid ground loops (see chapter 10.1 )
- Make sure that the pin assignment of the line level connectors is correct. (2 + / 3 - / 1 ⊥).

### 10.1 Avoiding Ground Loops

#### 10.1.1 What is a Ground Loop?

Every component of a P.A. or Hi-Fi System has its own internal 0V reference (ground). This point is often connected to the protective earth connector (PE / Ground). If two or more units are connected to one another with a line level audio cable, there may be a ground connection through the ground of the power supply cable (yellow-green) as well as through the shielding of the audio cable. The voltage difference between these two ground points causes audible interference to come from the speaker.

#### 10.1.2 Avoiding Ground Loops

If there is a loud humming or buzzing after the 'SP' System has been connected, then set the 'Ground Lift' switches on the rear of the 'SP' speakers to the 'Lift' position (chapter: 3 / section 2)

If the noise is still audible, check if

1. the noise is caused by a ground loop before the speakers (e.g. mixing console, effects or equalizers).
2. the system or parts of the system are connected to an 'unclean' power supply - meaning one which is also running large motors or lighting systems. An 'unclean' supply voltage, electrostatic and electromagnetic fields can cause interference

#### Please observe the following basic rules:

- **Never !!! try to avoid a ground loop by disconnecting or taping the ground contact at the connector! Extremely dangerous!**
- If possible, only use high-quality audio appliances with balanced signal outputs and power cables with PE connectors.
- Use high-quality cables with good shielding.
- The point of ground for all connected components should merge at one central point. The power connections should lead out in a radial manner from one point and not be linked from one unit to the next.
- When installing appliances that create strong electrostatic or electromagnetic fields (large transformers, switch-mode power supplies), maintain some distance from other audio appliances. In extreme cases, the only solution is to create a completely independent 'audio ground'; in other cases, it is sufficient to connect a filter in front of the audio equipment.



## 10.2 Connecting the Power Connectors to the Connecting Terminal

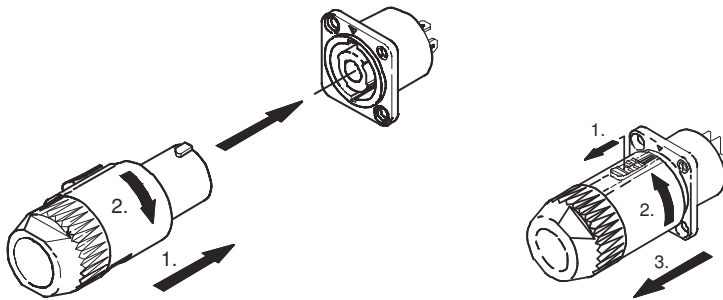

Only use the supplied power cable and connect it to a mains outlet with a 16 A fuse. See instructions in chapter 4, 'Power Cord' on page 13.





## 11. Configurations and Connecting Diagrams

### 11.1 Operating the Systems without K&F System Controller

The full-range system can be used alone or in conjunction with an SP subwoofer. The subwoofer has an integrated filter for use in this mode, which limits the bandwidth.

The full-range system is protected against low frequency (subsonic) signals by a high-pass filter and when used with bass speakers it is phase aligned with the subwoofers by means of alignment filters.

#### 11.1.1 Full-Range Mode

This mode of operation is ideal for speech and music applications without the need for a high bass content. Should more bass be needed, the bass level can be increased between 50 and 80 Hz at the mixing console.

The switch 'FILTERS' on the SP speaker must be at 'ON' in this mode.

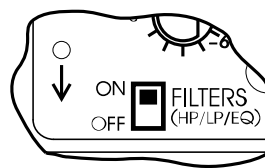

If you need a high-boost for covering larger distances (compensation of high frequency attenuation), then increase the 'EQ HIGH BOOST' frequency as described below!

If the mid-high systems are operated in a cluster (speakers are set up directly next to one another), then lower the 'EQ LOW CUT' frequency as described below!

	EQ HIGH BOOST	EQ LOW CUT
Frequency	14000Hz	120Hz
Quality (Q)	2.6	0.55
Bandwidth (oct.)	0.55	2.35
Level	+4.4dB	-2.95dB

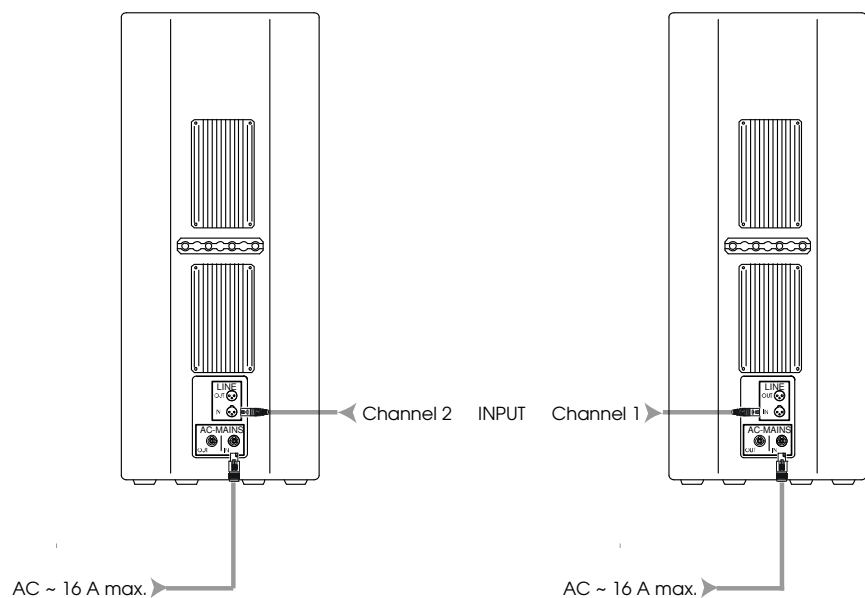

**11.1.2 Full Range Mode with Subwoofer**

You can link the input signal (for example from the mixer) from one loudspeaker to another. It makes no difference whether the input signal reaches the bass speaker first and is then transmitted to the mid-high speaker or the other way around.

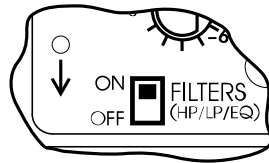

The switch 'FILTERS' on the SP speaker must be at 'ON' in this mode.

If you need a high-boost for covering larger distances (compensation of high frequency attenuation), then increase the 'EQ HIGH BOOST' frequency as in the following table!

If the mid-high systems are operated in a cluster (speakers are set up directly next to one another), then lower the 'EQ LOW CUT' frequency as described below!

	EQ HIGH BOOST	EQ LOW CUT
Frequency	14000Hz	120Hz
Quality (Q)	2.6	0.55
Bandwidth (oct.)	0.55	2.35
Level	+4.4dB	-2.95dB

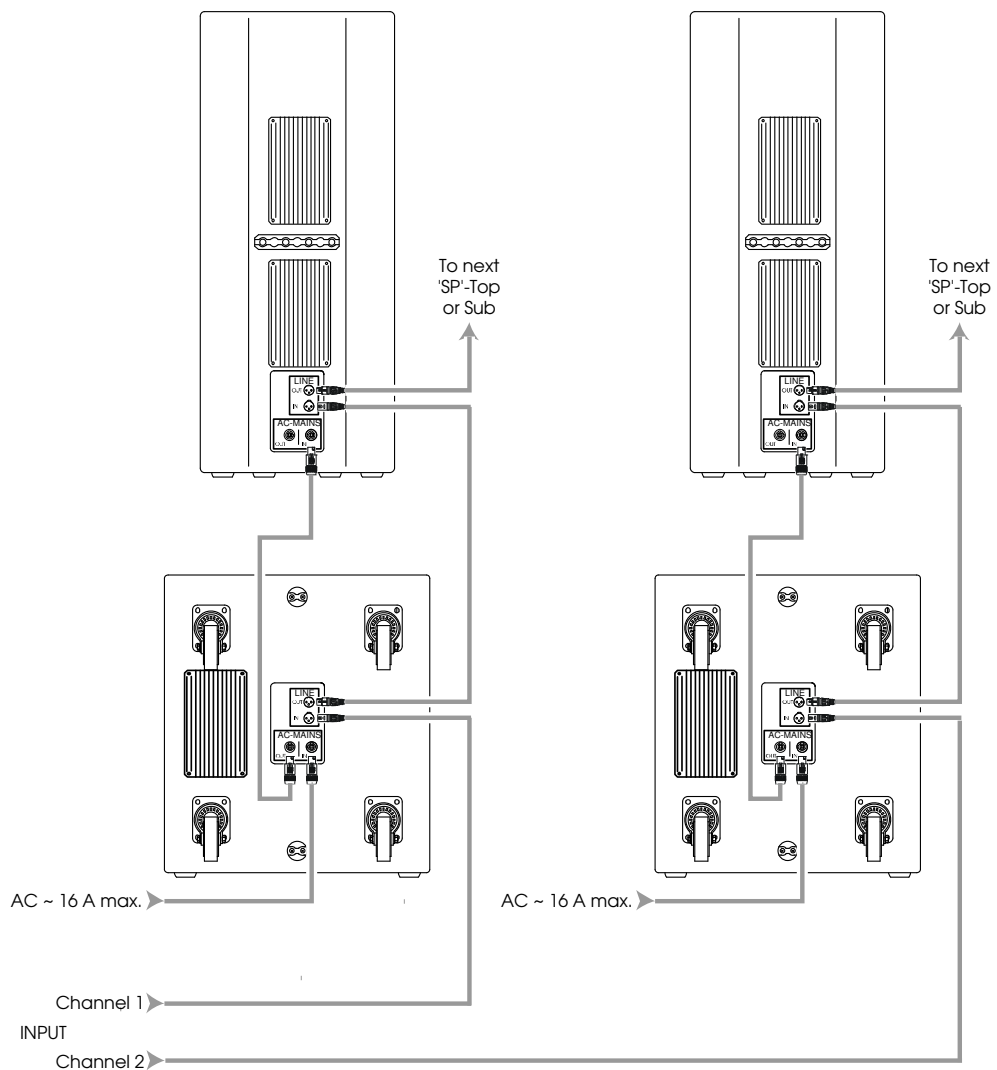

## 11.2 Operating the Systems with K&F System Controller

For optimal performance with an extended functional range we recommend using a K&F system controller. Instructions for use, connecting diagrams and detailed descriptions of the latest controller models 'CD 24' and 'CD 44' you can find in the corresponding user's manuals.

## 11.3 Maximum Configuration

It is possible to use a large number of SP speakers in parallel simultaneously, however, this number is limited according to the permitted minimum load impedance of the signal source (e.g. mixer, equalizer, etc.).

The total input impedance of all SP speakers must be larger than the permitted minimum load impedance of the signal source. If no manufacturer's recommendations can be found, take the output impedance of the signal source. In this case, we recommend a total input impedance at least 10 times higher than the stated output impedance of the signal source.

(The output impedance of your signal source can normally be found under 'Technical Specifications' in the manufacturer's instruction manual).



Definition:

$R_{OUT}$  = output impedance of signal source

$R_{IN}$  = input impedance SP - speaker =  $50k\Omega = 50.000\Omega$

$n_{MAX}$  = maximum recommended number of SP speakers

The maximum number of SP speakers can be calculated with this formula:

$$n_{MAX.} < \frac{R_{IN}}{R_{OUT} \times 10} = \frac{50k\Omega}{R_{OUT} \times 10}$$

Example:

$R_{OUT} = 75\Omega$

$$n_{MAX.} < \frac{R_{IN}}{R_{OUT} \times 10} = \frac{50.000\Omega}{75\Omega \times 10}$$

$\Rightarrow n_{MAX.} < \underline{\underline{66}}$

## 12. Operating the Speakers

- Switch off all equipment and make sure that the SP speakers are not connected to a power source.
- Connect your SP systems in accordance with the preceding connection diagrams. **Use only mains cables, which comply with your national safety regulations.**
- Upon completing the wiring, ensure that the connected speakers are working in phase. To do so, use i.e. a phase checker. A phase error can also be recognized when the connected channels are used simultaneously. During simultaneous use the bass frequencies become notably quieter or the mid-frequencies such as voices cannot be located.
- Switch on first the peripheral units (mixer, effects, etc.), then, if used, the K&F System Controller and connect lastly the SP loudspeakers. Always use the before mentioned switching order. Otherwise switching noises may damage the system.
- If there is interference, turn off all appliances in the reverse order and check all cable connections. Next, turn up all other peripheral units, and check these for interference.
- Your system should now be ready for operation.
- You can now turn up the level on the mixer.
- If you are using additional bass systems, you can now balance the respective volume levels of the top speakers and bass systems. A fine adjustment of the system without K&F System Controller can be obtained using the gain control on the SP loudspeakers (not on the mixing console!).
- When switching off the system first disconnect the 'SP' loudspeakers. Then you can switch off the remaining units.



**Warning**



**Important**

## 13. Touching Up Damage to Paint / Changing the Front Foam

Although the PU structured paint used by KLING & FREITAG is extremely resistant, we recommend using protective covers or cases to help avoid damaging the paint during i.e. continuous mobile use. If paint damage occurs despite these precautions, it can be touched up by using commercial acrylic paint in the appropriate RAL colour of the speaker. To replace the filter foam, send the front grille incl. foam to KLING & FREITAG GmbH. Upon payment for expenses, the grille with the new covering will be returned.

**14. Block Diagram LINE 212 - SP**

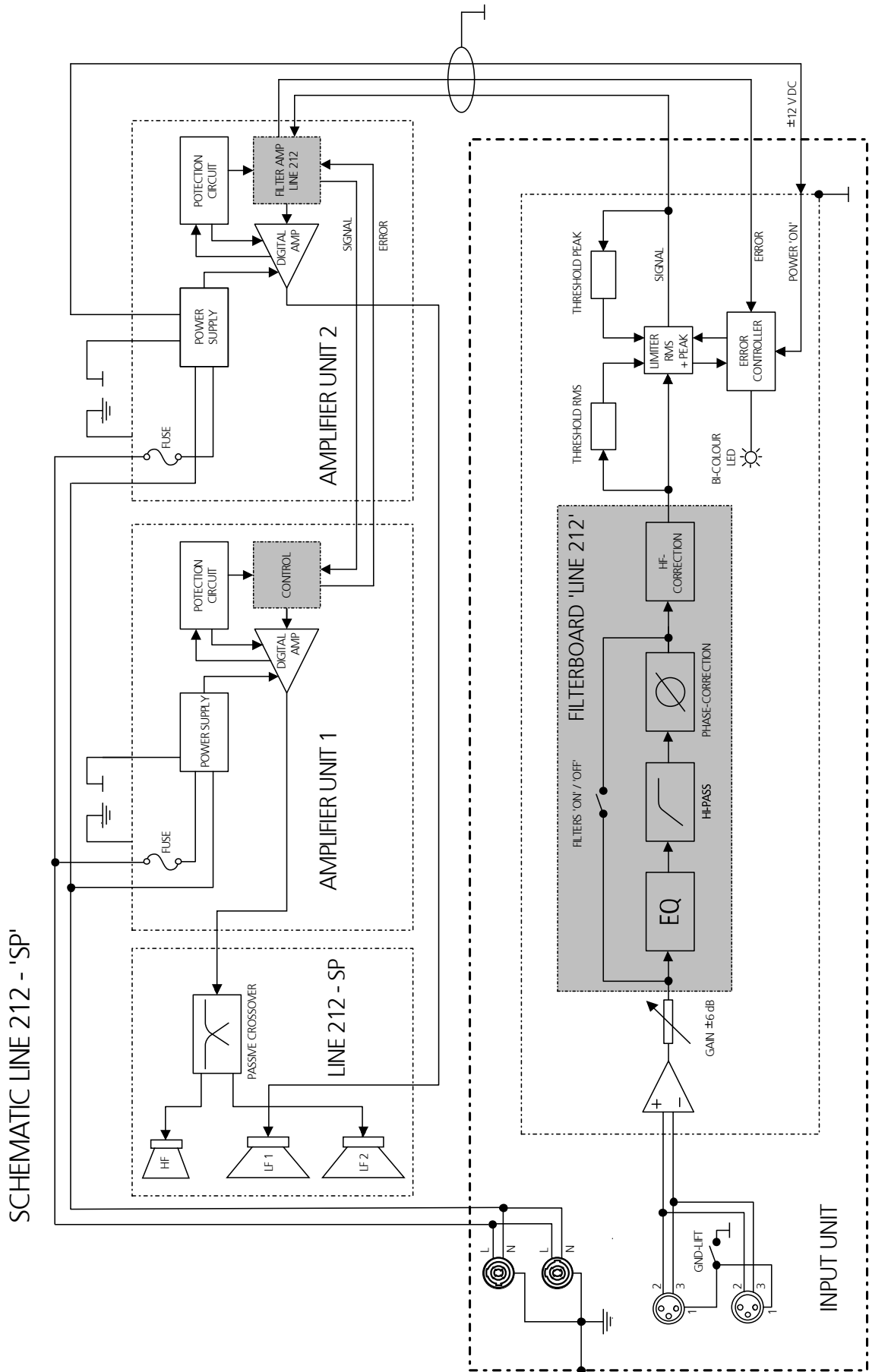

## 15. Technical Specifications

### 15.1 LINE 212-6 - SP

Loudspeaker	
Design	2+1-way full-range system with integrated driver and power amplifier technology, completely horn loaded, bass reflex tuning
Frequency range -10 dB	51 Hz - 20 kHz ('FILTERS ON'), 65 Hz - 20 kHz ('FILTERS OFF') 49 Hz - 20 kHz ('FILTERS OFF' with K&F System Controller)
Frequency range $\pm$ 3 dB	66 Hz - 18 kHz ('FILTERS ON'), 130 Hz - 18 kHz ('FILTERS OFF') 60 Hz - 18 kHz ('FILTERS OFF' with K&F System Controller)
Nominal coverage angle	65° x 50° / rotatable horn
Directivity index (DI)	12 (+1.5/-3) 600 Hz - 16 kHz
Max. SPL	135 dB (SPL peak/1 m)
Components	1 x 12" woofer and 1 x 12" low-mid chassis with horns, 1.5" high freq. driver with 75 mm titanium dome on rotatable CD horn
Crossover	Active (1) and passive (2) in FLC technology, delay time correction and phase optimisation, self-resetting protection circuit for 1.5" driver
Supply voltage	AC 195-250 V, 50 / 60 Hz (230 V version)
alternative	AC 95-125 V, 50 / 60 Hz (115 V version)
Power consumption (nominal)	@ 230 V: 1.25 A      @ 115 V: 2.5 A
Max. Power consump. (Irms / <500 ms)	@ 230 V: 8 A      @ 115 V: 16 A
Idle current	@ 230 V: 360mA      @ 115 V: 720 mA
Power connectors	Neutrik PowerCon, lockable, 1 input and 1 output
Input module	
Signal connectors	Pin 1 = ground / pin 2 = + signal / pin 3 = - signal LINE IN: XLR 3 pin female LINE OUT: XLR 3 pin male, parallel with LINE IN
Input sensitivity	+6 dB / 1.55 Vrms for rated output
Input impedance	50 kW (balanced / unbalanced)
Common mode rejection	Min.: 74 dB, typical: 90 dB
Controls	Level control $\pm$ 6 dB, bypass switch for the active filters (for operations with K&F System Controller), ground lift switch
Display	Bi-coloured LED: green = Power On, red = Limit / Protect
Driver circuit	Peak limiter, RMS limiter High-pass 45 Hz (-3 dB), 24 dB / octave ('FILTERS ON'), Phase correction, frequency equalisation (EQ)
Amplifier module (2 x)	
Type	Class D
Power	1000 W @ 8 $\Omega$ ( EIAJ / 1 kHz, 1% THD)
Power bandwidth	10 Hz to 30 kHz
Damping factor	> 500 (100 Hz), > 100 (10 kHz)
S / N ratio	> 105 dB (A)
Cooling	Air convection (without fan)
Protection circuits	Short circuit, over-temperature, clipping, overload
Enclosure	
	Trapezoidal, frame-reinforced 15 mm birch plywood with highly resistable grey or black structured paint, 2 butterfly handles, ball proof front grille with exchangeable black acoustic foam
Rigging	4 flying points 'allsafe JUNGFALK' 1 rear mounted flying track 'allsafe JUNGFALK'
Dimensions	429 x 1025 x 510 mm (W x H x D)
Weight	57.5 kg
Options	special finish in RAL colours



## 15.2 LINE 212-9 - SP

<b>Loudspeaker</b>	
Design	2+1-way full-range system with integrated driver and power amplifier technology, completely horn loaded, bass reflex tuning
Frequency range -10 dB	51 Hz - 20 kHz ('FILTERS ON'), 65 Hz - 20 kHz ('FILTERS OFF') 49 Hz - 20 kHz ('FILTERS OFF' with K&F System Controller)
Frequency range $\pm$ 3 dB	66 Hz - 18 kHz ('FILTERS ON'), 130 Hz - 18 kHz ('FILTERS OFF') 60 Hz - 18 kHz ('FILTERS OFF' with K&F System Controller)
Nominal coverage angle	90° x 50° / rotatable horn
Directivity index (DI)	10 ( $\pm$ 1.5) 600 Hz - 12 kHz
Max. SPL	135 dB (SPL peak/1 m)
Components	1 x 12" woofer and 1 x 12" low-mid chassis with horns, 1.5" high freq. driver with 75 mm titanium dome on rotatable CD horn
Crossover	Active (1) and passive (2) in FLC technology, delay time correction and phase optimisation, self-resetting protection circuit for 1.5" driver
Supply voltage	AC 195-250 V, 50 / 60 Hz (230 V version)
alternative	AC 95-125 V, 50 / 60 Hz (115 V version)
Power consumption (nominal)	@ 230 V: 1.25 A      @ 115 V: 2.5 A
Max. Power consump. (Irms / <500 ms)	@ 230 V: 8 A      @ 115 V: 16 A
Idle current	@ 230 V: 360mA      @ 115 V: 720 mA
Power connectors	Neutrik PowerCon, lockable, 1 input and 1 output
<b>Input module</b>	
Signal connectors	Pin 1 = ground / pin 2 = + signal / pin 3 = - signal LINE IN: XLR 3 pin female LINE OUT: XLR 3 pin male, parallel with LINE IN
Input sensitivity	+6 dB / 1.55 Vrms for rated output
Input impedance	50 kW (balanced / unbalanced)
Common mode rejection	Min.: 74 dB, typical: 90 dB
Controls	Level control $\pm$ 6 dB, bypass switch for the active filters (for operations with K&F System Controller), ground lift switch
Display	Bi-coloured LED: green = Power On, red = Limit / Protect
Driver circuit	Peak limiter, RMS limiter High-pass 45 Hz (-3 dB), 24 dB / octave ('FILTERS ON'), Phase correction, frequency equalisation (EQ)
<b>Amplifier module (2 x)</b>	
Type	Class D
Power	1000 W @ 8 $\Omega$ ( EIAJ / 1 kHz, 1% THD)
Power bandwidth	10 Hz to 30 kHz
Damping factor	> 500 (100 Hz), > 100 (10 kHz)
S / N ratio	> 105 dB (A)
Cooling	Air convection (without fan)
Protection circuits	Short circuit, over-temperature, clipping, overload
<b>Enclosure</b>	
	Trapezoidal, frame-reinforced 15 mm birch plywood with with highly resistable grey or black structured paint, 2 butterfly handles, ball proof front grille with exchangeable black acoustic foam
Rigging	4 flying points 'allsafe JUNGFALK' 1 rear mounted flying track 'allsafe JUNGFALK'
Dimensions	429 x 1025 x 510 mm (W x H x D)
Weight	57.5 kg
Options	special finish in RAL colours

Technical changes without prior notice reserved



## 16. Measuring Charts

### 16.1 LINE 212-6 - SP

Frequency response 'on axis'

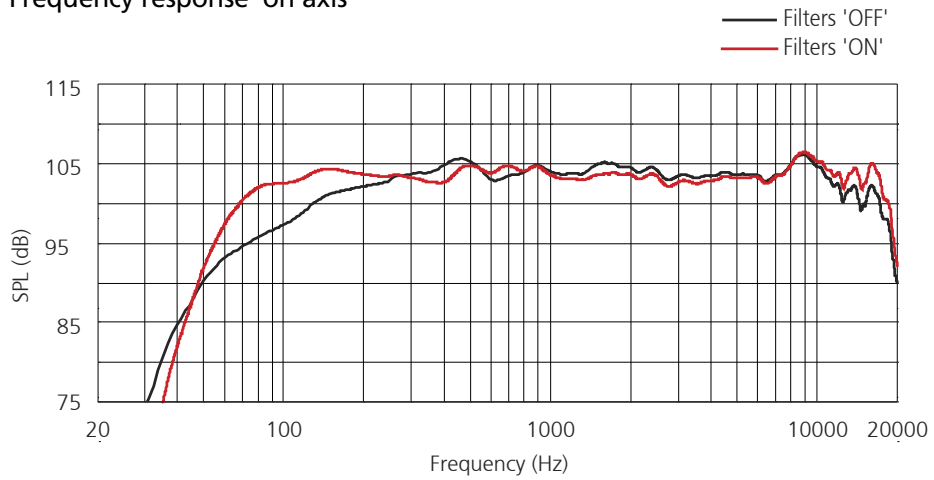

Beamwidth

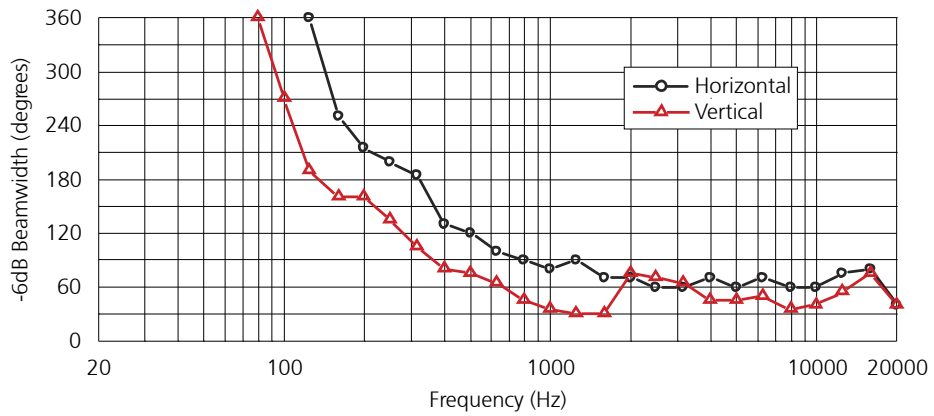

Q-Index

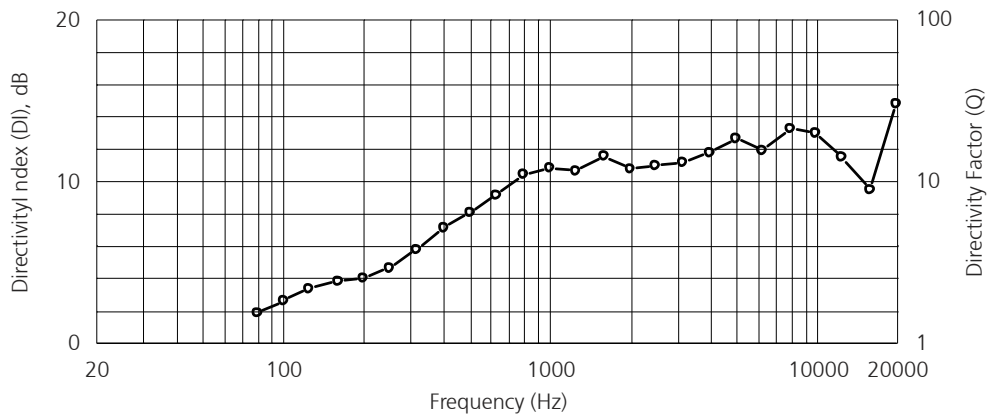

### Horizontal coverage pattern

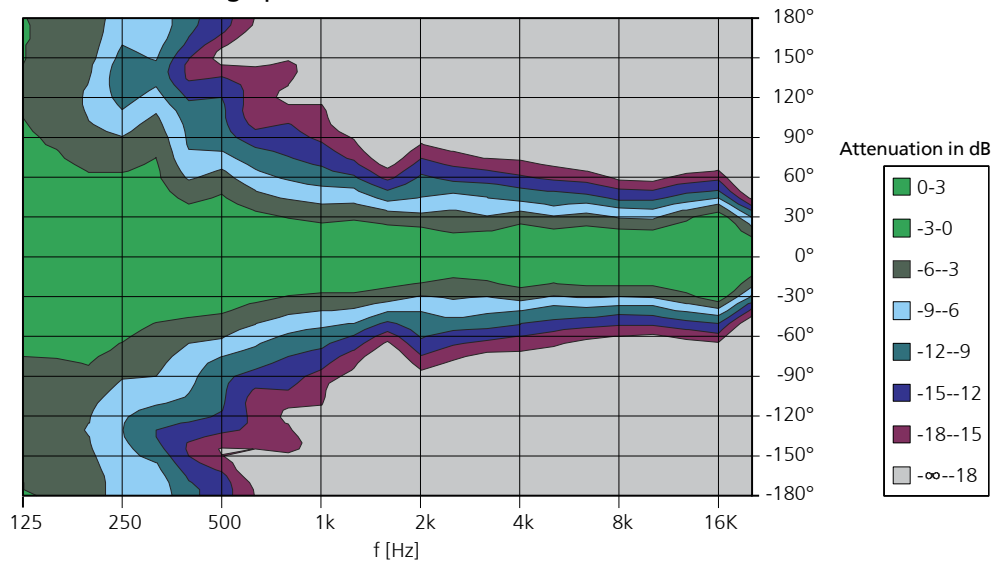

### Vertical coverage pattern

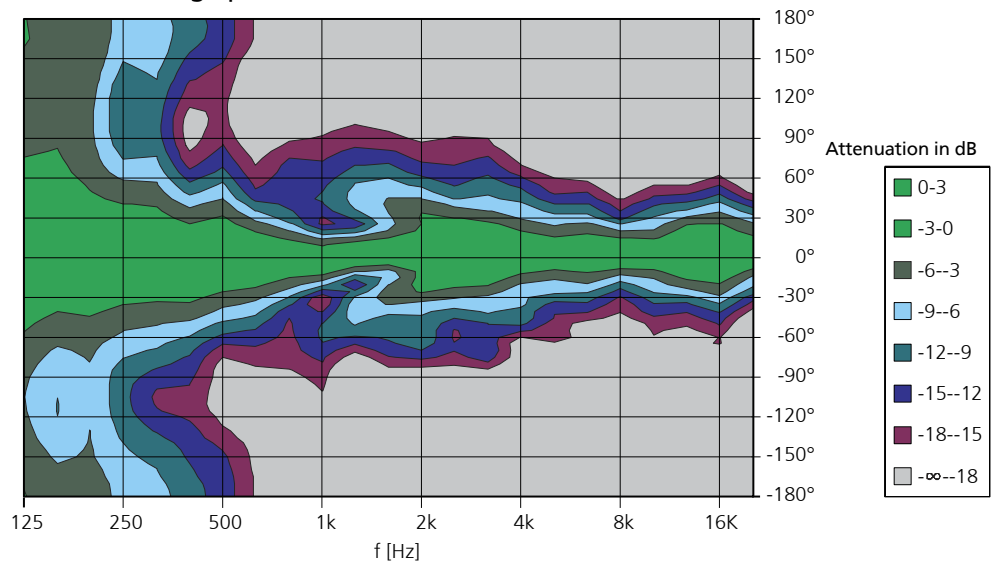

### 16.2 LINE 212-9 - SP

Frequency response 'on axis'

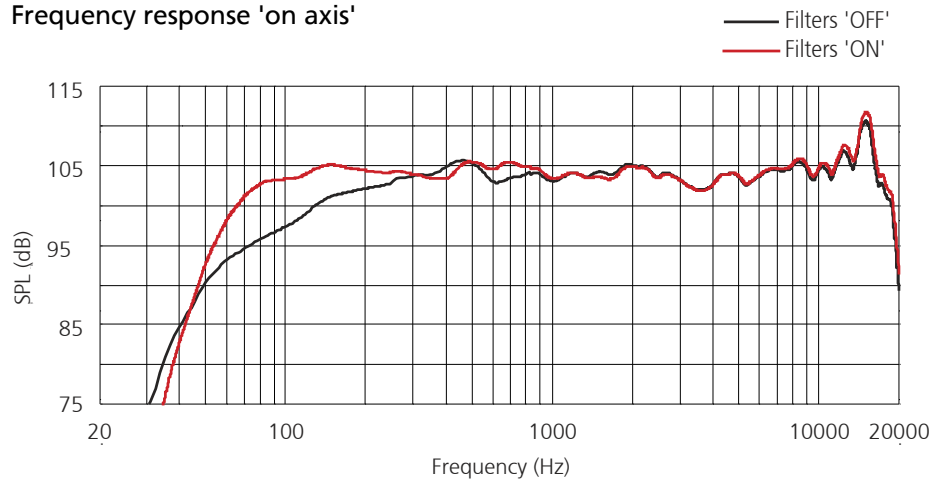

Beamwidth

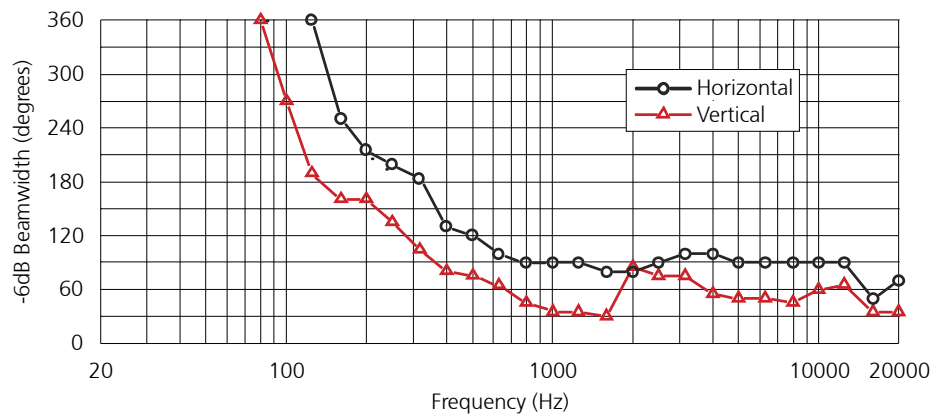

Q-Index

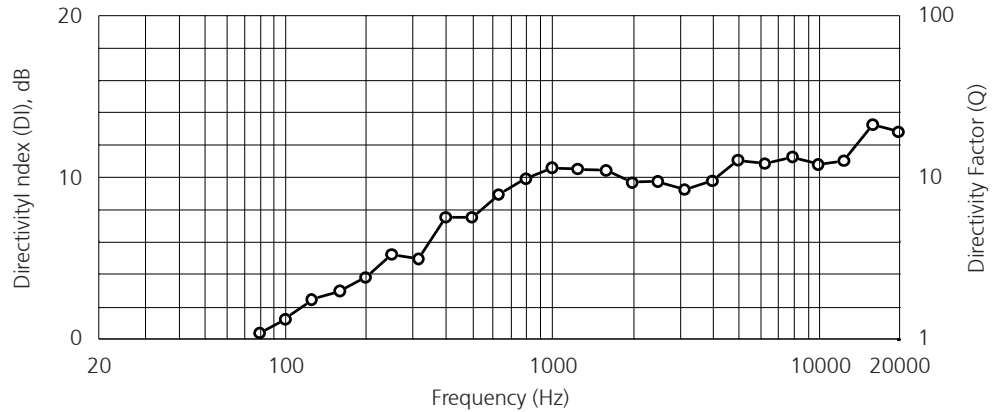

### Horizontal coverage pattern

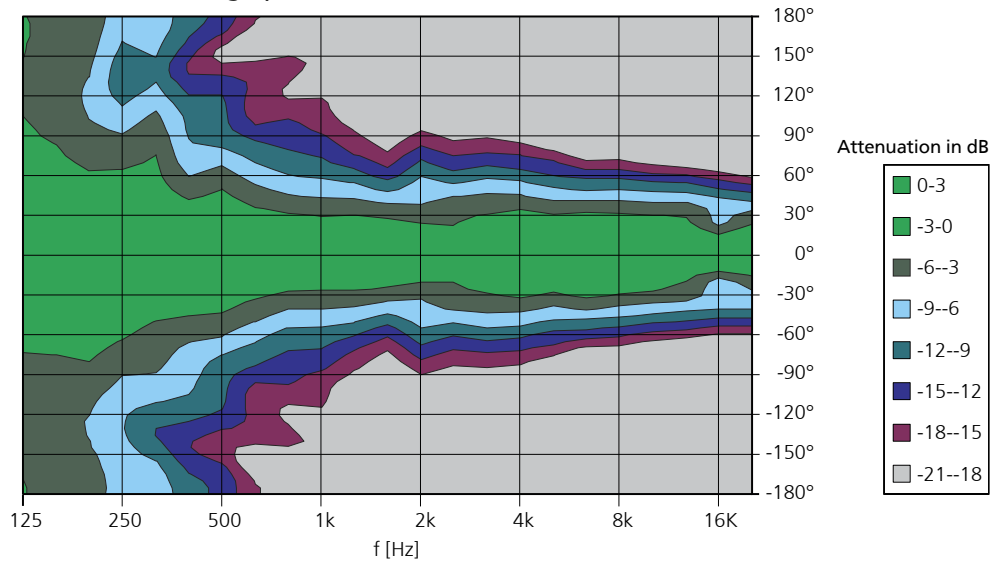

### Vertical coverage pattern

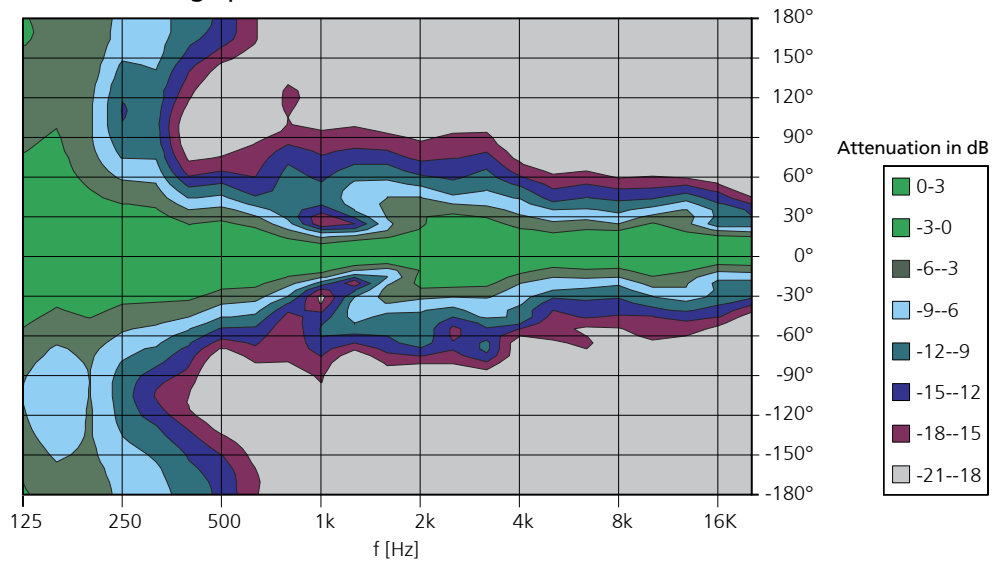

**17. Dimensions**

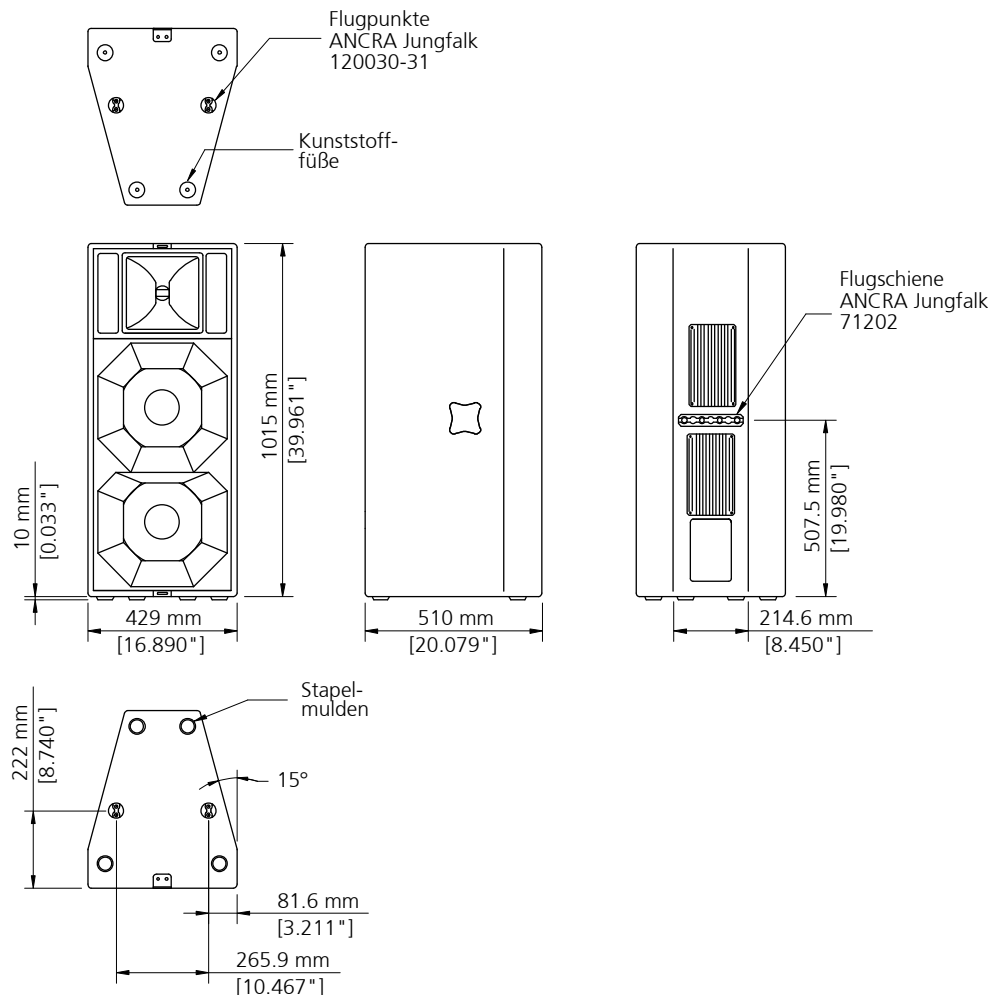

### 18. Accessories for the LINE 212 System

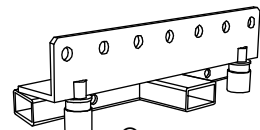

Click & Fly®

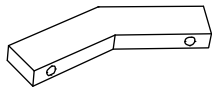

Connector 30°

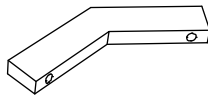

Connector 38.5°

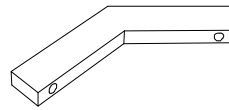

Connector 45°



Quick Release Pin

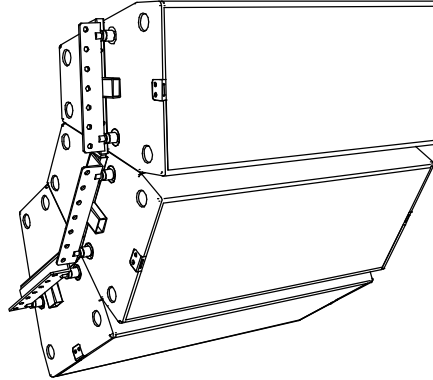
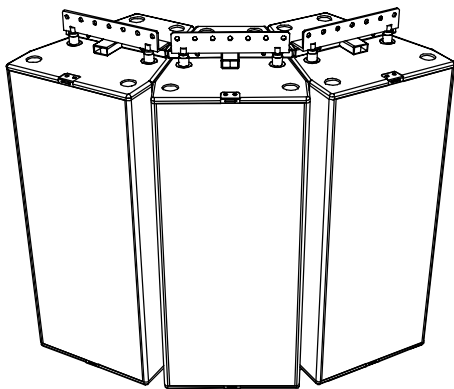

Application examples Click & Fly® LINE 212

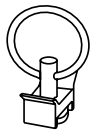

Single Stud Fitting

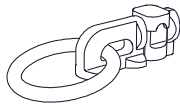

Double Stud Fitting

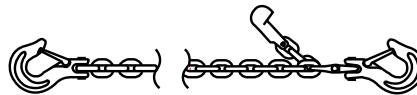

Rigging chain, adjustable (left / right)

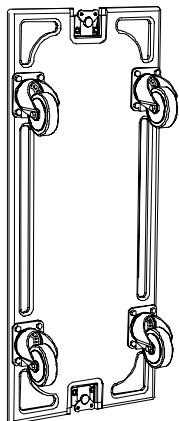

Transport cover with castors

## 19. Regulations for Disposal

### 19.1 Germany

**It is not allowed to dispose of used electrical equipment as domestic waste.**

But please do not dispose of them at official collecting points for recycling either!

All Kling & Freitag products are plain business-to-business (B2B) products. Disposal of Kling & Freitag products labelled with a waste bin sign have thus to be disposed of by Kling & Freitag alone. Please call Kling & Freitag at the number stated below if you have a Kling & Freitag product to be disposed. We will offer you a straightforward and professional disposal not affecting costs.

If there is no dustbin sign on one of your Kling & Freitag products, because they have been sold before March 2006 then by law the owner is in charge of the disposal. For these we will be happy to assist and offer you proper ways of disposal.

**Telephone number to call about the disposal of used Kling & Freitag products:  
+49 (511)-96 99 7-0**

Explanation: With the ElektroG (law relating to electrical and electronic equipment and appliances) we have complied with the EU-directive on waste electrical and electronic equipment (WEEE, 2002/96/EC)

The Kling & Freitag GmbH has thus labelled all products mentioned in the WEEE from 03/24/2006 onwards with a sign with a crossed out waste bin and a white bar below. This sign indicates that the disposal into the domestic waste is prohibited and that the product has been put into circulation at the 03/24/2006 earliest.

The Kling & Freitag GmbH has been legally registered as a manufacturer with the registration office EAR. Our WEEE Registration-Nr. is: DE64110372

For the German Registration office EAR we have accredited that our products are sole B2B products.



### 19.2 EU, Norway, Iceland, and Liechtenstein

**It is not allowed to dispose of used electrical equipment as domestic waste.**

The Kling & Freitag GmbH has thus labelled all products coming from EU-Member countries as well as Norway, Island and Liechtenstein (except Germany) mentioned in the WEEE from 08/13/2005 onwards with a sign with a crossed out waste bin and a white bar below. This sign indicates that the disposal into the domestic waste is prohibited and that the product has been put into circulation at the 08/13/2005 earliest.

Unfortunately the European directive WEEE has been complied with implementing different national provisions of law throughout all member countries, which makes it impossible for us to offer consistent solutions for the disposal throughout Europe.

Responsible for complying with these provisions of law is the local distributor (importer) of each country.

For proper disposition of used products in accordance with these local provisions in the mentioned countries of the European Union (except Germany) please ask your local dealer or the local authorities.



### 19.3 Other Countries

For proper disposition of used products in accordance with local provisions in other countries please ask your local dealer or the local authorities.

## 20. Declaration of Conformity and International Certificates

### 20.1 Declaration of Conformity



### EG-Konformitätserklärung

EMV Richtlinie 89 / 336 / EWG

Niederspannungsrichtlinie: 73 / 23 / EWG

Wir: KLING & FREITAG GMBH  
Junkersstraße 14  
**30179 Hannover**  
**Deutschland**

erklären eigenverantwortlich, dass folgende Produkte:

**Art:** Lautsprecher mit integrierten Endverstärkern

**Modelle:** CA 1001 - SP,  
CA 1201 - SP,  
CA 1215-6 - SP, CA 1215-9 - SP,  
CA 1515-6 - SP, CA 1515-9 - SP,  
LINE 212-6 - SP, LINE 212-9 - SP,  
SW 112 - SP, SWi 112 - SP,  
SW 115D - SP, SWi 115D - SP,  
SW 115E - SP, SWi 115E - SP,  
SW 118E - SP, SWi 118E - SP,  
SW 215E - SP

den Anforderungen folgender Normen und Dokumente entsprechen:

EN 60065:1998;  
E9 05 05 50454 004

Hannover, 23.03.2006  
Ort, Datum

Jürgen Freitag  
Geschäftsführer

**Akkreditiertes Prüflaboratorium:** MIKES BABT PRODUCT SERVICE GmbH, Ohmstraße 2-4  
D-94342 Strasskirchen

KLING & FREITAG GmbH  
Innovative Sound Systems

Mitglied folgender Verbände



Ust.-IdNr.: DE 115648828 · Amtsgericht Hannover: HRB 52497  
Geschäftsführer: Martin Kling, Jürgen Freitag  
Stadtsparkasse Hannover: BLZ 250 501 80 · Konto 794 996  
Deutsche Bank 24 Hannover: BLZ 250 700 24 · Konto 4410601

Junkersstraße 14 · D-30179 Hannover  
Phone: 0(049) 511 96 99 7-0  
Fax: 0(049) 511 67 37 94  
info@kling-freitag.de · www.kling-freitag.de



## 20.2 EMV Certificate Directive 89 / 336 / EWG

ZERTIFIKAT • CERTIFICATE • 認証証書 • CERTIFICADO • CERTIFICAT							
	<h2>EC-Certificate of Conformity</h2> <p>No. E9 05 05 50454 004</p>						
	<b>Holder of Certificate:</b> <b>Kling &amp; Freitag GmbH</b> Junkersstr. 14 30179 Hannover GERMANY						
	<b>Name of Object:</b> <b>Loudspeakers with or without built-in amplifiers</b> <b>Act. full-range loudspeaker system w. int. amplifier(s)</b>						
	<b>Model(s):</b> <b>LINE 212-6 SP and CA1515-6 SP</b> <b>Multilisting-models:</b> <b>CA 1001-SP; CA 1201-SP; CA 1215-6-SP;</b> <b>CA 1215-9-SP; CA 1515-9-SP;</b> <b>Line 212-9-SP;</b> <b>SW 112-SP; SWi 112-SP;</b> <b>SW 115D-SP; SWi 115D-SP;</b> <b>SW 115E-SP; SWi 115E-SP;</b> <b>SW 118E-SP; SWi 118E-SP;</b> <b>SW 215E-SP;</b>						
	<b>Description of Object:</b> <table border="0" style="margin-left: 20px;"> <tr> <td>Rated voltage:</td> <td>115V, 230V</td> </tr> <tr> <td>Rated input power:</td> <td>300W, 500W</td> </tr> <tr> <td>Protection class:</td> <td>I</td> </tr> </table>	Rated voltage:	115V, 230V	Rated input power:	300W, 500W	Protection class:	I
	Rated voltage:	115V, 230V					
	Rated input power:	300W, 500W					
	Protection class:	I					
	<p>This EC-Certificate of Conformity is issued according to Article 10.2 of the Council Directive 89/336/EEC on the harmonization of the laws of the Member States relating to electromagnetic compatibility. It was transposed into the "Gesetz über die elektromagnetische Verträglichkeit von Geräten vom 18. September 1998 (EMVG, § 4 (2))". This Certificate does not contain any statement pertaining to the EMC protection requirements governed by other laws to implement EC Directives other than the aforementioned Council Directive 89/336/EEC. See also notes overleaf.</p>						
<b>Test report no.:</b> E25079RM							
<b>Eduard Stangl</b> Stv. des Leiters der zuständigen Stelle Date, 2005-05-18							

TÜV Product Service GmbH is Competent Body in accordance with EMC Directive 89/336/EEC (BMPT VFG. 91/1992).

Page 1 of 1

**TÜV PRODUCT SERVICE GMBH • Zertifizierstelle • Ridlerstrasse 65 • D-80339 München**  
**Gruppe TÜV Süddeutschland**

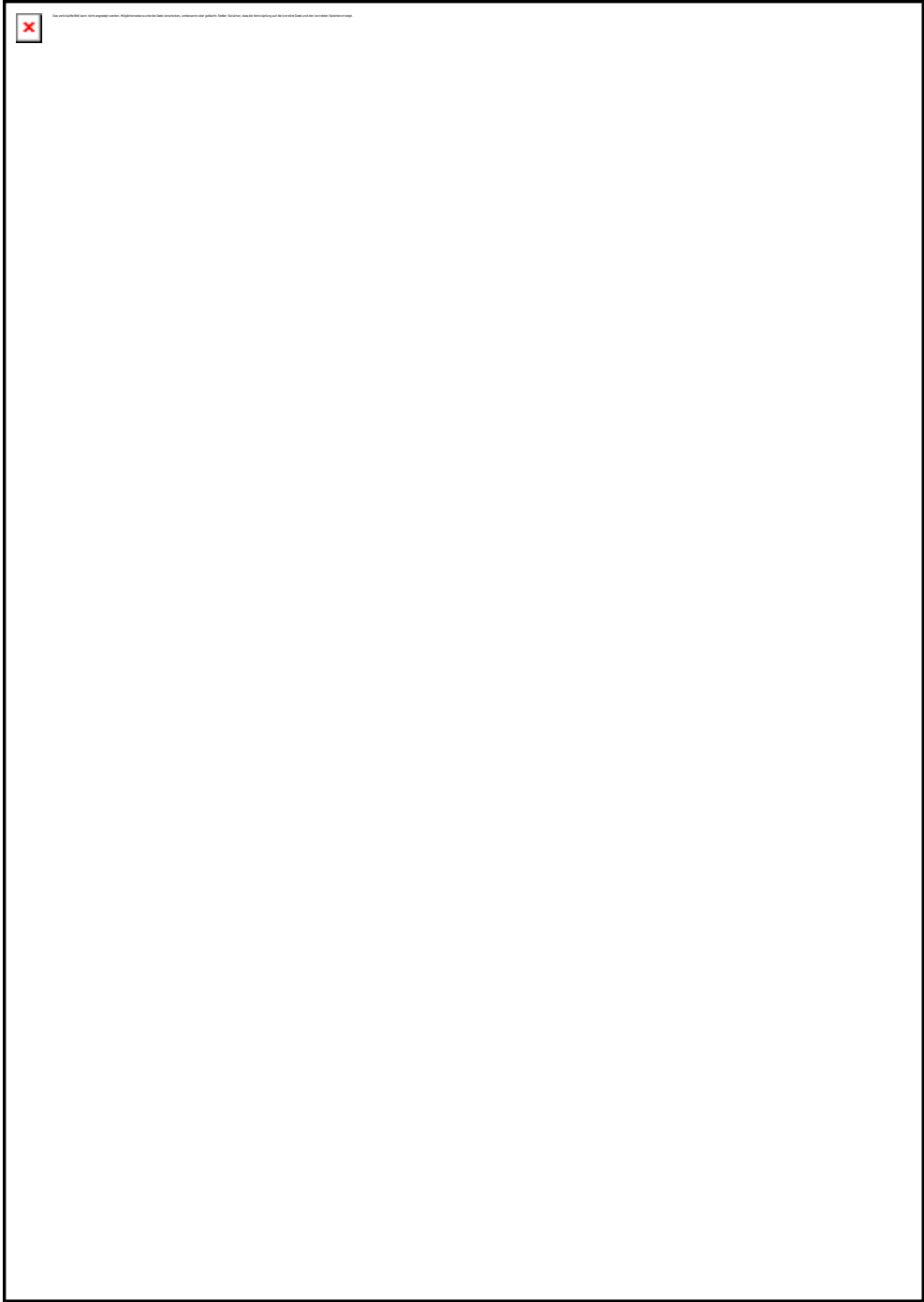

### 20.3 TÜV Certificate for USA und Canada (UL 6500)

**ZERTIFIKAT • CERTIFICATE • 認証証書 • СЕРТИФИКАТ • CERTIFICADO • CERTIFICAT**

  
America

# CERTIFICATE

No. U8 05 06 50454 005

**Holder of Certificate:** **Kling & Freitag GmbH**  
Junkersstr. 14  
30179 Hannover  
GERMANY

**Certification Mark:** 

**Product:** **Audio appliances**

The product was voluntarily tested according to the relevant safety requirements and mentioned properties. It can be marked with the certification mark shown above. See also notes overleaf.

**Test report no.:** 067-25976-000

**Date,** 2005-06-03  
Page 1 of 2





TÜV AMERICA INC. • TÜV SÜD Group • Certification Body • 5 Cherry Hill Drive • Danvers MA 01923 USA

**CERTIFICATE**

No. U8 05 06 50454 005

**Model(s):** LINE 212-6-SP; LINE 212-9-SP;  
 CA 1001-SP; CA 1201-SP;  
 CA 1215-6-SP; CA 1215-9-SP;  
 CA 1515-6-SP; CA 1515-9-SP;  
 SW 112-SP; SWi 112-SP;  
 SW 115D-SP; SWi 115D-SP;  
 SW 115E-SP; SW 118E-SP;  
 SWi 118E-SP; SW 215E-SP

**Brand Name:** Kling & Freitag Systems

**Parameters:**

Rated voltage:	115 V
Rated frequency:	60 Hz
Rated power:	2000 VA max.
Protection class:	I

**Tested according to:** UL 6500:1999  
 CAN/CSA-E 60065:1999

**Production Facility(ies):** 50454

Page 2 of 2

TÜV AMERICA INC. • TÜV SÜD Group • Certification Body • 5 Cherry Hill Drive • Danvers MA 01923 USA